

# builder's mate



## WINDOW REVEAL DETAILS

Most aluminium windows are secured within the rough opening by fixing through the timber reveals into the framing, so getting the fixing right is obviously important. Get it wrong, and a building could potentially face problems if the window is not adequately secured against wind suction, or there could be risks to weathertightness.

Reveals – sometimes called liners – are the visible timber surrounds of an aluminium door or window. They are required to have a durability of 15 years minimum (but obviously building owners will expect a far longer lifespan). Reveals are often finger-jointed pine treated to a minimum of H3.1, but heart rimu and other timbers are given in NZS 3602:2003 *Timber and wood-based products for use in building*. Moisture content must be 18% or less at the time of installation. Materials other than timber may also be

used. Whatever material is chosen must be specified in building consent applications.

### Fitting tolerances

Typically, an installed window should have an 8–10 mm gap between the back of the reveal and the framing trimming the opening. This tolerance allows the window to be fitted into the opening and trued as well as giving sufficient space for the air seal. >



worth \$119!

WIN!

A drill bit sharpener



0800 948 665  
www.thetoolshed.co.nz

## INDUSTRY NEWS

### New workplace safety law

The new Health and Safety at Work Act is now law. It comes into force on 4 April 2016 – until then, the Health and Safety in Employment Act 1992 still applies.

Regulations are being developed to cover risk and workplace management, asbestos, major hazard facilities and worker participation.

### Changes in earthquake strengthening

Certain types of buildings will soon need earthquake strengthening in half the time previously required. They include those with unreinforced masonry features that could fall onto a footpath or road. About 2,000 buildings are likely to be involved. The rule will apply to medium and high-risk areas and is likely to become law before the year's end.

### New editions of BRANZ books

Two new editions of popular BRANZ books are available: a 2nd edition of the Good Practice Guide *Profiled Metal Wall Claddings* and a 3rd edition of the Good Practice Guide *Timber Cladding*.

## HAMMER 'N' NAILS



## Fixing a window reveal

There are two common methods of fixing the reveals to the building structure:

- Nailing through the reveal into the building structure (Figure 1). This method is described in Acceptable Solution E2/AS1 and in installation details developed by the Window Association of New Zealand (WANZ).
- Using hidden installation brackets. This would require building consent as an alternative method.

## Installing air seals

Around doors and windows, an air seal – typically polyurethane foam – over a backing rod must be installed at the inner face of the framed opening. This creates a complete seal between the framed opening and the window or door reveal, which works in conjunction with the plasterboard interior lining to form an air barrier. This closes off air leaks to the interior and moderates the air pressure difference between the trim and frame cavity and the exterior. Allowing air pressures to equalise reduces the risk of airflows caused by pressure differences carrying water into the wall cavity.

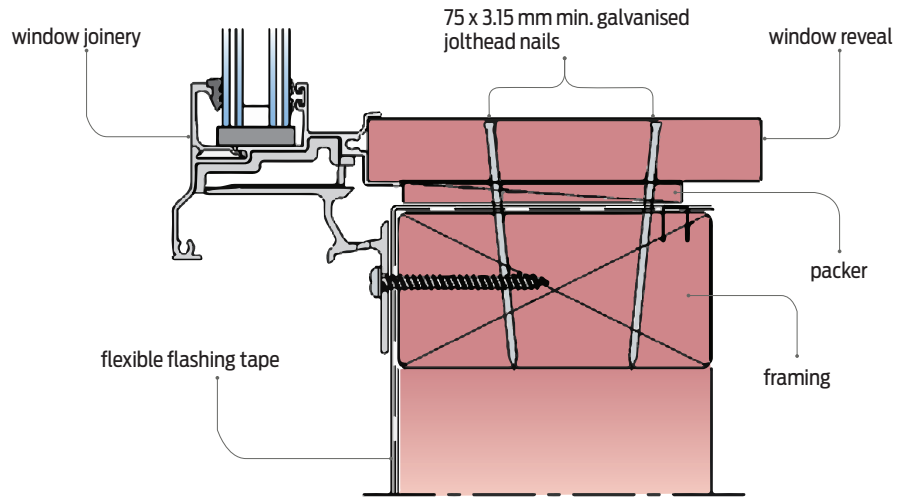

**Figure 1: Fixing a window reveal**

Figure 1 is based on Detail 12 from the WANZ Guide to Window Installation. Reproduced with permission.

Packers for the window need to be installed so that they will allow a continuous bead of air seal around the perimeter of the reveals. (The backing rod can be fitted between packers.)

E2/AS1 calls for packers at all fixing points between reveals and framing except between head reveals and lintels.

The WANZ window installation instructions specify that the packers must be flat – not wedges. They also suggest inserting packers at the head of the unit

but removing them after fixing to allow any potential settlement of the building structure.

E2/AS1's specific fixing instructions require pairs of minimum 75 x 3.15 mm galvanised jolthead nails or 8 gauge x 65 mm stainless steel screws through reveals into surrounding framing at:

- maximum 450 mm centres along sills, jambs and heads
- maximum 150 mm from reveal ends.



# Mouthpiece

## Being held to account

It is too easy to walk onto a number of building sites today without being challenged. Often, no one seems to be in charge. Ask workers a question, and a common answer is 'I am only here to ...' or 'That is not my responsibility.'

These experiences beg the question: Who is accountable?

There has been a lot of media coverage about building defects and BCA inspection fail rates. Some leaky buildings are undergoing a second round of repairs. BRANZ surveys show a widening gap between industry performance and client expectations and too many defects in new homes.

Years ago, building sites had a clerk of works or an overseer to ensure quality building work. Today, separate contractors form the slab, erect the frames and so on. Designers are often not employed to observe construction. Time is always tight.

We need to bring pride back into the industry. The right attitude is key, but we also need to:

- keep clients informed and keep open lines of communication with the designer, subtrades and the BCA
- get adequate construction drawings/specifications and keep them on site
- say no to poor-quality work
- employ staff with sufficient skills
- meet start and finish dates
- make one person responsible for delivering the building to the specified standard and timely follow-up.

Our image has taken a hammering, and we need to restore confidence in our industry.

As NZIA President Pip Cheshire said, 'It is time that we, the building industry, showed confidence and a commitment to ensuring the products of our labours are the best that science, industry and creative endeavour can deliver.'

# Fixing edge distances for **bottom plate anchors** on concrete slabs

Anchors that fix the bottom plate to the concrete floor slab play a critical role in securing the framed structure of the building to the foundation. They have to withstand uplift forces as well as shear forces along and across the wall.

Getting the fixing dimensions right is crucial. BRANZ testing has shown that, if the edge distances are wrong, the anchors can fail.

Unfortunately, a survey of new homes under construction has found edge distance requirements aren't always being met.

NZS 3604:2011 *Timber-framed buildings* (section 7) shows the requirements for cast-in anchors and proprietary (post-fixed) anchors.

**Cast-in anchors** are M12 bolts (with 50 x 50 x 3 mm washers), bent to prevent turning. They are set no more than 150 mm from each end of the plate at maximum 1200 mm centres (Figure 2). With an in-situ concrete slab edge, anchors must be embedded at least 90 mm into the slab or at least 120 mm with concrete masonry header blocks at the slab edge.

Cast-in anchors must be fixed **at least 50 mm from the edge of the slab.**

There is a potential issue if a 90 mm bottom plate is used and the anchors are fixed in the centre of the bottom plate. The distance between anchors and the slab edge may be insufficient to withstand the forces on the wall framing.

**Proprietary anchors** are inserted into the slab after the concrete has cured, no more than 150 mm from each end of the plate. They must be installed at maximum 900 mm centres where the slab edge is in-situ concrete and 600 mm where the slab edge is formed with concrete masonry header blocks.

NZS 3604:2011 doesn't show edge distance measurements for proprietary bottom plate anchors because there are different styles and types available. For proprietary anchors, follow the manufacturer's instructions carefully.

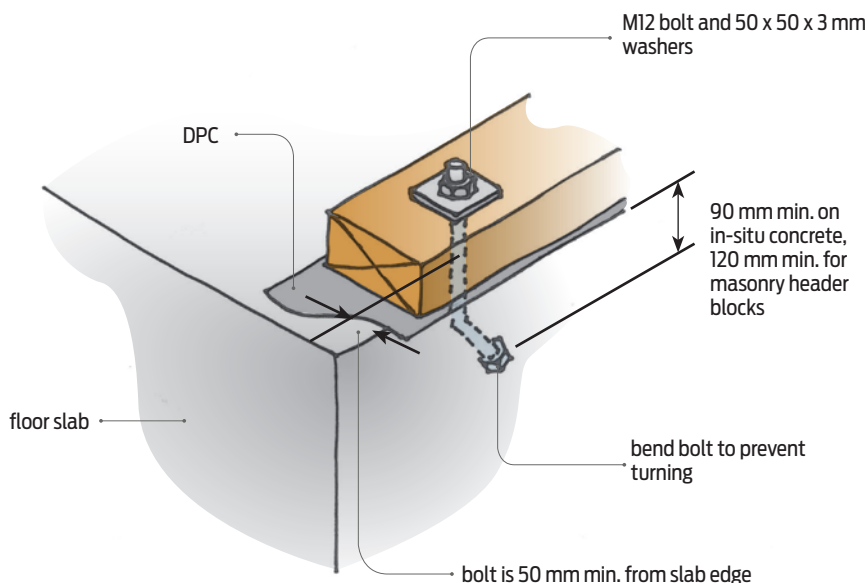

Figure 2: Bottom plate fixing

# build

“Do you get your free Build magazine?”



All building contractors who are in the business of building and have paid a Building Research Levy in the current year can receive BRANZ's *Build* magazine for free. This Levy is paid as part of the building consent fee on all construction projects over \$20,000. If you are missing out on your free copy of *Build*, call 0800 80 80 85 (press 2) or email [vera.chan@branz.co.nz](mailto:vera.chan@branz.co.nz).

**Build now free online**

[www.buildmagazine.org.nz](http://www.buildmagazine.org.nz)



## ADVISORY HELPLINES

For the building and construction industry:

**0800 80 80 85**

For the homeowner and public enquiries:

**0900 5 90 90**

Calls cost \$1.99 per minute plus GST

[WWW.BRANZ.CO.NZ](http://WWW.BRANZ.CO.NZ)

# Competition

Here's a tool



What is it?

**Win!**

A drill bit sharpener



worth \$119!

This electric drill bit sharpener is fast, easy and efficient to keep your HSS drill bits sharp and ready to go. Takes bits 3–13 mm. This sharpener uses a specially set diamond grind wheel for long life and more precise sharpening.

The prize is provided courtesy of The ToolShed.

All you need to do to win is tell us the name of the mystery tool (above).

Email your answer to [buildersmate@branz.co.nz](mailto:buildersmate@branz.co.nz). Put "October Competition" in the subject line. The message should include your answer, your name, postal address and phone number. One entry per entrant please.

Don't forget to tell us where you picked up your copy of *Builder's Mate*! The winner will be the first correct entry drawn at 9 am on Friday 13 November 2015. Details will be posted on the BRANZ Ltd website ([www.branz.co.nz](http://www.branz.co.nz)) and in the next edition of *Builder's Mate* due out on 1 December 2015.



There were three winners of the August *Builder's Mate* competition: Brendon Ray from Hastings, Marty Parker from Johnsonville, Wellington, and Shane Mcinteer from Kaiwaka. Each of them wins a multifunction tool worth \$79.95. The mystery tool was a variable step drill bit.

#### Terms and conditions:

Entry is open to all New Zealand residents except employees and immediate families of BRANZ and The ToolShed shops. The competition will close at 9 am on Friday 13 November 2015. The prize is not transferable for cash. The judge's decision is final. No correspondence will be entered into.

## + BUILDERS' APPS

In this series, we'll introduce some great apps and tools for your smartphone. The apps can be found in the iPhone store and/or the Android store. If you know any you'd like to recommend, email us the details at [buildersmate@branz.co.nz](mailto:buildersmate@branz.co.nz).



#### RECEIPT BANK

Take a photo of receipts or invoices, and the app extracts key data. You can view it, edit it and create reports. Free trial available.

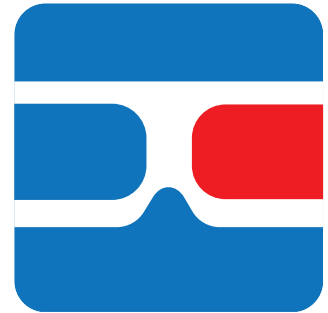

#### GOOGLE GOGGLES

Take a photo of a famous landmark, a product and so on, and the app searches Google to find information about it.



## Welcome to BRANZ Find

Enter Search

 SEARCH

The BRANZ Find digital helpline is a useful, comprehensive directory of New Zealand building and construction industry information.

BRANZ Find provides free online access to building information and the documents commonly requested from the BRANZ 0800 advisory service.

Use it to search and find links to resources including study reports, online tools, guidelines, Codes of Practice, technical guidance, the Building Code, standards and legislation.

[www.branzfind.nz](http://www.branzfind.nz) or call 0800 80 80 85

Although BRANZ has made every attempt to ensure the accuracy of its information, it provides generic advice only, and BRANZ accepts no liability for any loss or damage incurred. Opinions expressed in *Builder's Mate* do not necessarily reflect the views of BRANZ.

Standards referred to can be purchased from Standards New Zealand. Tel: 04 498 5991 or [www.standards.co.nz](http://www.standards.co.nz).

©BRANZ Ltd, October 2015.

[www.branz.co.nz](http://www.branz.co.nz)