



# STUDY REPORT

No. 162 (2007)

## **Maximum Wall Bracing Rating that is compatible with NZ 3604 Construction**

**Phase I: Theory, Summary and Bracing Testing of Single Walls on a  
Timber Piled Foundation**

**SJ Thurston**



The work reported here was funded by Building Research Levy.

© BRANZ 2007

ISSN: 0113-3675

## Preface

This is the first of three BRANZ reports on the investigation of the maximum racking load a bracing wall can carry which is compatible with the strength of the minimum construction stipulated by NZS 3604. It is referred to as Phase I and considers:

- (a) transferring horizontal earthquake and wind load into the wall; and
- (b) transferring both horizontal and racking-induced vertical load from the wall into the foundation.

In this phase a series of isolated bracing walls was constructed on top of a large floor and foundation. The bracing loads at which failure of the connection between floor members, such as blocking-to-joists, joists-to-bearers, and bearers-to-piles and the wall bracing load at which uplift of piles occurred, was measured. The low values so determined were of concern. This stimulated the research in BRANZ *Study Report 163* (Phase II of this project), where a single storey building founded on piles, with a ceiling but no roof, was racked to enable 'systems effects' to enhance the performance – as is likely to occur in a real building. It was expected that 'systems effects' would enable higher racking loads to be applied before foundation failure occurred. This work is summarised in Phase II.

Concern was also expressed about the ability of NZS 3604 type buildings to transfer the vertical loads between top and bottom storeys of two storey buildings which are induced by wall racking. That report (BRANZ *Study Report 164* – Phase III of the project) presents test results on a two storey building, with a ceiling but no roof, performed to investigate the strength of this load path.

The maximum bracing established from Phase I tests was modified to account for the end continuity rocking resistance determined in Phase II and Phase III testing. It includes the theoretical calculations of bracing load at which many potential failures could occur. It also provides the final recommendations from all test phases.

## Acknowledgments

This work was funded by the Building Research Levy. Winstone Wallboards Ltd, Auckland, New Zealand donated the wall linings used in the testing described herein.

## Note

This report is intended for standards committees, structural engineers, architects, designers and others researching this topic.

# Maximum Wall Bracing Rating That is Compatible with NZS 3604 Construction

## Phase I: Theory, Summary and Bracing Testing of Single Walls on a Timber Piled Foundation

BRANZ Study Report SR 162(2007)

SJ Thurston

### REFERENCE

Thurston SJ. 2007. 'Maximum Wall Bracing That is Compatible with NZS 3604 Construction. Phase I – Theory, Summary and Bracing Testing of Single Walls on a Timber Piled Foundation'. BRANZ *Study Report 162(2007)*. BRANZ Ltd, Judgeford, New Zealand.

### ABSTRACT

The New Zealand standard used for non-specific design of houses specifies that wall bracing ratings for bracing elements are determined using the BRANZ P21 test method. This prescribes the test procedure under which isolated walls are racked and how the results are used to evaluate the wall bracing ratings. Building designers then ensure that the sum of the earthquake or wind bracing demand, as stipulated in the standard, does not exceed the sum of the bracing resistances of house walls. To do this they use manufacturers' published data giving wall bracing strengths.

The P21 test measures the ability of a wall to transmit a racking load from a wall top plate to its bottom plate. The bracing ratings derived implicitly assume that the load can transfer into the top plate and subsequently be carried from the bottom plate to the ground. By using theory and test results, this report attempts to determine a suitable upper limit wall bracing strength to ensure these assumptions are met. It calls on: Phase II of this project (BRANZ *Study Report 163*) for test results on a large room for load transfer from a single storey superstructure to a piled foundation below; and Phase III of this project (BRANZ *Study Report 164*) for test results on a large room for load transfer between upper and lower floors with typical NZS 3604 New Zealand house construction.

### Keywords

Timber walls, earthquake, seismic, wind, racking, experimental, houses, maximum bracing.

<b>Contents</b>	<b>Page</b>
<b>1. INTRODUCTION .....</b>	<b>1</b>
<b>2. REPORT OUTLINE.....</b>	<b>1</b>
<b>3. THE BRANZ P21 TEST AND EVALUATION PROCEDURE.....</b>	<b>2</b>
3.1 History of the P21 test.....	2
3.2 'Supplementary' uplift restraints.....	3
3.3 'Systems effects' .....	4
3.4 Comparison of the foundation details used in a P21 test and those used in actual construction .....	5
<b>4. USE OF STATISTICS IN DERIVATION OF DESIGN STRENGTHS AND DESIGN PHILOSOPHY .....</b>	<b>7</b>
<b>5. APPLICATION OF BRACING RATINGS.....</b>	<b>8</b>
5.1 Publishing requirements.....	8
5.2 Specific design.....	8
<b>6. BRACING WALL END REACTIONS.....</b>	<b>9</b>
6.1 Introduction .....	9
6.2 Calculation of bracing wall end anchor forces and end reactions .....	9
6.3 Wall end reaction tables.....	11
<b>7. GETTING THE LOAD INTO A BRACING WALL.....</b>	<b>14</b>
7.1 Introduction .....	14
7.2 Transmission via top plate.....	15
7.3 Transmission via ceiling-to-bracing wall.....	16
7.4 Transmission via both mechanisms .....	16
<b>8. MAXIMUM BRACING RATING FOR WALLS ON CONCRETE FOUNDATIONS .....</b>	<b>16</b>
8.1 Background.....	16
8.2 Exterior walls .....	16
8.3 Interior walls .....	19
8.4 Failure of concrete foundations in flexure.....	19
<b>9. MAXIMUM WALL BRACING RATING BEFORE FAILURE OF BOTTOM TIMBER PLATE.....</b>	<b>20</b>
9.1 Background.....	20
9.2 Bottom plate flexural strength.....	20
9.3 Bracing load at which the timber plate flexural strength is exceeded .....	20
<b>10. MAXIMUM WALL BRACING RATING TO CAUSE BEARER OR JOIST FAILURE .....</b>	<b>21</b>
10.1 Introduction .....	21
10.2 Determination of loads transmitted to bearers and joists from bracing walls .....	22

10.3	Maximum bracing rating to cause joist failure .....	22
10.3.1	Exterior double joists .....	23
10.3.2	Interior single joists .....	25
10.4	Maximum bracing rating to cause bearer failure .....	25
10.4.1	Wall parallel to bearer.....	25
10.4.2	Wall perpendicular to bearer .....	27
11.	<b>BLOCKING-TO-JOIST CONNECTION .....</b>	<b>27</b>
12.	<b>SEPARATION OF FLOOR MEMBERS AT FIRST FLOOR LEVEL .....</b>	<b>27</b>
13.	<b>SEPARATION OF FLOOR JOISTS FROM PLATES AND BEARERS.....</b>	<b>29</b>
14.	<b>MAXIMUM WALL BRACING RATING FROM FLOOR TESTS.....</b>	<b>30</b>
14.1	Description and purpose of tests .....	30
14.2	Failure loads .....	30
14.2.1	Load parallel to bearers.....	30
14.2.2	Load parallel to joists.....	31
14.3	Modification for end restraints .....	31
15.	<b>RECOMMENDED MAXIMUM WALL BRACING RATING FROM TOTAL PROJECT (PHASE I, II AND III) .....</b>	<b>34</b>
15.1	Earthquake demand loading.....	34
15.2	Considerations used for prescribing a maximum bracing limit.....	35
15.3	Maximum bracing rating for walls founded on timber floors .....	35
15.3.1	Comparison of measured and predicted member strengths .....	35
15.3.2	Recommended maximum bracing loads for minimal changes to NZS 3604 .....	36
15.3.3	Required changes to NZS 3604 for a maximum bracing of 110 BU's/m to be appropriate.....	38
15.3.4	Other conclusions.....	41
15.4	Maximum bracing rating for walls founded on concrete floors.....	42
16.	<b>REFERENCES .....</b>	<b>43</b>

## Figures

Figure 1.	Hysteresis loops from a typical P21 test .....	3
Figure 2.	Components of racking wall deflection and sketch of the BRANZ P21 uplift restraints .....	4
Figure 3.	Restraint of wall lining in real buildings .....	5
Figure 4.	Using bolts to fix a wall to foundation.....	6
Figure 5.	Using straps to fix a wall-to-timber foundations .....	7
Figure 6.	Rocking forces on bracing panel.....	10
Figure 7.	Transfer of sheathing uplift force to bottom plate via bottom plate nails .....	13
Figure 8.	Rotation of bottom plate in a wall sheathed on one side only .....	14
Figure 9.	Transmission of force from top plate into bracing wall .....	15
Figure 10.	Yield line crack pattern in concrete slab.....	20

Figure 11. Flexural loading of bottom plate .....	21
Figure 12. Loading on joists and bearers .....	23
Figure 13. Typical influence line of maximum bearer bending moment .....	26
Figure 14. Cross-section of typical upper floor to lower connection using power-driven nails .....	29
Figure 15. Typical flooring test .....	33
Figure 16. Typical acceleration response spectrum showing increase in response of a house when flexibility increases .....	34
Figure 17. Pre-load of anchor bar and subsequent forces when angle pulled in tension.....	48
Figure 18. Expected plot of measured force and applied force.....	49
Figure 19. Forces in load cell in Test L1 .....	49
Figure 20. Forces in load cell in Test L3 .....	50
Figure 21. Plan of floor test specimen.....	54
Figure 22. Section A-A of floor test specimen .....	55
Figure 23. Section B-B of floor test specimen .....	56
Figure 24. Added floor weights.....	57
Figure 25. Location of test wall.....	58
Figure 26. Test L1 – general view .....	59
Figure 27. Test L1 – uplift at racking force = 7.42 kN push at tension end of wall.....	60
Figure 28. Test L1 – uplift at racking force = 8.42 kN pull at tension end of wall .....	60
Figure 29. Test L1 – close-up of Figure 28 .....	61
Figure 30. Test L1 – uplift at racking force of 8.42 kN pull at compression end of wall .....	61
Figure 31. Test L1 – curvature of Side 1 from uplift of joists from bearer .....	61
Figure 32. Hysteresis loops – Test L1A and L1B.....	62
Figure 33. Hysteresis loops – Test L1C .....	62
Figure 34. Test L2 – uplift of joist from bearer.....	63
Figure 35. Test L2 – crack in joist .....	63
Figure 36. Hysteresis loops – Test L2A .....	64
Figure 37. Hysteresis loops – Test L2B .....	64
Figure 38. Calculation of bending moment at joist flexural failure location .....	65
Figure 39. Hysteresis loops – Test L3.....	65
Figure 40. Test arrangement – Test L3.....	66
Figure 41. Nail pull-out from joist –Test L3.....	66
Figure 42. Deflections along the loaded side of Test L3 .....	66
Figure 43. Hysteresis loops – Test L4.....	67
Figure 44. Test L4 – specimen at peak push load .....	67
Figure 45. Details of plaster joint test specimen.....	68
Figure 46. Photograph of plaster joint test specimen in Dartec test machine .....	69
Figure 47. Lifting of stud from bottom plate.....	71
Figure 48. Lifting of bottom plate from timber floor.....	71
Figure 49. Test set-up used to measure stud/plate tension strength .....	72
Figure 50. Typical relationship between tension load and two-nail stud/plate joint deflection .....	73
Figure 51. Test set-up used to measure bottom plate to timber joist tension strength.....	74
Figure 52. Typical relationship between tension load and single nail plate to foundation beam joint deflection .....	75
Figure 53. Backbone curves to hysteresis loops for a four-nail end restraint joint.....	76

<b>Tables</b>	<b>Page</b>
Table 1. Calculated uplift reaction for combinations of racking load and panel length .....	11
Table 2. Calculated wall downward reaction for combinations of racking load and panel length.....	12
Table 3. Typical anchor strengths and corresponding range of maximum bracing ratings.....	18
Table 4. Maximum bracing rating for exterior (double) floor joists with a 12 mm hole .....	24
Table 5. Maximum bracing rating for exterior (single) floor joists without a 12 mm hole .....	24
Table 6. Maximum bracing rating for wall directly above interior floor joists and parallel to the joist .....	25
Table 7. Maximum bracing rating for wall on blocking between interior floor joists .....	25
Table 8. Maximum wall bracing rating (BU's/m) to exceed bearer theoretical flexural capacity .....	27
Table 9. Maximum bracing rating based on floor tests .....	32
Table 10. Measured and theoretical maximum bracing ratings for walls constructed on timber floors .....	39
Table 11. Test results at Location L1 .....	51
Table 12. Test results at Location L2 .....	52
Table 13. Withdrawal strength (kN) of two-nail plate-to-stud connection.....	73
Table 14. Withdrawal strength of single nail on plate-to-stud connection .....	75

## **APPENDICES**

APPENDIX A. FLOOR TESTS.....	45
APPENDIX B. PLASTERBOARD JOINT TESTS.....	68
APPENDIX C. TENSION STRENGTH OF STUD TO BOTTOM PLATE NAILED JOINT .....	70
APPENDIX D. STRENGTH OF P21 END RESTRAINT .....	76

# 1. INTRODUCTION

The New Zealand standard used for non-specific design of low rise timber framed buildings (NZS 3604, SNZ 1999) specifies that wall bracing ratings, for use with this standard, are determined using the BRANZ P21 test procedure (described in Section 3). This tests isolated walls and evaluates the corresponding wall bracing ratings. Building designers then ensure that the sum of the earthquake or wind bracing demand (as stipulated in NZS 3604) does not exceed the bracing resistance of the sum of the walls actually used in the construction. Wall bracing information for proprietary systems is published by various lining and cladding manufacturers.

The test walls are fabricated the same as used in actual construction. A horizontal load is applied to the wall top plate. The test measures the ability of the wall to transmit this load to a foundation beam. The bracing rating derived implicitly assumes that the load can transfer into the top plate and (having been transmitted to the bottom of the wall), then transfer out of the wall and into the ground. To ensure this full load path is adequate for houses designed to NZS 3604, it has been proposed that an upper limit on bracing rating be specified. This report attempts to determine a suitable upper limit. To achieve this it calls on output from Phase II and III of this project, which are racking tests of a single room and two storey room respectively (Thurston 2007(a) and 2007(b)).

The following potential limitations to the required load transfer are examined in this report. The most critical of these is used to determine the recommended maximum bracing rating:

1. Load transfer limit from the ceiling into the bracing wall.
2. Failure of the mechanical anchors which fix the wall to the foundation. The P21 test uses coach screws or bolts, but these are often replaced with various proprietary fasteners in practice.
3. Failure of floor members, such as joists or bearers in timber floors or concrete slab in concrete floors.
4. Failure of the connection between floor members, such as between blocking and joists, joist and bearers, and bearers and piles.
5. Uplift of piles.

If a wall with a bottom plate mechanical anchor is subjected to high bracing rating the bottom plate sometimes fails in flexure. In the P21 test, if the timber in the critical zone is of high strength with no knots or defects then no such failure may occur in the P21 test. This report analyses the maximum bracing rating at which such a failure is likely.

## 2. REPORT OUTLINE

Sections 3-5 deal with the BRANZ P21 test – its history, the simulation of end restraint, evaluation of test results, and application of bracing ratings. A description of ‘systems effects’ is given.

As the crux of the report is the ability of construction to transmit vertical load emanating from horizontal bracing loads, Section 6 calculates the theoretical bracing wall vertical reactions as a function of wall length and bracing rating.



Section 7 demonstrates that the maximum wall bracing rating is unlikely to be limited by the ability of standard construction to transmit horizontal load into the top plate of a bracing wall.

Section 8 demonstrates that suitable concrete anchors can be obtained so that the maximum wall bracing rating is unlikely to be limited by concrete anchor strength or concrete strength.

Section 9 provides a theoretical analysis to calculate the maximum bracing rating before bottom plate flexural failure occurs for systems which bolt the bottom plate to the foundation.

Section 10 provides a theoretical analysis to calculate the maximum bracing rating before bearer or joist flexural failure occurs for houses founded on timber piles.

Section 11 provides a theoretical analysis to calculate the maximum bracing rating before blocking-to-joist connection failure occurs.

Section 12 provides a theoretical analysis to calculate the maximum bracing rating before separation of the upper top plate-to-lower top plate connection and also top plate-to-stud connection.

Section 13 provides a theoretical analysis to calculate the maximum bracing rating before joist-to-plate or joist-to-bearer connection failure occurs. This does not include boundary joists.

The calculations in Sections 9 to 13 use results from Phase II and III of this project to estimate the magnitude of the bracing wall end continuity vertical movement restraint force, called ER, at the tension end and ER' at the compression end.

Section 14 summarises the maximum bracing ratings before foundation failure occurs, based on the results of isolated bracing wall racking tests on a piled foundation, but modified for ER and ER'. The test results are given in Appendix A.

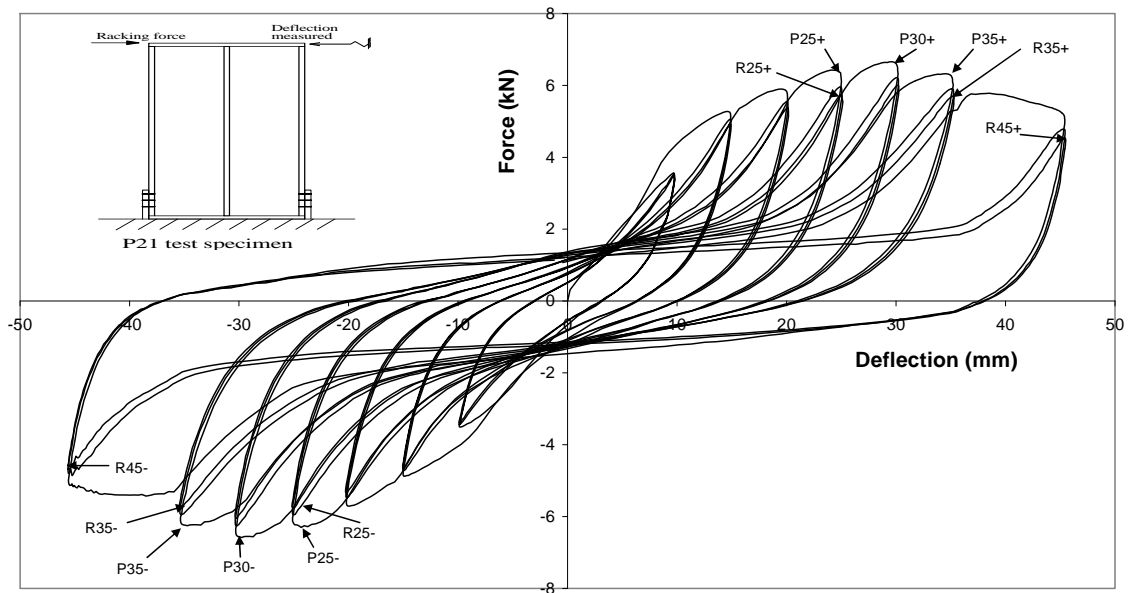
Section 15 summarises the recommended maximum bracing ratings that could be achieved before foundation failure for both timber and concrete floors. This is linked in with proposed modifications to NZS 3604 (SNZ 1999). It calls on the conclusions from Phase II and Phase III of this project. Other general conclusions are also listed.

### **3. THE BRANZ P21 TEST AND EVALUATION PROCEDURE**

#### **3.1 History of the P21 test**

The BRANZ P21 test was based on research at the Forest Research Institute (Collins 1975) and subsequent unpublished testing at BRANZ. The P21 wall bracing test and evaluation procedure was first published by BRANZ in 1979 (Cooney and Collins 1979) and was revised in both 1982 and 1987. This used a working stress type approach where the bracing strength depended on the force resisted when it was cyclically loaded to a serviceability limit deflection. (Further loading ensured that there was adequate reserve strength and ductility for the ultimate loading case.) The BRANZ *Technical Recommendation TR 10* (King and Lim 1991) revised the P21 evaluation method to bring it into line with the 1990 revision of the New Zealand standard NZS 3604 *Timber framed buildings* (SNZ 1990) and the bracing strength was generally dependent on the specimen ductility and maximum forces resisted.

Figure 1 shows typical *hysteresis* loops generated in a P21 test. Such loops are used to determine the wall bracing rating.



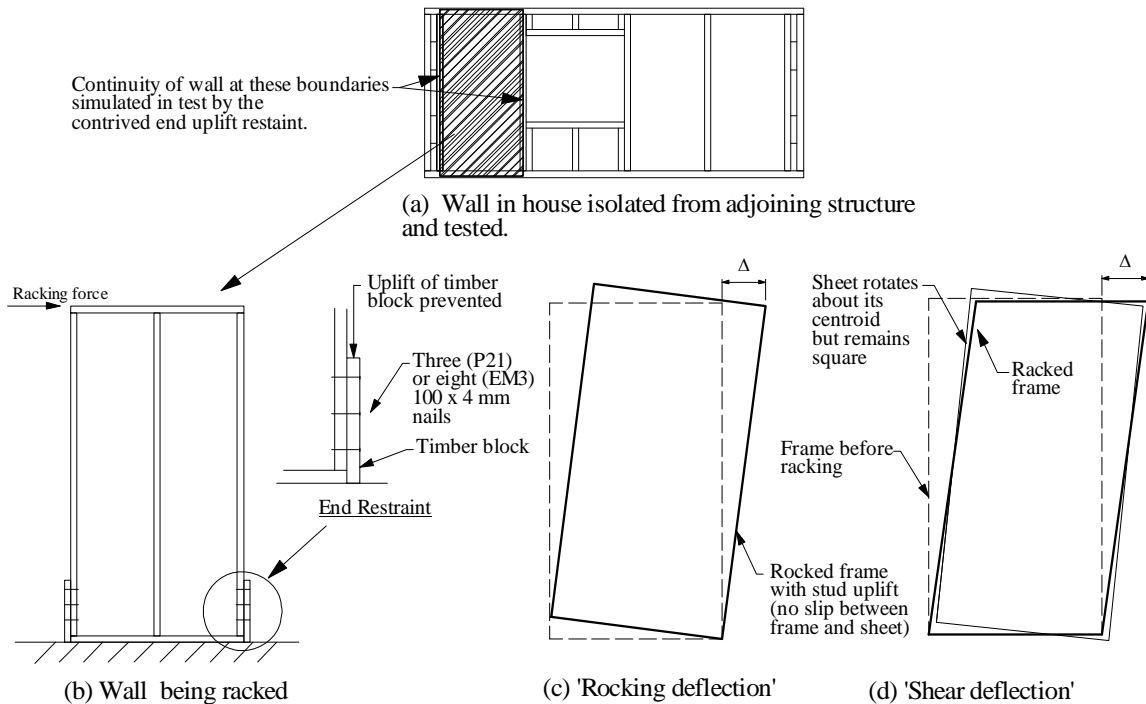
**Figure 1. Hysteresis loops from a typical P21 test**

### 3.2 'Supplementary' uplift restraints

If bracing walls are isolated from the surrounding structure and laboratory tested under horizontal racking loads, without any 'supplementary' end restraints to simulate continuity of actual construction, they would fail at a low racking load unless they included 'special uplift restraints'. This is because the test wall 'rocks' about the bottom compression corner as shown in Figure 2(c).

When bracing panels are built into a house, the continuity of the wall sheathing, framing continuity and gravity effects provide resistance to uplifting, thereby reducing "rocking" effects and increasing the house racking stiffness.

The P21 method uses a 'three-nail' end restraint to simulate the resistance to uplift which exists in real buildings due to the continuity of construction. This is illustrated in Figure 2(b).

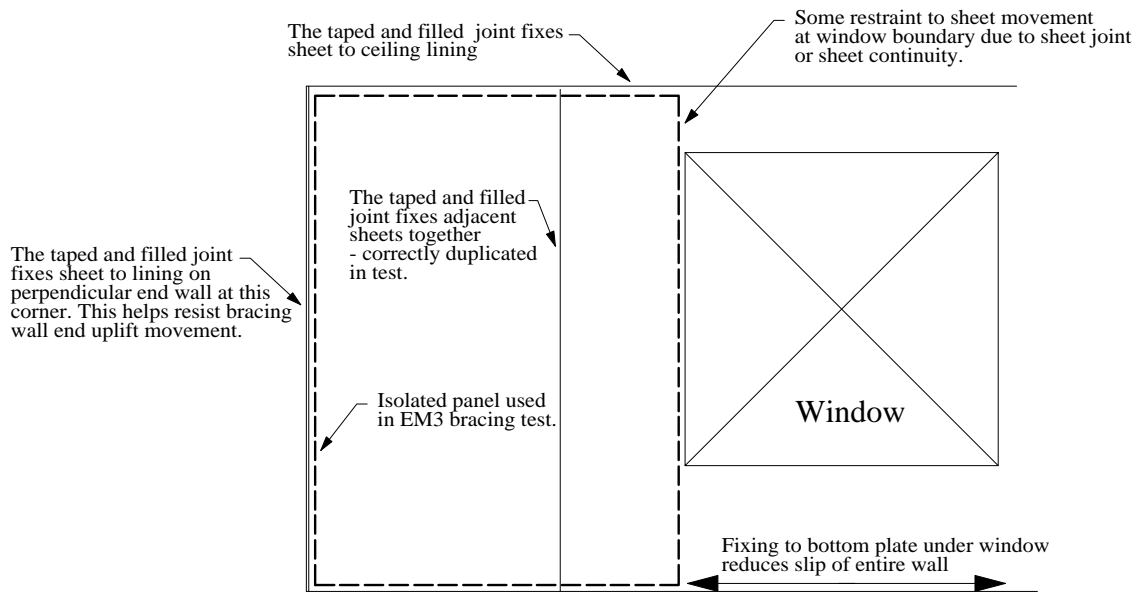


**Figure 2. Components of racking wall deflection and sketch of the BRANZ P21 uplift restraints**

### 3.3 'Systems effects'

Historically house wall lateral bracing has performed well in extreme wind and earthquake events, and this is attributed to 'systems effects' as discussed below. Many houses have more walls than required to resist the design loading, greater damping than assumed in the analysis, and lower periods than assumed. This means the house avoids the high accelerations assumed in the design and the houses are also lighter than assumed.

Full house tests reported by others (summarised by Thurston 2004) have noted that houses under racking load are stiffer and stronger than the sum of the individual wall panels due to the holistic response of the complete system. This includes load sharing and composite action, of both the structural and non-structural elements. The lateral restraint due to wall 'rocking' action is small, because of the transfer of house weights to the ends of the bracing elements. The taped and filled joints between plasterboard sheet lining at both wall ends and ceiling are expected to significantly increase wall racking strength due to the increased uplift restraint provided at wall ends, as illustrated in Figure 3. In addition the 'rigid' joints preclude the deformation mechanism of the wall lining sheet rotating about its centroid, as shown in Figure 2(d), to a stronger mechanism being pure translation along the bottom plate. The sheet-to-bottom plate connection strength is also enhanced by the zone under the windows.



**Figure 3. Restraint of wall lining in real buildings**

### 3.4 Comparison of the foundation details used in a P21 test and those used in actual construction

In a P21 test the foundation member is a composite beam consisting of a 19 mm thick particleboard strip fixed to the top of a 100 mm wide timber beam. The beam is fully restrained from movement by bolting it to steel test rig base as shown in Figure 4(a).

House bracing walls on concrete floors are usually fixed to the concrete with a proprietary masonry anchor or cast-in bolt as shown in Figure 4(c). End straps are also usually wrapped around the bracing element end stud (Figure 4(c)) to prevent the stud separating from the bottom plate. Many types of proprietary concrete anchorage fasteners are available.

A similar construction is now common for attaching bracing walls to timber floors with the concrete anchor replaced by a coach screw or through-bolt to a timber joist or blocking between joists. An alternative is to use a steel strap to fix wall end studs directly to timber joists (Figure 5(a)), or else to blocking as shown in Figure 5 (b). This is simulated in the P21 test by a strap fixing the wall end studs to the timber foundation beam. The timber floor tests (described in Appendix A) use a through-bolt to fix the walls to timber joist blocking as shown in Figure 4(b). The racking-induced tension force transmitted to the foundation will be similar for both these constructions.

It is worthwhile summarising the differences between a P21 test and usual house construction:

- (1) For simulation of construction on timber foundations the connection of the test wall to the foundation is similar to that used in practice except that any end straps and bottom plate nailing are connected directly to the foundation beam whereas in practice they may be connected to blocking between floor joists or directly to the joists. Coach screws and through-bolts are nowadays more common, having been recently introduced in the Winstone Wallboards (2006) bracing catalogue. These can be replicated in a P21 test. The tests used coach screws except where the writer wished to measure anchor forces; the coach screws were replaced with through-bolts and load cells were included.
- (2) For simulation of construction on concrete foundations any bolt, mechanical and chemical anchor fixing of the wall bottom plate to the concrete is replaced with

an M12 through-bolt in the test. It has historically been assumed that when the bracing wall is used in buildings that the M12 through-bolt can be replaced by a cast-in M12 bolt as described in Section 6.11.9 of NZS 3604:1999. However, replacement of the M12 through-bolt with any fixing should be based on assessment by a qualified engineer based on the required bracing rating and using the procedure discussed in Section 15.4.

Two other construction techniques used in practice are noted:

- (1) For construction where wall cladding overlaps and is fixed to floor joists or boundary members (e.g. fibre cement board exterior cladding) the cladding is often fixed directly to these floor members. This method of holding down bracing walls is considered in Section 5.2 as an example of specific design, and the manufacturers should assess that their anchorage system will not fail foundation members or suitable connections for the wall bracing rating should be published.
- (2) If the bottom plate is fixed to the concrete by power-driven nails, this may require the P21 tests for this situation to be done using a concrete foundation.

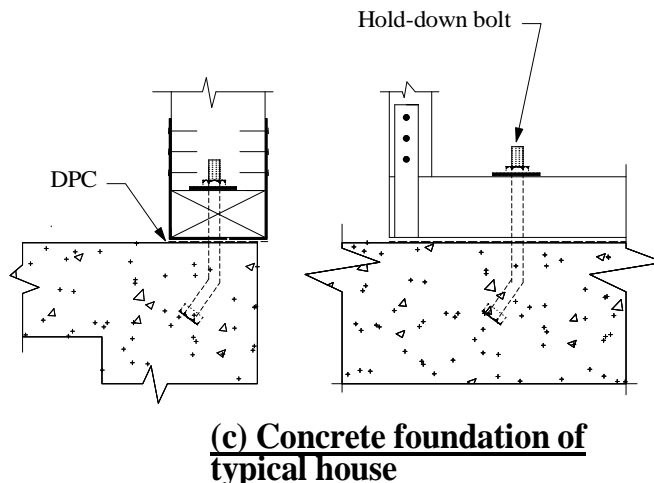
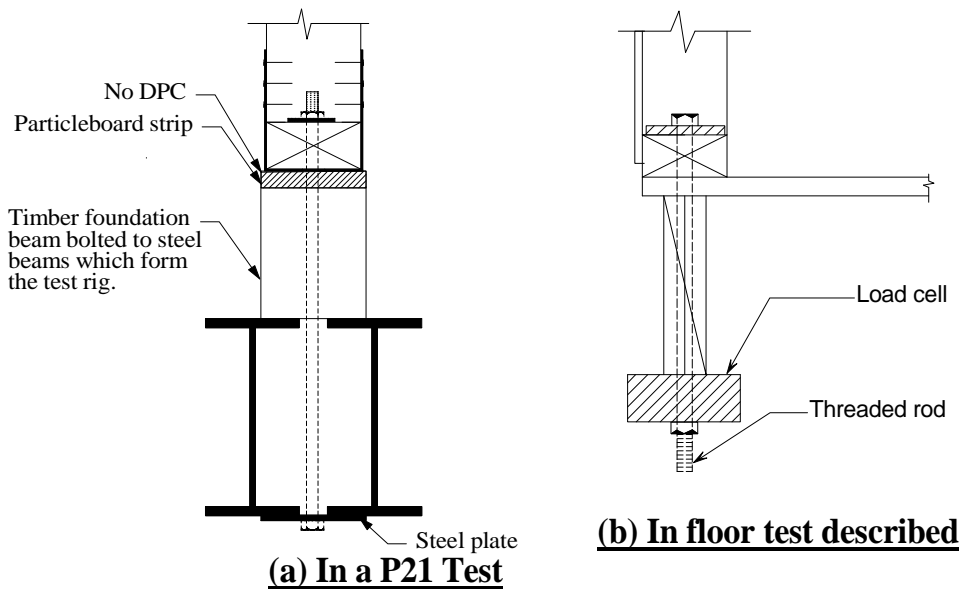
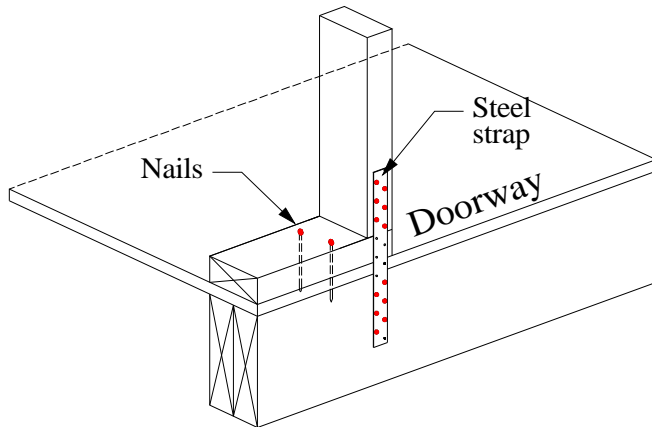
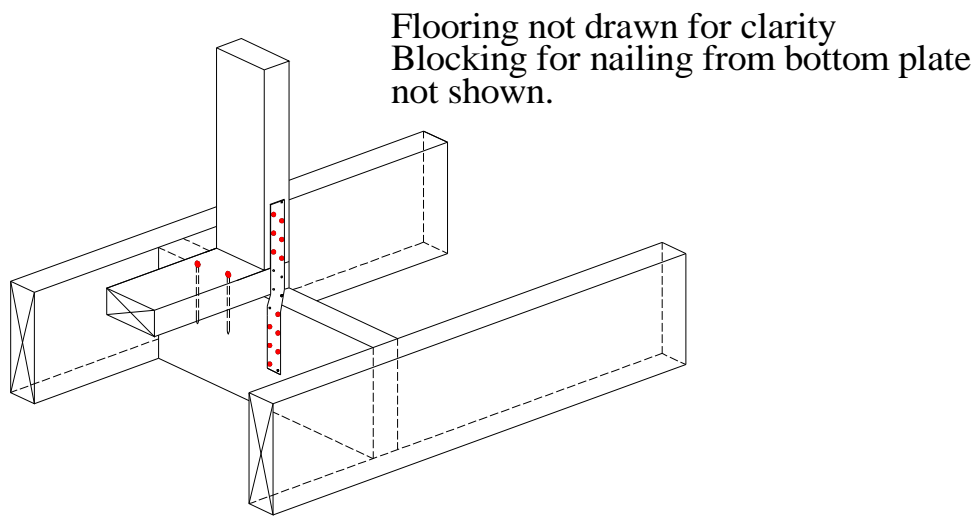


Figure 4. Using bolts to fix a wall to foundation



(a) Wall above joists



(b) Wall above blocking

Figure 5. Using straps to fix a wall-to-timber foundations

#### 4. USE OF STATISTICS IN DERIVATION OF DESIGN STRENGTHS AND DESIGN PHILOSOPHY

Most standards for the derivation of design parameters take into account the statistical spread of test results. However, the P21 method derives the design strengths based on the average of only three tests. Statistical methods to assess strength variability are not used due to the low number of replicate tests.

The P21 test does not take into account differences between site and laboratory construction (i.e. the strength reduction factor is set to 1).

This apparently unconservative approach is justified by noting the good historic performance of houses in major events (which is largely attributed to 'systems effects' – see Section 3.3), the rarity of such events, and the low life risk in the event of failure.

For the same reasons given above, it was decided that undue conservatism should not be used to determine 'maximum bracing ratings'. It is expected that this philosophy would ensure good performance in the design event for the bulk of structures which are designed to NZS 3604, although some connection and member failures will occur in some buildings. However, it is desirable to have a hierarchy of failure types to provide some protection over the more undesirable failure types from occurring. Walls damaged by racking can be fairly easily repaired, but failure of floor joists or bearers or their connections may be less easily detected and more expensive to repair.

The following approach was used:

- Walford (2006) advised that twice the characteristic timber strength was approximately the average timber strength. Hence the strength of timber members was taken as twice their characteristic strength (lower five percentile probability limit strength) using timber properties given in NZS 3603 (SNZ 1993) factored by a strength reduction factor of 0.8
- the strength of joints was taken as the minimum strength measured in the racking tests described in this study (i.e. using a strength reduction factor of 1.0)
- calculated joint strengths were taken as the average measured joint strengths from elemental testing given in the Appendices to this report factored by a strength reduction factor = 0.8.

## **5. APPLICATION OF BRACING RATINGS**

### **5.1 Publishing requirements**

As a marketing aid to selling their product, manufacturers test their proprietary bracing wall systems to the BRANZ P21 procedure and publish their results. The published information is not always complete. Generally the sheathing description and sheathing fastener type and spacing is provided. The distance from the edge of sheets to the first fixing in a row of fasteners is important as these corner fixings have a greater influence on bracing rating than the other fasteners do. Fastener edge distance is important and should be readily available (in the drawing defining the system) to the user of the bracing system. The location and details of hardware anchoring the wall is often ill-defined.

Any variation in the construction of the bracing system from that tested should be assessed to ensure it does not prejudice the bracing rating – preferably by the laboratory performing the test. Examples are changes in bracing wall height, sheet orientation and fastener type. The most glaring omission is the substitution of concrete anchors for the M12 bolt used in a P21 test. Manufacturers must either specify alternative anchors or else provide enough information for users of their systems to do this. Section 4 recommended that this be based on the lower five percentile anchor strength. The required anchor strength can be calculated as a function of the wall bracing strength as shown in Section 6.

### **5.2 Specific design**

Specifically designed systems need not be limited to the maximum rating recommended in this report. However, the design must ensure that an adequate load path exists. This includes the connections listed in Section 1. Other potential failure mechanisms must be checked.

## 6. BRACING WALL END REACTIONS

### 6.1 Introduction

The theoretical relationship between the wall hold-down anchor forces and wall bracing rating can be calculated using a static analysis as described in Section 6.2. However, the method requires knowledge of the input resistances, from building self-weight and the restraint imposed by adjacent construction. The lower end of the range of typical construction building weights was used in the analyses described in this report to ensure the results applied to most NZS 3604 buildings, but without being unduly conservative.

The equations use a force to represent the restraint of uplift movement imposed by the adjacent wall panel. This is simulated in a P21 test by a P21 uplift restraint (as discussed in Section 3.2). Appendix D presents test data on the magnitude of the P21 'three-nail' uplift restraint – being 4.5 kN at 4 mm vertical deflection. From extensive testing, Thurston (2006(a) and (b)) found that the uplift and downward restraint could be conservatively estimated to be 9 kN for normal construction with taped and stopped plasterboard joints at both wall ends and ceilings, provided the wall terminated in a corner or at windows or doors. This is adopted herein. At a full wall height opening the hold-down strength was close to 4.5 kN. For internal walls with a taped ceiling connection, but no end continuity, the value was determined to be between 0 and 4.5 kN for construction on blocking between joists. However, this reached more than 9 kN when the wall was directly over a joist, due to the axial load attracted to the uplifting corner.

### 6.2 Calculation of bracing wall end anchor forces and end reactions

Figure 6 shows the external forces on a 2.4 m high bracing wall. The reactions 'A' and 'R' shown in this figure are calculated in Equations (1) and (2) respectively. The total load path from the wall to the ground must be adequate to resist these reactions. The upwards reaction 'A' should be used to check anchor suitability where substitute anchors are to be used and to design the connection between floor members e.g. joist-to-bearer connection strengths. The downward reaction, 'R', should be used to ensure bearers and joists have adequate strength and that member connection strength for this load direction is adequate.

Figure 6 includes vertical gravity loads on the wall. W1 is the panel self-weight based on a weight per unit area of 0.4 kPa. The weight on the panel from the structure above, W2, has been assumed to act at the 'lifting' end of the panel, and is taken as 5.5 kN where there is a floor above and 0.6 kN where there is not. These were calculated using the same weights which are the basis of NZS 3604:1999 seismic design and assumed tributary areas.



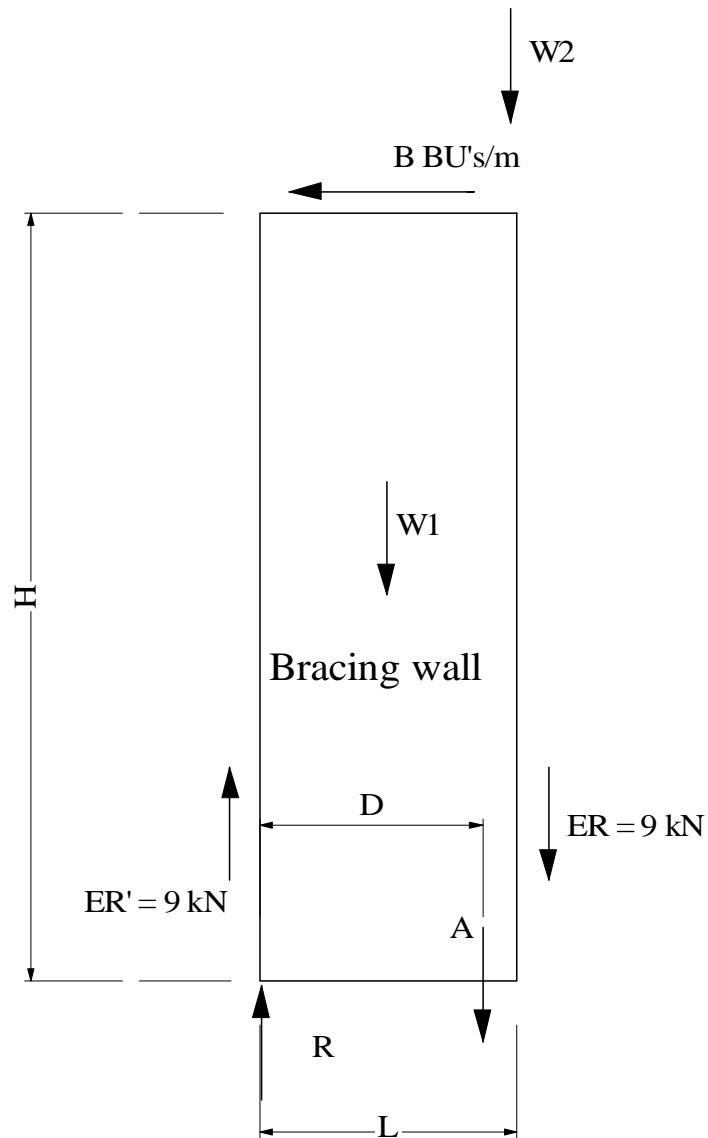


Figure 6. Rocking forces on bracing panel

**Hold-down anchor (tension) force, A (kN)**

$$A = (L/D) \times (B \times H/20 - ER - \{W1\}/2 - W2) \quad \dots\dots (1)$$

**Downward reaction force, R (kN)**

$$R = B \times H/20 - ER' + \{W1\}/2 + A(L-D)/L \quad \dots\dots (2)$$

The following scenarios were considered:

1. Whether the bracing wall has either no floors above or otherwise has at least one floor above.
2. Whether the bracing wall is founded on a timber or concrete floor.

### 6.3 Wall end reaction tables

The calculated end reactions using equations (1) and (2) are given in Table 1 and Table 2 for anchor uplift reaction and downward reaction respectively. Thus, if the foundation strength for a particular building is known, then the maximum wall bracing ratings can be determined directly from these tables. For example, for the situation where there is no floor above, and the concrete anchor strength is separately determined to be 17 kN, then bracing walls which are at least 0.9 m long may have a design strength of 200 BU's/m.

The tables have been calculated using the load combination of G & Qu & Eu as specified in AS/NZS 1170.0. The tables for concrete foundations have assumed that L-D = 0.15 m, whereas for timber foundations it is assumed that wall hold-down is end straps connected directly to the floor joists or bearers and L-D = 0.

**Table 1. Calculated uplift reaction for combinations of racking load and panel length**

(a) Anchor bolts into concrete floors

Panel length (m)	<b>Bolt tension force A (kN)</b>				
	<b>Racking load (BU's/m)</b>				
	100	120	150	180	200
<b>Bracing walls with one floor above.</b>					
0.40	0.0	0.0	5.3	11.0	14.9
0.60	0.0	0.0	4.3	9.1	12.3
0.90	0.0	0.0	3.7	8.0	10.9
1.20	0.0	0.0	3.3	7.4	10.2
1.80	0.0	0.0	2.9	6.8	9.4
2.40	0.0	0.0	2.5	6.3	8.9
<b>Bracing walls with no floor above.</b>					
0.40	3.5	7.4	13.1	18.9	22.7
0.60	2.8	6.0	10.8	15.6	18.8
0.90	2.4	5.2	9.6	13.9	16.8
1.20	2.1	4.8	8.9	13.1	15.8
1.80	1.7	4.3	8.2	12.1	14.8
2.40	1.3	3.9	7.7	11.6	14.1

(b) End straps to timber floor members

Panel length (m)	<b>Strap tension force A (kN)</b>				
	<b>Racking load (BU's/m)</b>				
	<b>100</b>	<b>120</b>	<b>150</b>	<b>180</b>	<b>200</b>
<b>Bracing walls with one floor above.</b>					
0.40	0.0	0.0	3.3	6.9	9.3
0.60	0.0	0.0	3.2	6.8	9.2
0.90	0.0	0.0	3.0	6.6	9.0
1.20	0.0	0.0	2.9	6.5	8.9
1.80	0.0	0.0	2.6	6.2	8.6
2.40	0.0	0.0	2.3	5.9	8.3

<b>Bracing walls with no floor above.</b>					
0.40	2.2	4.6	8.2	11.8	14.2
0.60	2.1	4.5	8.1	11.7	14.1
0.90	2.0	4.4	8.0	11.6	14.0
1.20	1.8	4.2	7.8	11.4	13.8
1.80	1.5	3.9	7.5	11.1	13.5
2.40	1.2	3.6	7.2	10.8	13.2

Table 2. Calculated wall downward reaction for combinations of racking load and panel length

(a) Anchor bolts into concrete floors

Panel length (m)	<b>Downward reaction force R (kN)</b>				
	<b>Racking load (BU's/m)</b>				
	<b>100</b>	<b>120</b>	<b>150</b>	<b>180</b>	<b>200</b>
<b>Bracing walls with one floor above.</b>					
0.40	3.2	5.6	11.2	16.9	20.8
0.60	3.3	5.7	10.4	15.2	18.4
0.90	3.4	5.8	10.0	14.4	17.2
1.20	3.6	6.0	10.0	14.1	16.8
1.80	3.9	6.3	10.1	14.0	16.6
2.60	4.2	6.6	10.3	14.1	16.7

<b>Bracing walls with no floor above.</b>					
0.40	4.5	8.4	14.1	19.9	23.7
0.60	4.0	7.2	12.0	16.8	20.0
0.90	3.8	6.7	11.0	15.3	18.2
1.20	3.8	6.6	10.7	14.8	17.6
1.80	4.0	6.6	10.5	14.5	17.1
2.60	4.2	6.8	10.6	14.5	17.0

(b) End straps to timber floor members

Panel length (m)	Downward reaction force R (kN)				
	Racking load (BU's/m)				
	100	120	150	180	200
<b>Bracing walls with one floor above.</b>					
0.40	3.2	5.6	9.2	12.8	15.2
0.60	3.3	5.7	9.3	12.9	15.3
0.90	3.4	5.8	9.4	13.0	15.4
1.20	3.6	6.0	9.6	13.2	15.6
1.80	3.9	6.3	9.9	13.5	15.9
2.60	4.2	6.6	10.2	13.8	16.2

<b>Bracing walls with no floor above.</b>					
0.40	3.2	5.6	9.2	12.8	15.2
0.60	3.3	5.7	9.3	12.9	15.3
0.90	3.4	5.8	9.4	13.0	15.4
1.20	3.6	6.0	9.6	13.2	15.6
1.80	3.9	6.3	9.9	13.5	15.9
2.60	4.2	6.6	10.2	13.8	16.2

Walls may have additional fixings (nails or bolts) between the wall bottom plate and foundation than those assumed in Figure 6. These will induce tension forces between the wall and the foundation in other positions when the wall is racked. Equation (1) can simply be adjusted to include these forces – if they are known. Test data in Appendix C gives the two-nail pull-out strength as 3.08 kN. However, the lining fixing to the bottom plate may fail before sufficient force is transferred from the lining to the bottom plate to pull out these fixings, as shown in Figure 7. Bottom plate rotation shown in Figure 8 can result in the fixing pull-out load being lower than would occur in a concentric loading situation.

By taking moments about the wall corners, it can be shown that the presence of nail fixings tend to reduce the anchorage tension force, 'A', but increases the end downwards reaction, 'R'. However, the foundation below the wall is still subjected to the combined tension force from all connections from the wall to the foundation. The effect of these the additional fixings has not been included in Table 1 and Table 2.

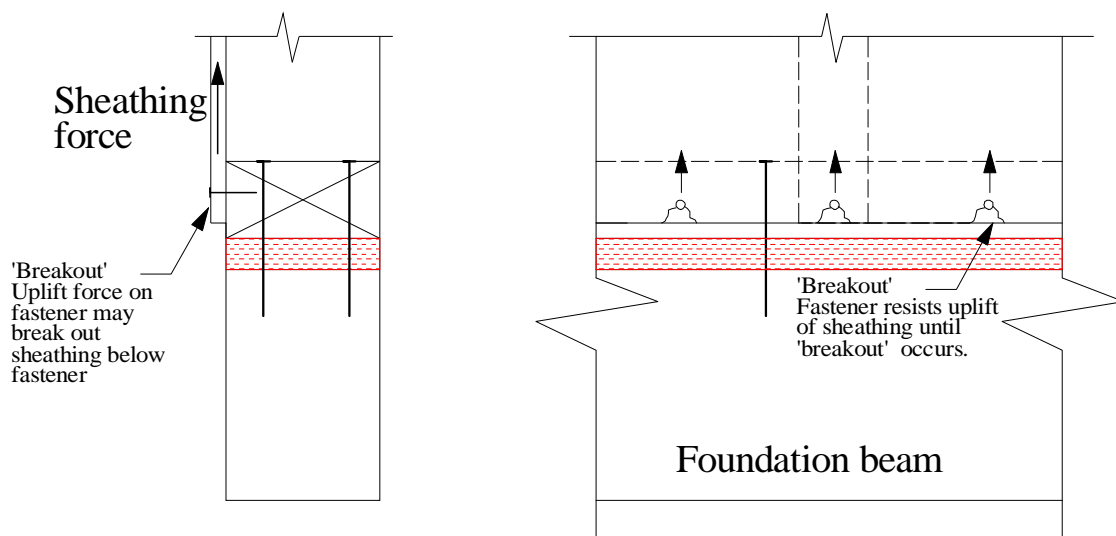
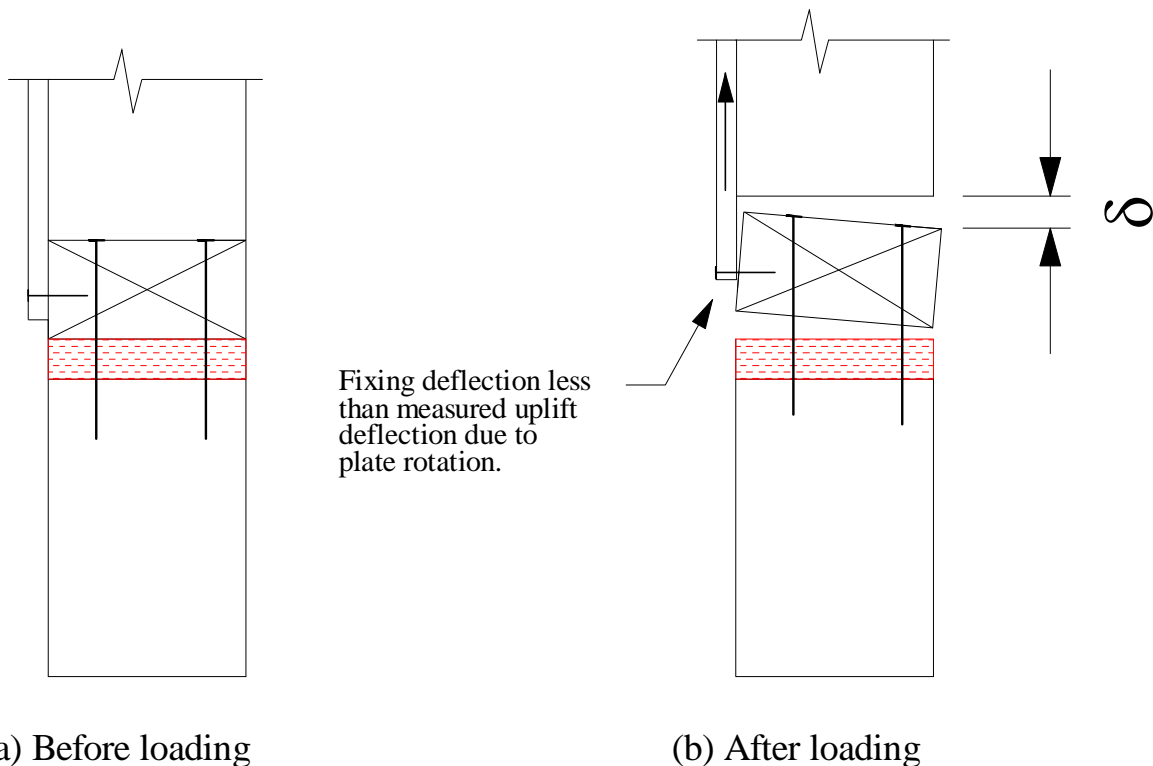


Figure 7. Transfer of sheathing uplift force to bottom plate via bottom plate nails



**Figure 8. Rotation of bottom plate in a wall sheathed on one side only**

If a bracing wall is governed by the anchor strength, then the additional bottom plate nails will increase the wall 'rocking' strength. Assume that the wall sheathing is sufficiently strong that a nail pull-out strength of  $F_n = 3.1$  kN for a pair of nails can be relied upon. This means that for a given anchorage force, 'A', a 1.2 m long wall with bottom plate nails at 600 mm centres can provide an increase in bracing per unit length of  $= \sum(F_n \cdot X_i) \cdot 20/H/L = 3.1 \times (1.1 + 0.5) \times 20/2.4/1.2 = 34$  BU's/m where  $X_i$  is the distance from nail pair 'i' to the compression toe of the wall. This is significant.

## 7. GETTING THE LOAD INTO A BRACING WALL

### 7.1 Introduction

In a P21 test the top plate is loaded directly. The P21 test measures the ability of the wall to transmit this load to the foundation. This section determines the maximum load that can get into a bracing wall in a real NZS 3604 type building.

Horizontal loads from earthquake or wind can be transferred into a bracing wall by the following mechanisms:

- From the ceiling or roof to the wall top plate at a location either away from or at the bracing wall. The top plate can act as a collector element to carry the transverse load to the bracing wall.
- For construction with taped and stopped plasterboard joints between the wall and ceiling, the load can be transmitted directly from the ceiling, through the joint and thus into the wall lining.

## 7.2 Transmission via top plate

Load to a top plate of a bracing wall can be transmitted directly through the roof or ceiling connection over the length of bracing wall. It can also be transmitted along the top plate from another portion of house as noted above. However, the top plate may not be continuous, and it is assumed that it is butt jointed with a mechanical connection of each end of the bracing wall. Figure 9 shows a diagrammatic view of the load transfer. It is assumed that there is an axial force of  $F_1$  and  $F_2$  in the top plate at the two ends of the bracing wall as shown, but that the load transferred to the bracing wall via the top plate is limited by the strength of the top plate connectors  $F_3$  and  $F_4$ . The force transmitted to the bracing wall due to the ceiling/roof connection over its length,  $L$ ,  $= fL$ . Thus the maximum load in the bracing wall,  $F_5 = fL + F_3 + F_4$ .

The provisions in NZS 3604 for joints in top plates are contained in Section 8.7.3.3. A 3 kN connection is required where the wall contains a bracing element of up to 100 BU's (5 kN), and 6 kN where the element is greater than 100 BU's. With regard to this project it can be considered that a 6 kN top plate connection exists at the two parallel vertical lines shown in the top plate in Figure 9. Bracing walls in the middle of long walls can be loaded from the plate on both sides which gives a total load of 12 kN which can be transmitted to the bracing wall. For bracing walls at wall corners NZS 3604 Section 8.7.3.4 requires a 6 kN connection at the corner, which again provides a total of 12 kN load which can be transmitted to the bracing wall.

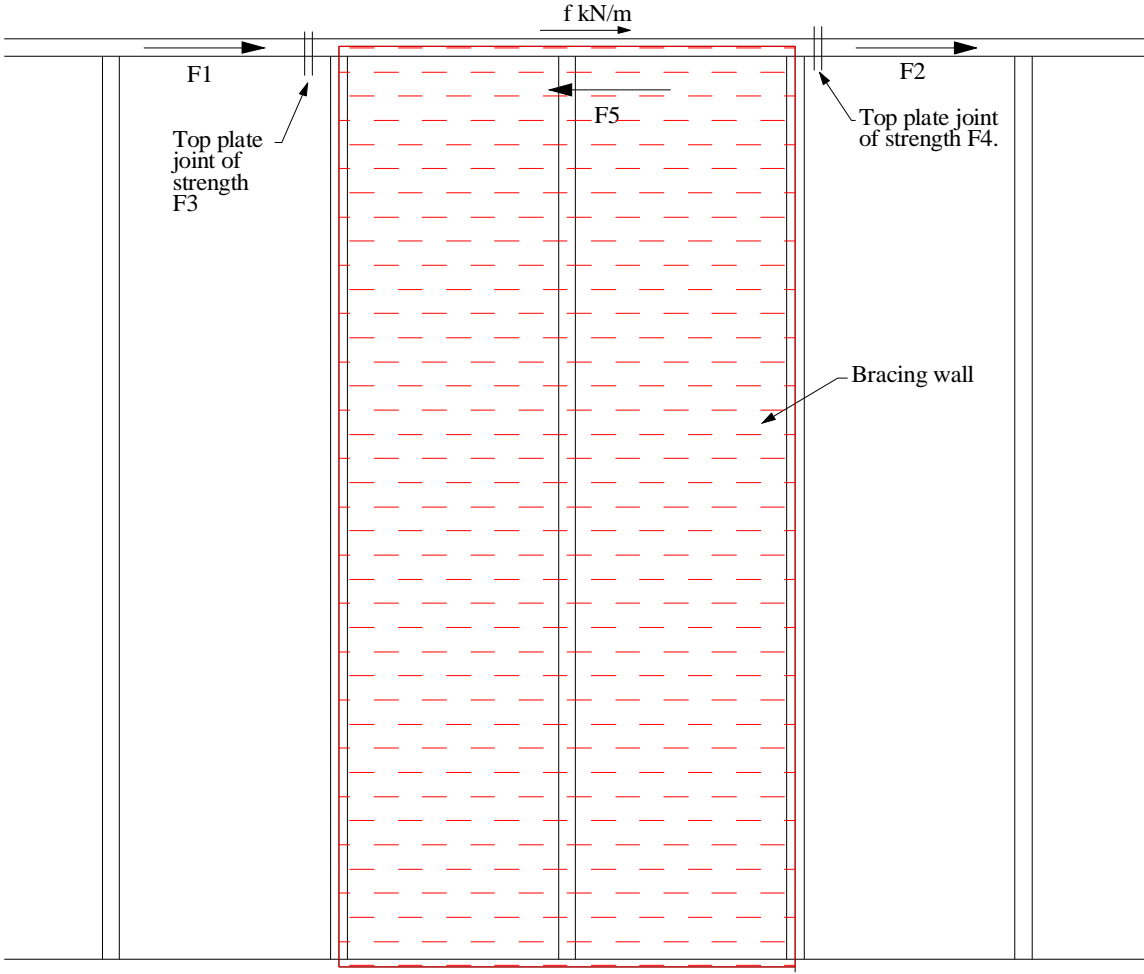


Figure 9. Transmission of force from top plate into bracing wall

### 7.3 Transmission via ceiling-to-bracing wall

Shelton (2004) measured the strength of wall-to-ceiling joints parallel to the wall as:

- No finish at wall/ceiling joint – 2.57 kN/m.
- Plasterboard coving joint – 4.17 kN/m.
- Timber scotia joint – 4.17 kN/m.

In this project, Thurston (see Appendix B), the strength of paper-taped and stopped joints was measured to be 5.8 kN/m.

### 7.4 Transmission via both mechanisms

It is assumed that there is some finish to the wall/ceiling joint. Thus, the critical case is plasterboard coving or timber scotia which results in the maximum strength that can be relied upon to be transmitted to a bracing wall of 4.17 kN/m + 12 kN.

This gives the maximum bracing rating of some typical wall lengths as:

- 0.6 m long wall: 483 BU's/m; calculated from  $(4.17 \times 0.6 + 12) / 0.6 \times 20$
- 1.2 m long wall: 283 BU's/m.
- 1.8 m long wall: 216 BU's/m.
- 2.4 m long wall: 183 BU's/m.

The maximum bracing rating compatible with getting the load into the wall is taken as a rounded down value of the minimum of the above – namely: 180 BU's/m.

## 8. MAXIMUM BRACING RATING FOR WALLS ON CONCRETE FOUNDATIONS

### 8.1 Background

The following aspects which are relevant to this section have already been discussed in this report:

- Section 3.4: substituting concrete anchors for M12 bolts used in P21 tests.
- Section 4: the recommendation that alternative anchor design be based on anchor lower five percentile strength with  $\phi$  (strength reduction factor) = 1.
- Section 5.1: the manufacturer's responsibility to specify alternative anchors when publishing their bracing systems for use on concrete foundations.

### 8.2 Exterior walls

Figure 4(a) depicts the arrangement of bottom plate fixing used in a P21 test. Figure 4(c) depicts the arrangement of bottom plate fixings used in a typical house construction. Although it shows a cast-in steel bolt, other alternative anchors may be used. Some differences between the construction used in the test and that used in houses are apparent:

- No bituminous damp-proof course (DPC) is used beneath the bottom plate in the test.
- The bolt is central to the bottom plate in the test, but is usually offset in houses to provide a greater bolt holding strength in the concrete (see the discussion below).

- The bottom plate is central to the support in the test, whereas in houses it overhangs the edge of the concrete foundation by at least 6 mm (as stipulated in Figure 7.10 of NZS 3604). Note that some cladding manufacturers' literature specifies an overhang of 10 mm.

To develop the greatest pull-out strength of the bottom plate anchor into the concrete, the anchor edge distance needs to be maximised. Thus, the anchor is generally specified as being offset from mid-width of the 90 x 45 mm bottom plate. The limit to the offset is the potential intrusion of the 50 x 50 mm washers beyond the inside face of the bottom plate (which would interfere with the wall linings). This gives a maximum distance from the bolt centreline to the edge of the concrete foundation as  $90 - 50/2 - 6 = 59$  mm. Most BRANZ tests on proprietary anchors have been performed using a 50 mm edge distance from the concrete, although some early tests used lesser distances depending on the specification of the anchor manufacturer.

The pull-out strength of a correctly installed concrete anchor is a function of:

- (1) anchor details, including type (glued, sleeve or threaded) and length
- (2) concrete strength
- (3) edge distance
- (4) anchor spacing
- (5) concrete reinforcement.

It is assumed that bottom plate anchor spacing is adequate to ensure the anchor strength is not reduced by item (4) above.

Those using test data to ascertain anchor strength should ensure that the test data is not reliant on the proximity of concrete reinforcement (item (5)), which may not be present when the bracing wall is used in actual construction.

BRANZ has tested many anchor systems of various types since the introduction of NZS 3604:1999 – some of these as commercial projects for clients and some in research testing. The tests used close to the minimum 28 day concrete strength of 17.5 MPa specified in Section 4.8.2 of NZS 3604:1999. Tests were done with both masonry block edges and also concrete poured using conventional shuttering. The cast-in M12 bolts tested were bent before installation to prevent turning when tightening the nut, and were set to an embedment depth of 75 mm as stipulated in Section 6.11.9 of NZS 3604. The tests and data reduction was performed according to the BRANZ *Evaluation Method No 1* (BRANZ 1999). The test results for some generic anchor types are summarised in Table 3.

Table 3 also includes bracing values calculated using the model in Figure 6 and the average anchor characteristic strength. Longer and also more effective anchors will give even higher bracing values. The values indicate that suitable anchors can be found so that for practical purposes maximum bracing rating need not be limited by anchor pull-out strength.



**Table 3. Typical anchor strengths and corresponding range of maximum bracing ratings**

Anchor type	Foundation side form	Edge distance (mm)	Range of strengths (kN)		Maximum bracing ratings* BU's/m
			Mean	Characteristic	
<b>Cast-in M12 bolts</b>	Masonry block	<b>50</b>	<b>22-24</b>	---	
	Conventional shutter	<b>50</b>	<b>22-24</b>	<b>18</b>	206
	Conventional shutter	<b>37</b>	<b>15</b>	<b>9</b>	141
	Masonry block	<b>35</b>	<b>15-22</b>	<b>11 - 13</b>	163
<b>150 mm long screwed M12 anchors</b>	Masonry block	<b>50</b>	<b>19-24</b>	<b>13 - 20</b>	195
	Conventional shutter	<b>37</b>	<b>17</b>	<b>13</b>	170
	Conventional shutter	<b>50</b>	<b>24</b>		
<b>Chemical stud anchors 12 mm diameter, 160 mm long</b>	Masonry block		<b>16-20</b>	<b>10-17</b>	173
<b>Expansion mechanical anchors (Sleeve or wedge)</b>	Masonry block	<b>50</b>	<b>13.5</b>	<b>7.5</b>	130
	Conventional shutter	<b>50</b>	<b>15-19</b>	<b>11.5 - 15.5</b>	173
	Conventional shutter	<b>37</b>	<b>6-13</b>	<b>3 - 9</b>	119
	Masonry block	<b>40</b>	<b>8.5-12</b>	<b>3 - 5</b>	104

\* Note this maximum bracing rating has been calculated for a 1200 mm long wall with zero axial load and average characteristic strengths and using the model in Figure 6.

### 8.3 Interior walls

Figure 6.16a of NZS 3604 implies that bolts must be embedded 75 mm into the concrete floor. Floor thickening is required under loadbearing walls, but bracing walls which are fixed to a slab may not be loadbearing and therefore this thickening is not required by the standard. The minimum floor thickness is 100 mm. This leaves only  $100 - 75 = 25$  mm cover under the bolt head which may result in durability problems. For other situations NZS 3604 requires 75 mm cover. However, a DPC is required under the slab which will provide some durability protection to the bolt. There is a risk of holes drilled for alternative anchors penetrating the DPC, particularly for the slab types in shown in Figure 7.16 (b) and (c) of NZS 3604, where the DPC is at 50 and 75 mm depths respectively.

BRANZ has no test data for anchors used with anchor depth less than 75 mm which is what is appropriate for fixing internal walls. Note that anchor edge distance is not relevant for this situation unless the anchor is near a shrinkage control joint. Local slab thickening may be required if the anchor strengths are too low, or the risk of DPC penetration is high.

It is recommended that Standards New Zealand revisits the bolting down of internal bracing walls, taking into account aspects raised above.

### 8.4 Failure of concrete foundations in flexure

The case analysed is for an internal wall on a 100 mm deep slab reinforced with SE62 mesh (area =  $141 \text{ mm}^2/\text{m}$  in both directions) at a depth of 30 mm from the top of the slab (refer to Figure 7.16 of NZS 3604.)

The concrete strength is taken as 17.5 MPa and the yield strength of the steel is taken as 480 MPa. Using standard concrete theory the ultimate bending strength of the slab is ( $M^- = 4.58 \text{ kNm/m}$  and  $M^+ = 1.87 \text{ kNm/m}$ ).

It is assumed that an upward load at Point C of Figure 10 induces the yield lines shown. They are shown dotted for the negative moment (cupping) and as solid lines for the positive moment (hogging). From yield line theory (Park and Gamble 2000), the maximum uplift load, P, that can be applied at a point on a slab before a mechanism occurs can be found from virtual work using the following equation, where  $\Delta$  is the uplift at P.

$$P\Delta = (M^+ + M^-) \times \Delta \times 2\pi = (1.87 + 4.58) \times \Delta \times 2\pi$$

Solving gives  $P = 40.5 \text{ kN}$ . This is significantly greater than anchor failures given in Table 3 and is therefore unlikely to be critical.

If the failure mobilises a large slab area the floor weight (and suction to lift it) must be added to the virtual work equation. In the extreme case the floor weight (and suction to lift it) within the circle of negative moment yielding is a total force = P. The average uplift movement of these forces =  $\Delta/3$ . The virtual work equation can now be rewritten:

$$P\Delta = P\Delta/3 + (M^+ + M^-) \times \Delta \times 2\pi$$

and  $P = 60.75 \text{ kN}$ . Clearly this is even less critical.

Although the slab may not be ductile enough to develop a full yield pattern, concrete slab failure is still unlikely to be critical. This conclusion also applies to uplift forces applied by exterior walls as the flexural strength of the local footing is even greater.

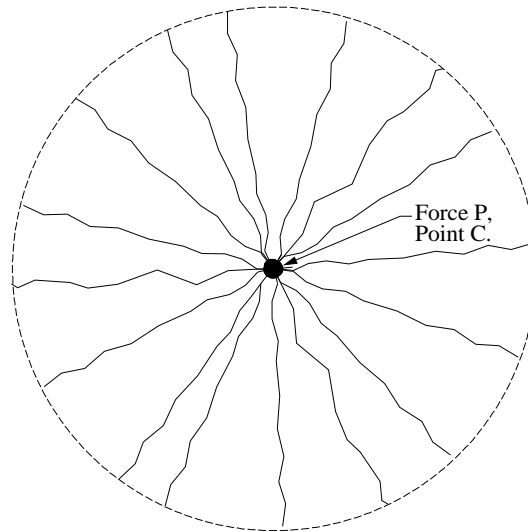


Figure 10. Yield line crack pattern in concrete slab

## 9. MAXIMUM WALL BRACING RATING BEFORE FAILURE OF BOTTOM TIMBER PLATE

### 9.1 Background

In some P21 tests the bottom plate has failed in flexure, as illustrated in Figure 11. Thurston (2007(b)) also reports on and provides photographs of two failures in a full-scale room test. The timber flexural crack passed through the hole for the M12 hold-down bolt. This is an undesirable mechanism as it is a brittle failure and occurs behind wall sheathing and therefore is likely to miss detection after a major earthquake or wind event. As the P21 test only consists of three specimens, and as these may have a bottom plate flexural strength at the hold-down bolt location greater than average (i.e. be free of knots and defects at this location), it is possible that it may not fracture in the P21 tests, whereas the break may occur within many bracing walls in practice. Consequently, it was decided that wall maximum bracing rating limits should be set so that bottom plate failures are rare in design level events. Approximate calculations to achieve this are given below.

### 9.2 Bottom plate flexural strength

At the critical section, the timber plate is reduced in thickness by the bolt hole diameter to  $90-12 = 78$  mm. The latest revision to NZS 3603 (SNZ 1993) specifies that the characteristic bending strength of MSG8 timber is 14 MPa. Thus, a  $90 \times 45$  mm grade timber bottom plate has a characteristic strength of  $14 \times 78 \times 45^2 / 6 \times 10^{-6} = 0.369$  kNm. The average strength is often taken as twice the characteristic strength, which in this instance becomes  $2 \times 0.369$  kNm = 0.737 kNm. If a strength reduction factor of 0.8 is also introduced the design strength becomes 0.59 kNm.

### 9.3 Bracing load at which the timber plate flexural strength is exceeded

Consider a 1.245 m long wall with the end studs rigidly strapped to the bottom plate and with a bottom plate anchor fixed into concrete at 100 mm from the ends of the wall, as illustrated in Figure 11. The force S shown is the tension force in the end stud, and

the force in the hold-down anchor is A kN. The bending moment at the bottom plate anchor is therefore:

$$M = A\{(1200-78)/1200\} \times 0.078 = 0.073A \text{ kNm.}$$

Equating the loading to the bending strength of the bottom plate of 0.59 kNm gives  $A = 8.08 \text{ kN}$ .

The corresponding wall bracing force (B BU's/m) can be computed using the forces shown in Figure 6:

$$B = 9/H + A \times D/(H \times L). \text{ Hence } B = 9/2.4 + 8.08 \times 1.1 / (2.4 \times 1.2) = 6.84 \text{ kN/m (137 BU's/m)}$$

If the bolt is placed 200 mm from the outside face of the stud rather than 100 mm, then B becomes 105 BU's /m using the above calculations.

Note that some bracing systems transfer the tension force in the end stud directly to the foundations by use of steel angle or straps, and thus do not load the bottom plate in flexure.

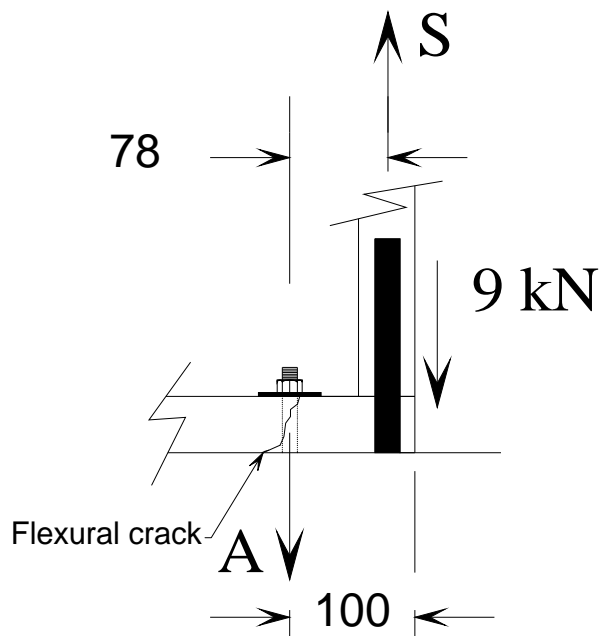


Figure 11. Flexural loading of bottom plate

## 10. MAXIMUM WALL BRACING RATING TO CAUSE BEARER OR JOIST FAILURE

### 10.1 Introduction

This section provides the results of an analysis to determine the bracing rating of a wall directly above a bearer or joist which will result in the member flexural failure. The timber strength is based on twice the predicted strength from NZS 3603:1993 with the strength reduction factor ( $\phi$  factor) taken as 0.8. The philosophy for this is discussed in Section 4.

A popular wall bracing system uses a bolt or coach screw fixing from the wall bottom plate into blocking or joists directly below the wall. If the connection is into a joist (or

bearer) the predicted flexural strength of the timber member will be reduced due to the loss of cross-section at the hole location. Tables of maximum bracing rating are given in Section 10.3.1 for both interior and exterior joists, and also for construction both with and without a 12 mm hole for a selection of joist sizes and joist spacing.

It is assumed that no holes are drilled into bearers.

## **10.2 Determination of loads transmitted to bearers and joists from bracing walls**

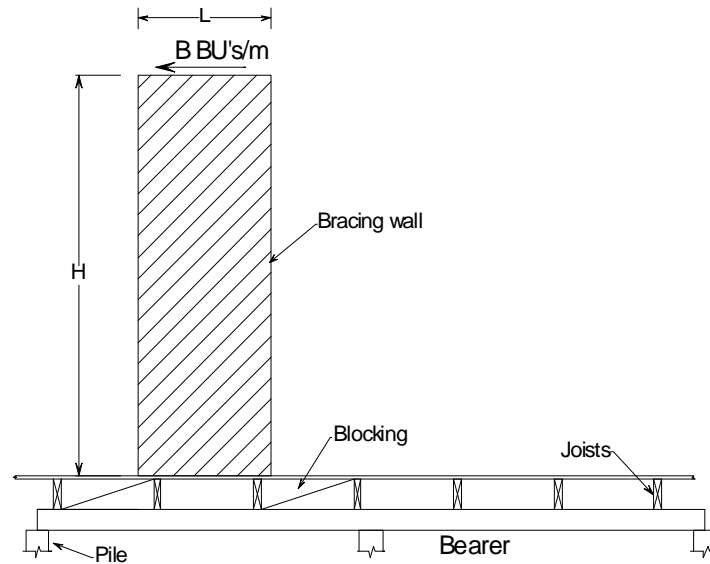
The flexural demand on bearers and joists is calculated below based on gravity loading, plus that computed from the vertical forces transmitted to these members from wall racking loads. These vertical forces are the bracing wall end reactions.

Section 6.2 provides equations for estimating wall end reactions. The equations include restraining forces of 9 kN at both the tension and compression ends of a bracing wall which resist wall vertical movement at these locations. The 9 kN value was based on tests on external walls with normal end continuity construction (Thurston 2007(a) and 2007(b)). If the house has no lining or the lining does not have strong plastered joints these restraints will be significantly less and greater loads will be transmitted to joists and bearers from the bracing elements – i.e. these will fail at lower wall bracing forces. In Phase II and III of this project, Thurston (1993) showed the end continuity forces may be less than 9 kN for walls terminating at full wall height openings or doorways.

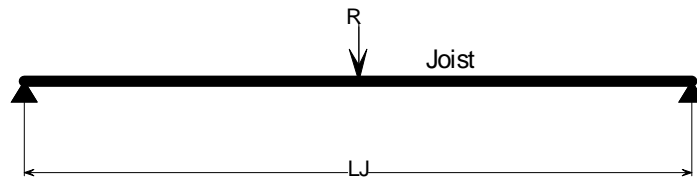
From an examination of Figure 6, if W1 and W2 are significant, then the magnitude of R is greater than A and thus only downward compressive reaction (R) is considered in the analysis below.

## **10.3 Maximum bracing rating to cause joist failure**

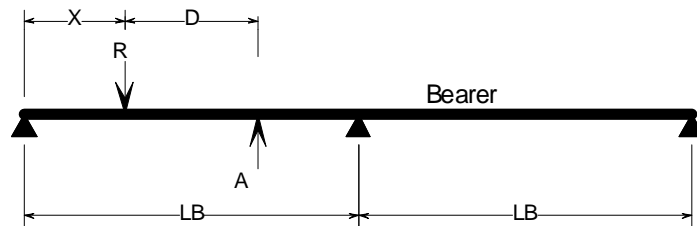
Figure 12(a) shows the loading and Figure 12(b) shows the model used to determine the maximum joist bending moment. The bracing force B (BU's/m) can be in either horizontal direction, and so the absolute value of joist bending moments should be added to those produced by gravity loading. The most critical situation is the wall orientated perpendicular to the joists with the compression end located at joist mid-span (with no blocking being present), although loading from a wall directly above and parallel to a joist can produce similar bending moments.



**(a) Construction**



**(b) Model to determine maximum joist bending moment**



**(c) Model to determine maximum bearer bending moment**

**Figure 12. Loading on joists and bearers**

### 10.3.1 Exterior double joists

Section 7.1.3 of NZS 3604 (SNZ 1999) requires pairs of joists to be used beneath loadbearing walls where the joists are parallel to the walls. The wall bracing rating to cause joist failure for an exterior double joist with a 12 mm hole, based on the assumptions given in Section 10.1 and 10.2, is given in Table 4 for grade MSG 8 timber.

A sample calculation is given below using the terminology given in Figure 6 and equations (1) and (2).

Consider a double 140 x 45 floor joist at a nominal spacing of 400 mm centres where the floor uniform distributed load (UDL) including self-weight is 0.6 kPa at the time of the earthquake/windstorm.

The mid-span joist positive bending moment due to gravity =

$$M = \frac{wL^2}{8} = \frac{0.4 / 2 \times 0.6 \times 2.7^2}{8} = 0.11 \text{ kN.m}$$

NZS 3603:1993 provides an expression for the joist flexural strength,  $\phi M_n > M^*$ .

$$\phi M_n = \phi \times K_1 \times K_4 \times K_5 \times K_8 \times f_b \times Z = 0.8 \times f_b \times Z$$

Using the assumptions in Section 4, the member strength =  $2 \times 0.8 \times M_n = 2 \times 0.8 \times 14 \times (90-12) \times 140^2 / 6 \times 1.0 \text{ E-6} = 5.71 \text{ kNm}$ .

Thurston (2007(a)) showed that this could be factored by 1.08 factor to account for load sharing between joists.

The bending moment on a single span joist of length L subjected to a point load R at midspan =  $RL/4$ . Thus, including the floor gravity load:

The value of R to cause joist failure =  $1.08 \times (5.71 - 0.11) \times 4 / 2.7 = 8.96 \text{ kN}$ .

To calculate the wall self-weight,  $W_1$ , assume the wall weighs  $0.3 \text{ kN/m}^2$  and that it is 2.4 m long.

Hence,  $W_1 = 2.4 \times 2.4 \times 0.3 = 1.73 \text{ kN}$ .

As a first guess, set  $B = 136 \text{ BU's/m}$  and set  $D/L = 0.9$ .

Thus, from eqn (1),  $A = (1/0.9) \times (136 \times 2.4/20 - 9 - 1.73/2) = 7.23 \text{ kN}$ .

Hence, from eqn (2),  $B = 20/H \times (8.96 + 9 - 1.73/2 - 0.1 \times 7.23) = 136 \text{ BU's/m}$ .

Hence, the guess was correct.

Note that  $B = 136 \text{ BU's/m}$  corresponds to the value given in Table 4.

**Table 4. Maximum bracing rating for exterior (double) floor joists with a 12 mm hole**

(Bracing values shown are in units of BU's/m)

Floor joist size (Doubled)	Joist spacing (mm)		
	400	450	600
90 x 35	111	112	117
90 x 45	121	123	131
140 x 35	134	137	146
140 x 45	136	139	163
190 x 45	163	166	177
240 x 45	191	194	208
290 x 45	219	224	241

Walls below gable ends of a house are sometimes non-loadbearing and NZS 3604 currently allows single joists under the wall in this case. The wall bracing rating to cause joist failure for an exterior single joist with no 12 mm hole, based on the assumptions given in Section 10.1 and 10.2, is given in Table 5.

**Table 5. Maximum bracing rating for exterior (single) floor joists without a 12 mm hole**

(Bracing values shown are in units of BU's/m)

Floor joist size	Joist spacing (mm)		
	400	450	600
90 x 35	94	95	97
90 x 45	99	100	104
140 x 35	108	110	114
140 x 45	107	109	121
190 x 45	123	124	130
240 x 45	138	140	148
290 x 45	155	157	166

### 10.3.2 Interior single joists

Thurston (2007(a)), reported that the vertical load from the bracing is shared between 1.70 joists, but stated that this value may be too high.

Table 6 gives the maximum bracing rating assuming that the applied vertical load is shared between 1.5 joists, the wall is directly over the joist and parallel to it, and a 12 mm diameter hole is drilled in the joist. Table 7 is similar, but assumes no 12 mm hole in the joists.

**Table 6. Maximum bracing rating for wall directly above interior floor joists and parallel to the joist**

(Bracing values shown are in units of BU's/m)

Floor joist size	Joist spacing (mm)		
	400	450	600
90 x 35	88	89	92
90 x 45	96	97	101
140 x 35	99	101	106
140 x 45	102	104	119
190 x 45	116	117	124
240 x 45	130	131	140
290 x 45	144	147	157

**Table 7. Maximum bracing rating for wall on blocking between interior floor joists**

(Bracing values shown are in units of BU's/m)

Floor joist size	Joist spacing (mm)		
	400	450	600
90 x 35	103	104	107
90 x 45	110	111	116
140 x 35	121	124	131
140 x 45	120	122	140
190 x 45	141	143	151
240 x 45	162	164	175
290 x 45	184	187	200

Usually 90 mm deep joists are continuous over several spans. This will enhance the values for this depth joist given in Table 4 to Table 7. Thus, the maximum bracing ratings in the above tables are ignored for 90 mm deep joists in the evaluation of maximum bracing rating based on joist strength.

## 10.4 Maximum bracing rating to cause bearer failure

### 10.4.1 Wall parallel to bearer

Figure 12(a) shows the loading and Figure 12(c) shows the model used to determine maximum bearer bending moment. The bracing force B (BU's/m) can be in either horizontal direction, and so the absolute induced bending moments should be added to those produced by gravity loading.

Under racking load, as a wall starts to 'rock' it induces the following forces on the floor below.

- (a) A downwards compressive force, R, near the toe of the wall.



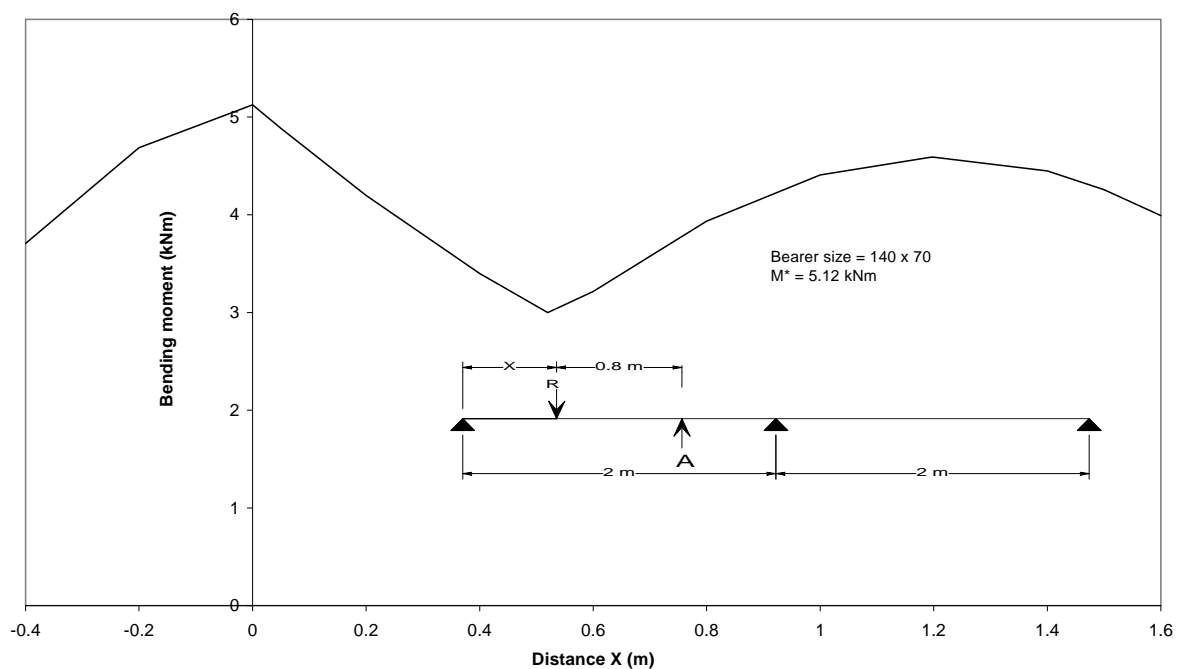
(b) An upwards tension force, A, at the wall base anchor.

The distance between the upwards and downwards forces noted in the calculations of (a) and (b) above is the distance 'D' in Figure 6 and Figure 12(c). It has been assumed that  $D/L = 0.9$ .

It is assumed that the wall end reactions are located directly over a timber joist as in this instance no blocking is needed. Blocking would otherwise distribute the vertical point loads from the wall over a length of bearer and this would be a less critical case.

The bracing rating for bearer bending failure was determined for the minimum sized bearer for each of the three bearer spans given in Table 6.6 of NZS 3604. This corresponds to the minimum bearer loaded dimension in this table.

The maximum bending moment on the bearer is a function of the location of the wall on the bearer. For each wall length and bearer length an influence line was used to determine the most critical location. A typical example is shown in Figure 13.



**Figure 13. Typical influence line of maximum bearer bending moment**

**The wall bracing rating to cause a bearer flexural failure as calculated above is given in**

Table 8 for the most critical wall location. It can be seen that values are moderately low. However, these values are expected to be generally conservative due to the following assumptions:

- The bearer size was chosen from the minimum loadbearing dimension (LD).
- The point loads shown in Figure 13 will be spread over a significant length, depending on the relative positions of end reactions/joists/blocking.
- Bearers are sometimes rough-sawn timber which is likely to have greater dimensions than the dressed sizes assumed.
- Bearers will often be from pairs of members rather than a single member and thus a K4 factor of 1.14 is applicable.
- The failure loads are for the worst case wall length and wall placement.

**Table 8. Maximum wall bracing rating (BU's/m) to exceed bearer theoretical flexural capacity**

Bearer Span	Wall parallel to bearer – bracing wall length (m)			Wall perpendicular to bearer
	0.8	1.6	2.4	
1.30	125	123	130	132
1.65	178	160	172	120
2.00	162	162	149	113

#### 10.4.2 Wall perpendicular to bearer

For construction where a bracing wall is perpendicular to the bearer (i.e. parallel to the joists) the most critical situation, with regard to bearer bending moments, is for construction having long bracing walls and short joists such that the compression end of the wall is directly over the bearer and the tension end is past the end of the joist. The bearer is then loaded with a single point load.

##### The lowest bracing rating in

Table 8 is 113 BU's/m for walls perpendicular to bearers where the bearers have a span of 2 m.

## 11. BLOCKING-TO-JOIST CONNECTION

The blocking-to-joist connection of two end nails specified in NZS 3604 is analysed in this section. From Figure 53 the pull-out strength of four nails at 4 mm slip = 6 kN. Therefore, the strength of the two-nail joint is taken as 3.0 kN. It is assumed that the wall uplift end reaction, from the wall anchor attached to the blocking, is located close to one joist so that the majority of the uplift force is transferred through a single connection. Add on ER, being the end continuity restraint, which Thurston (2007(b)) recommends to be 9 kN to give a total force = 12 kN. From Figure 6 and eqn. (1) the bracing rating corresponding to this uplift strength =  $20 \times 12 / H = 100$  BU's/m. If ER is less than 9 kN, as may be the case for internal walls without any wall returns, the maximum bracing rating will be lower. Any floor gravity loading will reduce the upward force and thus it is conservative to ignore it.

If a 6 kN blocking-to-joist proprietary connector is also used, then the maximum bracing rating increases to 150 BU's/m.

## 12. SEPARATION OF FLOOR MEMBERS AT FIRST FLOOR LEVEL

Figure 14 shows the construction and forces relevant for this failure analysis. Figure 54 of Phase III of this project (Thurston 2007(b)) shows an example of such a failure. The vertical uplift force at wall ends from wall bracing loads must be transferred from the top storey stud through to the bottom storey studs. Gravity loads will help prevent separation. The following connections must be able to transfer the forces, with the hand-driven nailing solution being the most critical (based on the measured nail pull-out strengths given in Appendix C):

- (1) Joist-to-wall upper top plate via three 90 x 3.15 power-driven skew or two 100 x 4 mm hand-driven skew nails (this failure mechanism is analysed in Section 13).

- (2) Upper storey wall bottom plate-to-joist below via a coach screw or through-bolt (proven by P21 test).
- (3) Lower storey wall upper top plate-to-wall lower top plate via three 90 x 3.15 power-driven nails or two 100 x 4 mm hand-driven nails every 500 mm centres.
- (4) Wall lower top plate-to-stud via two 90 x 3.15 power-driven or two 100 x 4 mm hand-driven end nails every stud. The wall sheathing also helps to hold the two together. However, failure of this connection was observed in Phase III, Stage II testing.

It is assumed that by the time the vertical load from the loaded floor joist is transferred to the framing below, that it is carried by two stud/plate connections or two sets of plate-to-plate connectors, and that the gravity load on 600 mm of floor (measured in a direction parallel to the bracing load) resists the upward movement.

Item (4) is the most critical if the effect of the sheathings is ignored. From Appendix C of this report the average joint strength =  $2 \times 2 \times 1.16 \text{ kN} = 4.64 \text{ kN}$ , for two stud-to-plate joints each consisting of two nails. It is assumed that the sheathings will in general add sufficient strength to make this less critical than item (3), although more work needs to be done to verify this. Thus, the joint strength is taken as  $2 \times 2 \times 1.25 \text{ kN}$  (from Table 14) = 5 kN. This must be factored by the materials reduction factor of 0.8 and the result is 4.0 kN.

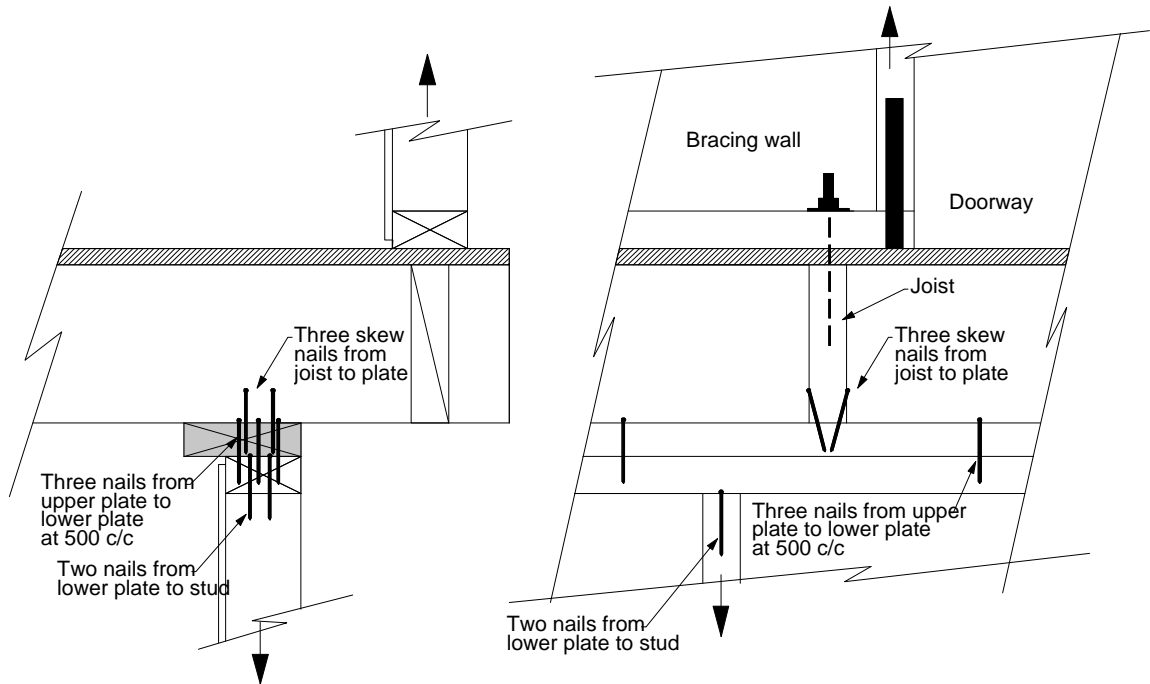
The gravity load on the joint is estimated as follows:

Floor: Assume joists are at 600 mm centres with a dead plus live load of 0.6 kPa. Assume a tributary area of 2.5 m x 0.6 m (i.e. a gravity load of 0.9 kN).

Wall self-weight: Assume  $0.4 \text{ kN/m} \times 1.2 = 0.48 \text{ kN}$ .

Roof and ceiling above: Assume this is below a gable end of a house with a roof and ceiling weight of 0.4 kPa and an effective loadbearing dimension of 1 m. Assume that as the floor lifts it attracts the load from a roof length of 1.2 m. Thus, assumed weight from roof and ceiling =  $0.4 \times 1 \times 1.2 = 0.48 \text{ kN}$ .

Total gravity load =  $0.9 + 0.48 + 0.48 = 1.86 \text{ kN}$ . Factor this by 0.9 and add on the joint strength of 4.0 kN. Also add on ER, being the end continuity restraint which Thurston (2007(b)) recommends to be ER = 9 kN. Total now = 14.67 kN. From Figure 6 and eqn. (1) the bracing rating corresponding to this uplift resistance =  $20 \times 14.67 / H = 122 \text{ BU's/m}$ .



**Figure 14. Cross-section of typical upper floor to lower connection using power-driven nails**

### 13. SEPARATION OF FLOOR JOISTS FROM PLATES AND BEARERS

The vertical uplift force at joist ends from wall bracing loads must be transferred to the framing below (i.e. the plate or bearer). Gravity loads will help prevent separation. The fixing is assumed to be two skewed 100 x 4 nails which is more critical than the power-driven nail option.

From Appendix C of this report the average joint strength is taken as  $2 \times 1.25 = 2.5$  kN. This is only approximate as the nails are skewed rather than straight-driven as tested in Appendix C. This is factored by the materials reduction factor of 0.8 and the result is 2.0 kN.

The gravity load (from Section 12) consists of the floor weight (0.9 kN) and the wall self-weight (0.48 kN). The roof and ceiling weight is not included as this is not applicable for interior situations.

The total gravity load is therefore 1.38 kN which is factored by 0.9. The joint strength of 2.0 kN is added. The end continuity restraint force, ER, must also be added. Thurston (2007(b)) recommends ER should be taken as 9 kN resulting in a total uplift resistance of 12.24 kN. From Figure 6 and eqn. (1) the bracing rating corresponding to this uplift strength is  $20 \times 12.24 / H = 102$  BU's/m.

## 14. MAXIMUM WALL BRACING RATING FROM FLOOR TESTS

### 14.1 Description and purpose of tests

There are many potential failure mechanisms in timber floor systems which may limit the transfer of end reaction forces from the bracing wall to the ground. Timber bearer and joist failures were considered separately in Section 10.

As size effects were important, it was considered that elemental tests and simplistic analysis were not appropriate and probably very conservative. The following actions were unlikely to be modelled realistically:

- the load sharing between joists
- the composite action of flooring and joists (this would influence load sharing and also strengthen the joist-to-blocking connections ), and
- the effect of the weight of the floor, walls, roof and ceiling.

A 3.6 m x 3.6 m floor was constructed and bracing tests performed on this floor as described in Appendix A.

The test floor was constructed on ordinary timber piles and had timber bearers, joists, blocking and flooring which complied with NZS 3604 (SNZ 1999). Racking tests were performed on walls located on both the edges and interior of the floor such as shown in Figure 15. Weights were added to the floor to simulate a 0.2 kPa floor live load and relatively low levels of axial load from walls and roof as discussed in Appendix A. Weights were initially added to the piles to simulate the volume of concrete required around 'ordinary piles' as stipulated in NZS 3604. When the piles uplifted they were anchored to the strong floor to enable greater bracing loads to be applied to the test walls, causing other failure mechanisms to develop.

The piles were not designed to carry horizontal load. Only vertical load transfer was of interest. Therefore, independent reaction frames were used at each corner to carry the horizontal load at the floor level.

### 14.2 Failure loads

The measured racking loads at which the piles lifted from the ground, bearers lifted off the piles, joists lifted off the bearers, and joists failed in flexure, were low. This was attributed to the test walls being single walls and therefore lacking the continuity restraint which adjacent construction would otherwise have provided. Section 14.3 explains how the test results were modified to take into account an assumed end restraint. Unmodified test results are summarised below.

#### 14.2.1 Load parallel to bearers

(a) Pile uplift and 4 skew nail pile-to-bearer connection failure

For construction where the pile was not anchored to the foundation and the pile-to-bearer connection was only 4 skew nails, the pile uplifted from the ground and the nails pulled out of the bearer-to-pile connection at the same applied bracing load:

- near a floor corner at a racking load of 4.8 kN (53 BU's/m)
- near mid-length of one side at a racking load of: 6.6 kN (73 BU's/m).

The pile was then anchored to the foundation and the pile-to-bearer connection replaced with two additional wire dogs plus two new skew nails (an option in NZS 3604).

(b) Joist-to-bearer connection failure

The failure occurred when the blocking, through which the wall hold-down anchor was fixed, lifted and pulled the adjacent joists off the bearer:

- near the mid-length of one side at a racking load of: 8.4 kN (93 BU's/m)
- near a corner at a racking load of 6.6 kN (73 BU's/m).

### 14.2.2 Load parallel to joists

(a) Pile uplift and joist-to-bearer connection failure

For construction where the pile was not held down and the pile-to-bearer connection was two wire dogs plus two skew nails (one option in NZS 3604), both the pile uplifted and the nails pulled out of the joist-to-bearer connection at the same time:

- at one corner at a racking load of: 5.6 kN (62 BU's/m)
- at another corner at a racking load of 6.4 kN (71 BU's/m).

The edge joist was then strapped to the bearer below.

(b) Blocking-to-joist connection failure

The blocking between joists to which the wall anchor was attached separated from the joists at 90 BU's/m.

(c) Bearer-to-pile connection failure (two wire dogs plus two skew nails)

Failure occurred at 90 BU's/m.

(d) Joist flexural failure

Joist flexural failure occurred at a racking load of 102 BU's/m.

This joist was drilled with a 12 mm hole. Without this hole the expected failure would have been at a racking load of 139 BU's/m.

### 14.3 Modification for end restraints

Only a single isolated bracing wall was tested. This was placed at the various locations shown in Figure 25. In a real building the adjacent construction would help resist a racking-induced uplift force. This is simulated in the BRANZ P21 test with a 'three-nail' uplift restraint (see Section 3.2) which has a strength of approximately 4.5 kN. Thurston (2007(a) and 2007(b)) showed that a 9 kN restraint was a better approximation for most situations. From Figure 6 and eqn. (1) an uplift end restraint, ER, will enable the bracing rating to increase by  $20 \times ER/H$  for the same anchorage force A. This equates to 37 and 74 BU's/m for an ER of 4.5 and 9 kN respectively.

Table 9 lists the bracing ratings at which failure occurred in the floor tests, modified for these values of ER.

**Table 9. Maximum bracing rating based on floor tests**

Units (BU's/m)

<b>Failure type</b>	<b>ER=0 kN</b>	<b>ER=4.5 kN</b>	<b>ER=9 kN</b>
Pile uplift	53	90	127
Pile-to-bearer Type 1	53	90	127
Pile-to-bearer Type 2	90	127	164
Joist-to-bearer	62	99	136
Joist flexural failure	102	139	176

**Legend:**

ER = end uplift restraint (see Figure 6)

Pile-to-bearer Type 1 connection is four skew nails

Pile-to-bearer Type 2 connection is two skew nails plus two wire dogs

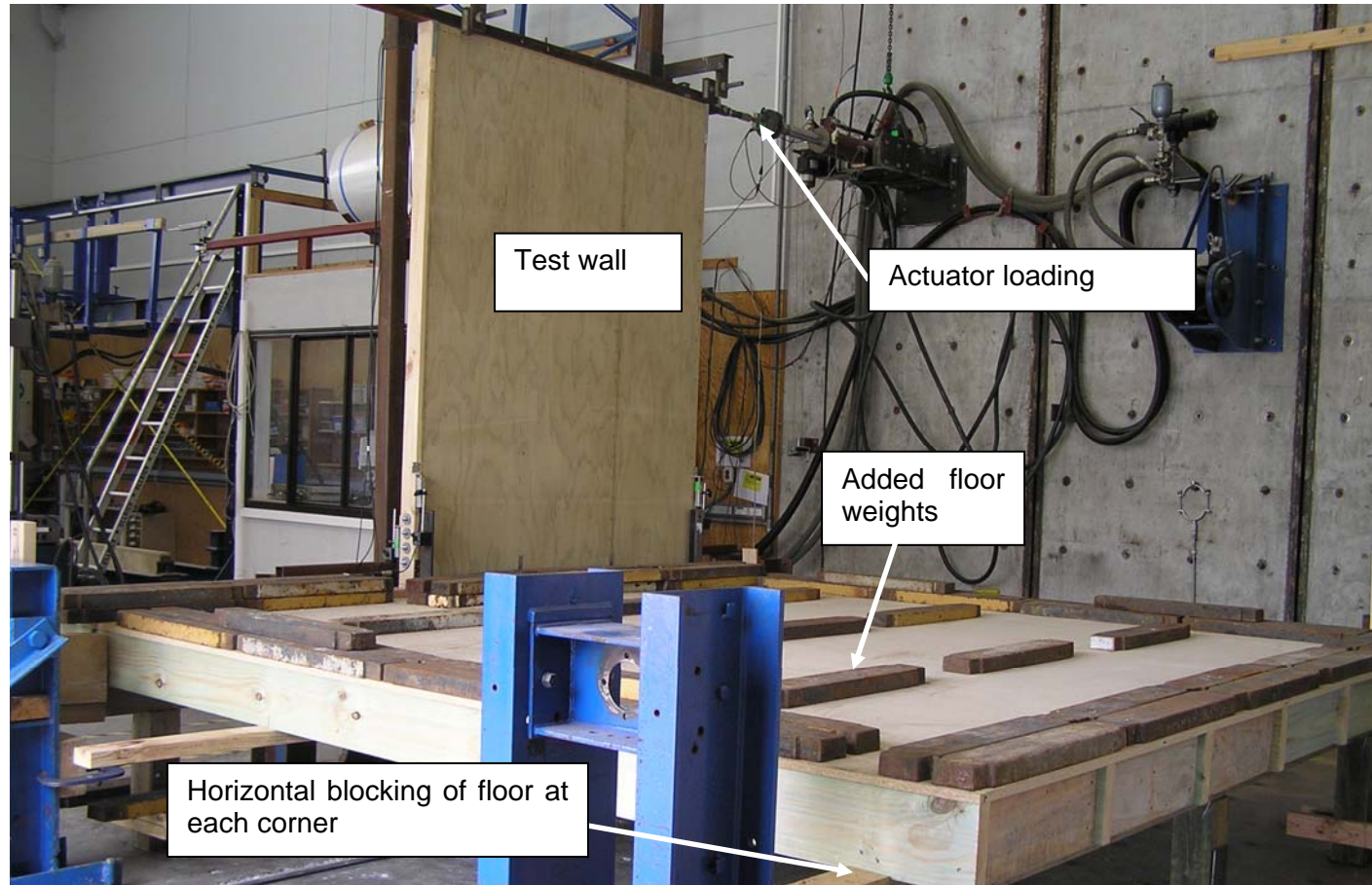


Figure 15. Typical flooring test

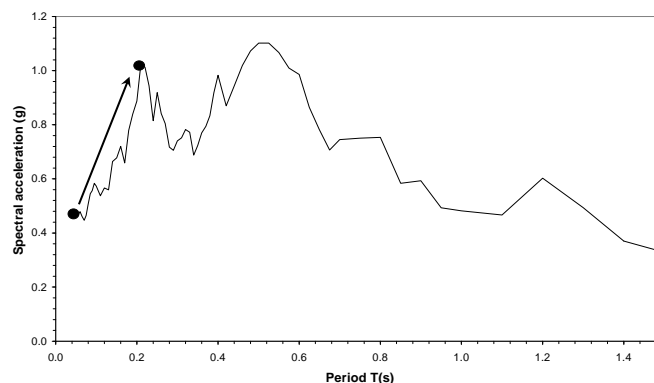


## 15. RECOMMENDED MAXIMUM WALL BRACING RATING FROM TOTAL PROJECT (PHASE I, II AND III)

### 15.1 Earthquake demand loading

The absence of major earthquakes in New Zealand, since the 1931 Hawkes Bay earthquake, means modern house construction has not been fully tested by a major event. However, generally New Zealand house wall systems have performed well in past earthquakes. Reasons for the good performance are discussed below:

- The earthquake design loads specified in NZS 3604 assume houses have a period of 0.4 seconds, 5% damping and use estimated house weights. Due to the stepwise nature of selecting house weights, actual weights are mostly expected to be less than assumed weights, actual damping is expected to be higher, and periods at low deflections expected to be lower (Thurston 2002, Fischer et al 2000). Thus, houses will attract less than the design seismic load in a design level event. However, the racking flexibility of walls tested in this investigation at high loads was far greater than measured in P21 tests due to the vertical flexibility of the timber foundations. This means that the house period may migrate to more critical periods at high loads, thereby attracting more seismic load as illustrated in Figure 16.



**Figure 16. Typical acceleration response spectrum showing increase in response of a house when flexibility increases**

- The small room sizes and excess of walls of many houses built in the past made the houses stronger than required by the standards.
- Houses lined with plasterboard on the interior, which have taped and stopped joints, are expected to be significantly stiffer and stronger than construction without such joints. This is discussed in detail in Section 7.1 of Thurston (2007(b)). This additional strength from 'systems effects' is also ignored in the current method of assessing house lateral strength.

Aspects discussed above suggest that it is inappropriate to apply maximum bracing limits that are too conservative as a measure to avoid foundation failures.

## 15.2 Considerations used for determining a maximum bracing limit

Recommending a maximum bracing rating, based on the work described herein, is subjective and the philosophy used is given below. Some failures may still occur in buildings designed to this limit in a design event if they have members or joints which have a strength less than average.

The method of deriving a maximum bracing rating from the test results, and theoretical calculations determined in this study, is summarised below:

- For ductile mechanisms, such as nail pull-out failure in timber joints, the values used were the unfactored bracing rating at which failure occurred in the tests. Failure is defined as the point at which a mechanism occurs where the mechanism effectively stops any greater bracing rating being achieved.
- Member flexural failures are a less desirable failure mechanism and these were based on the calculated member mean strength factored by a strength reduction factor of 0.8. As recommended by Walford (2007(b)), the mean strength was taken as twice the timber characteristic strength given in NZS 3603 (SNZ 1992). Members analysed were joists, bearers and wall bottom plates.
- Analysis was also used to predict joint failures. These were the average measured strength at 4 mm slip from elemental tests reported in the Appendices factored by 0.8. Gravity load (which enhanced joint strength) was calculated using tributary area of the floor plus a conservative estimate of the gravity load likely to be attracted to a lifting wall, both factored by 0.9 in accordance with AS/NZS 1170.0. These calculations are approximate, but do provide an estimate of theoretical failure strength.

The analysis and testing described in this project has assumed low axial loads on the bracing walls. Higher axial loads reduce net uplift forces on bracing walls. Hence, for loadbearing walls, particularly lower storey loadbearing walls, the bracing induced uplift forces considered in this study will be less than modelled and hence higher wall bracing loads than recommended herein to preclude uplift failures can be safely used. However, wall bracing loads causing joist and bearer failure are not expected to be influenced by this attracted axial load as the predicted failures occur under the compression toe rather than the uplift corner of the bracing wall and these are not influenced by the axial load attracted to the bracing wall uplift corner (refer to the theory in Section 6).

## 15.3 Maximum bracing rating for walls founded on timber floors

### 15.3.1 Comparison of measured and predicted member strengths

The full-scale room and floor test arrangements were designed to measure the actual strength of joints within full-scale construction. The construction tested did not have the most critical member size or geometry for member flexural failure. Some members did fail as discussed below. Of interest is the ratio of measured member strength to member characteristic strength, called the Over-Strength Factor (OSF) which is assumed to be 2.0 in the analysis given in this report (see Section 4). Values of OSF calculated when member failures occurred in the tests are given below:

- Joist failure in Phase I. OSF = 3.0. The calculated joist strength used the reduced joist section as the failure surface occurred through an M12 bolt-hole. This was in a zone of 'clears' – i.e. a zone of wood with no knots or grain irregularity.

- The strength of Joist J5 and a bearer in Phase II was measured separately after the Phase II testing had completed. They had OSFs of 2.43 and 2.60 respectively.
- Based on the measured uplift forces, bottom plates in Phase III failed at two locations with OSFs of 2.11 and 2.17.

### 15.3.2 Recommended maximum bracing loads for minimal changes to NZS 3604

Test results have shown that for normal construction, the effective vertical restraint at the ends of a bracing wall is 9 kN and this value was adopted in the theoretical calculations herein. A 9 kN continuity resistance to rocking at both ends of the wall element requires a bracing load of  $9 \times 20/H = 74$  BU's/m before any end reaction is induced. The test results from Phase I testing have been upgraded by 74 BU's/m to account for this end continuity which was not simulated in these tests.

In some locations (e.g. at free ends of an internal wall or at a full wall-height door opening) the continuity forces were found to be significantly lower than 9 kN. In such locations, higher uplift forces will be transmitted to the foundations and foundation failure is therefore more likely in a major event. It should also be noted that the high continuity resistance is dependent on taped and stopped plasterboard joints, or their equivalent, being used at both wall ends and wall-to-ceiling junctions. Without these joints the maximum bracing resistance derived in this study would need reducing by 37 or 74 BU's/m as discussed in Section 14.3.

The maximum bracing ratings derived in this study for each potential failure type are given in Table 10. The low value measured (100 BU's/m) for pile uplift is ignored as this mechanism is considered to result in only minor damage and may indeed be a desirable failure mechanism, acting much like base isolation.

Although the measured failure for the bearer-to-pile Type 1 (defined at the bottom of Table 10) connection, at 127 BU's/m, was significantly greater than some other mechanisms, the writer believes that the most critical situation was not tested and the maximum bracing rating determined may be unconservative. It is therefore recommended that the suggested change to NZS 3604 (SNZ 1999) given in Section 15.3.3(1) be adopted.

NZS 3604 requires 18 power-driven skewed nails per 1.5 m length (i.e. spacing of 83 mm) between a timber boundary joist and a plate on a masonry or concrete wall. The nails are intended to transfer horizontal loads from the timber joist to these strong walls. However, NZS 3604 is silent on the fixing required between boundary joists and a timber wall plate below. This is a serious omission and is discussed in Section 2.2 of Thurston (2007(b)). The lowest measured value of maximum bracing in Table 10 (70 BU's/m) was for construction where the boundary joist was fixed to the plate below at 600 mm centres. An option for fixing at 150 mm centres was also tested and gave a maximum bracing of 105 BU's/m, which is also a low value. It is therefore recommended that the suggested change to NZS 3604 given in Section 15.3.3(2) be adopted. Straps could alternatively be used to hold down the boundary joists. However, the shear load transfer would also need to be considered for this option.

Failure of the connection between blocking and floor joists was determined experimentally to have occurred at a bracing rating of 75 BU's/m. This is below the theoretical value of 100 BU's/m and this is attributed to the tested internal wall having no construction continuity at the ends (i.e. end restraint  $ER < 9$  kN). Excessive vertical movement was measured at blocking-to-joist connections, particularly under the internal wall of Phase III testing, but also in the other tests. The excessive vertical movement at the blocking caused excessive bracing wall flexibility. This made the internal wall of Phase III, Stage II ineffectual as a bracing element. It is therefore recommended that the suggested change to NZS 3604 given in Section 15.3.3(3) be

adopted. If each blocking piece is fixed to framing below with six skewed nails as specified in Table 7.6 of NZS 3604:1999, then blocking uplift strength (and hence wall rocking strength) would be significantly greater.

Some joist-to-plate connections failed at 95 BU's/m. Much of the wall flexibility in both Phase II and Phase III testing was attributed to joist uplift. It is therefore recommended that the suggested changes to NZS 3604 given in Section 15.3.3 (4) and (5) be adopted.

Calculations indicated that interior joists may fail in flexure if the wall above is racked to 99 BU's/m. It is therefore recommended that the suggested change to NZS 3604 given in Section 15.3.3(6) be adopted. Note, that for this situation the joists are drilled with a 12 mm anchor hole, whereas the anchors for walls located mid-way between joists will be into blocking, and thus the joists will be less likely to fail in bending. The additional wall stiffening due to the presence of the extra joist (as recommended) will also be of benefit as large wall deflections due to foundation flexibility were measured.

Calculations indicated that single exterior joists (with no 12 mm hole) may fail in flexure if the wall above is racked to 108 BU's/m. It is therefore recommended that the suggested change to NZS 3604 given in Section 15.3.3(7) be adopted.

Calculations indicated that bottom plates may fail in flexure at 105 BU's/m if the anchor bolt is 200 mm from the outside face of the wall end stud. It is therefore recommended that the suggested change to NZS 3604 given in Section 15.3.3(8) be adopted for situations where the hold-down bolt is at a greater distance than 150 mm from the outside stud.

Calculations indicated that separation of the nailed connection between wall top plates (where double top plates are used), and also the lower storey wall top plate connection to the lower storey stud, may theoretically occur at 122 BU's/m. In one test the plates separated at a room corner at 101 BU's/m and a stud separated from the above plate shortly afterwards. However, it is expected that in most circumstances the separation will not be too severe at 110 BU's/m.

Hence, if the suggested changes in Section 15.3.3 are adopted, then the recommended maximum bracing rating is **110 BU's/m** for construction on a timber foundation. This limit is expected to prevent foundation failures in most houses in a design earthquake or wind event. At higher bracing values, Table 10 lists other potential failure mechanisms (e.g. bearer failure at 113 BU's/m). Taking into account the inexact nature of the findings, variability in the field, the likelihood that strengthening one area would lead to a failure at slightly higher bracing rating at another, and the desirability for a reserve of strength, in the writer's opinion 110 BU's/m is an appropriate limit. It is a judgement call. The increased building cost associated with the proposed amendment of the current NZS 3604 must be balanced against the cost of damage in a major event and the cost/consequences of imposing various maximum bracing limits. For houses where there are insufficient wall length to meet bracing demands, specific design may be required.

In Phase III, Stage I testing which used full depth blocking between every pair of joists along external walls, joist roll-over deflection was a significant proportion of the horizontal deflection of the bracing walls in the storey above. Deflections greater than 45 mm (hence possibly leading to instability) were expected to occur at bracing ratings of 120 BU's/m. Instability is expected to occur at a lower bracing rating if blocking is discontinuous (as currently allowed by NZS 3604). It is therefore recommended that the suggested change to NZS 3604 given in Section 15.3.3(9) be adopted. The preferred solution is a 25 mm thick boundary joist with blocking used inside this where a hold-down bolt from a bracing wall is required. This blocking will then be approximately mid-width of the wall bottom plate.

Finally, the fixing of bottom plates to double joists using coach screws is an area of concern. The coach screws may be at the adjoining faces of the joists, particularly if the coach screw is placed at mid-width of the plate. Should this occur, the pull-out strength is expected to be compromised. It is recommended that coach screws only be fitted into solid timber. The methodology to achieve this in practice needs to be derived.

### **15.3.3 Required changes to NZS 3604 for a maximum bracing of 110 BU's/m to be appropriate**

- (1) The option for connecting bearers to normal piles with just four skew nails should be removed. This just leaves the option of two skew nails plus two wire dogs.
- (2) It is recommended that the minimum requirement for fixing boundary joists to the plate below be a single power-driven 90 x 3.15 mm skew nail at 100 mm centres from the joist-to-wall top plate along the length of the boundary joist – which will usually be placed from the outside as access is easier here. In addition, the joist end nailing of two hand-driven or three power-driven skew nails, as currently stipulated, should still be used.
- (3) Where a bracing wall is fixed to solid blocking between joists, and the blocking is not fixed to a plate bearer or stringer as specified in Table 7.5 of NZS 3604, then the blocking must be fixed to the joists at each end with a 6 kN connection.
- (4) Where joists run perpendicular to a bracing wall, both ends of the joists must be fixed to the plate or bearer below with a 6 kN connector if:
  - (a) The wall has a bracing rating greater than 80 BU's/m; and
  - (b) The bracing wall terminates within 300 mm of the joist.
- (5) Where joists run parallel to a bracing wall, both ends of the joist must be fixed to the plate or bearer below with a 6 kN connection if:
  - (a) The wall has a bracing rating greater than 80 BU's/m; and
  - (b) The wall line is within 300 mm of the joist line.
- (6) Where a bracing wall uses a bolt or coach screw hold-down into a floor joist, then double joists must be used if the wall bracing rating exceeds 80 BU's/m.
- (7) Where joists run parallel to an external bracing wall above then double joists must be used, irrespective of whether the wall is loadbearing or not.
- (8) Wall bracing ratings, where the hold-down bolt into a timber foundation is at a greater distance than 150 mm from the outside stud, should be limited to 90 BU's/m.
- (9) Where floor joists run perpendicular to an external wall above, and a boundary joist is not used, then full depth blocking shall be used within 300 mm of the external wall for the full length of the external wall.

**Table 10. Measured and theoretical maximum bracing ratings for walls constructed on timber floors**

<b>Action</b>	<b>Source</b>	<b>Basis</b>	<b>Maximum bracing rating</b>	<b>Comment</b>
Joist flexural failure	Phase I, Section 10.3.1	Theory	134 BU's/m	Exterior double joists with minimum depth 140 mm and M12 hole drilled in the joists.
	Phase I, Section 10.3.1	Theory	108 BU's/m	Exterior single joist with minimum depth 140 mm but no M12 hole drilled in the joists. N/A if item (7) is adopted.
	Phase I, Section 10.3.2	Theory	99 BU's/m	Interior single joist with minimum depth 140 mm and M12 hole drilled in the joist. N/A if item (6) is adopted.
	Phase I, Section 10.3.2	Theory	139 BU's/m	Interior joists with minimum depth 140 mm but no M12 hole.
Bearer flexural failure	Phase I, Section 10.4	Theory	113 BU's/m	
Bottom plate flexural failure	Phase I, Section 9.3	Theory	137 BU's/m	Bolt 100 mm from outside face of stud.
	Phase I, Section 9.3	Theory	105 BU's/m	Bolt 200 mm from outside face of stud. N/A if item (7) is adopted.
Separation of top plates/stud	Phase I, Section 12	Theory	122 BU's/m	
	Phase III, Section 7.3	Test	101 BU's/m	Occurred at one corner only
Getting load into wall	Phase I, Section 7.4	Theory	180 BU's/m	High value makes this action not critical.
Pile uplift	Phase I, Table 8 Phase II, Section 8.2	Test	127 BU's/m	Not critical should this action occur.
		Test	100 BU's/m	
Pile-to-bearer Type 1 connection	Phase I, Table 8	Test	127 BU's/m	This maximum bracing rating is considered to be unconservative as the most critical situation was not tested.
Pile-to-bearer Type 2	Phase I, Table 8	Test	164 BU's/m	High value makes this action not critical.
		Test	132 BU's/m	

Action	Source	Basis	Maximum bracing rating	Comment
connection	Phase II, Section 7.5			
Joist-to-bearer or Joist-to-plate connection	Phase I Section 13	Theory	102 BU's/m	Used two hand-driven nails whereas tests used three power driven nails.
	Phase I, Table 8	Test	136 BU's/m	
	Phase II, Section 8.2	Test	110 BU's/m	
	Phase III, Section 7.3	Test	95 BU's/m	
Blocking-to-joist connection	Phase I, Section 11	Theory	100 BU's/m	Anchor is located at one end of blocking.
	Phase II, Section 5.6	Test	139 BU's/m	Anchor mid-way between two ends of blocking.
	Phase III, Section 7.4	Test	75 BU's/m	Under internal wall which had no end uplift continuity.
Joist roll-over	Phase III, Section 7.4	Test	120 BU's/m	Would be lower if intermittent blocking was used.
Boundary joist fixing to top plate along length.	Phase III, Stage I	Test	70 BU's/m	Fixing is single skew nail at 600 mm centres.
	Phase III, Stage I	Test	110 BU's/m	Fixing is single skew nail at 150 mm centres.
	Phase III, Stage I	Test	95 BU's/m	Fixing is single skew nail at 600 mm centres.
	Phase III, Stage I	Test	105 BU's/m	Fixing is single skew nail at 150 mm centres.

Pile-to-bearer Type 1 connection is four skew nails

Pile-to-bearer Type 2 connection is two skew nails plus two wire dogs

#### 15.3.4 Other conclusions/recommendations

- (1) From the tests in both Phase II and Phase III, it was concluded that for walls with normal end continuity construction the vertical end restraint provided by adjacent construction was approximately 9 kN. If the wall terminated at a full wall height opening the end restraint was approximately 4.5 kN.
- (2) Tests were also done on internal walls with no end construction continuity although they had a plastered ceiling joint. The vertical end restraint provided by adjacent construction was found to be approximately 0 kN for internal walls on a 'soft' timber foundation. With a more rigid foundation, the lifting corner attracted large axial loads from the ceiling, which at high bracing loads had the same effect as assuming that this axial load was zero but that the end restraint was 9 kN.
- (3) 'Rocking' accounted for approximately 75% percent of the deflection of the external walls. Much of this was due to separation of floor joists from their supports. Adoption of the recommendations of Section 15.3.3 is expected to improve the wall stiffness significantly.
- (4) For the purpose of this exercise, 'systems effect factor' is defined as maximum building bracing strength divided by the sum of the P21 strengths of the component walls. This factor varied considerably in the different tests. Values are given below but are only valid for construction using plasterboard with paper-taped and stopped joints. The values are of interest in predicting total house bracing strength – which is another research topic. It is not relevant to the strength of foundations which is the topic of this study. However, as this information became available from the testing, it is summarised below. Note that where the maximum bracing loads were limited by the strength of the foundations, and the walls were well short of their ultimate strength at test completion, the apparent 'systems effect factor' was low but should be rejected as it is meaningless. All values are given below for completeness, but values from tests where maximum bracing rating was governed by foundation weakness should not be included in any average taken.
  - Internal wall in Phase II, Stage III testing. The 'systems effect factor' was 2.06. This wall had 1.3 m wide wall return at each end. This spread the vertical load to the foundations and attracted high axial load to resist 'rocking' action.
  - Internal walls in Phase III testing. The factor for internal wall was 0.83 in Stage II as the wall had no wall returns and was founded on blocking which was flexible under the vertical loads arising from bracing forces, and the joist connections had been weakened by the Stage I testing. The linings were lowly stressed. This result is therefore ignored. The factor in Stage III was 1.91. This wall was founded on a joist and the joist ends were fixed with two additional nails. The 'systems effect factor' was influenced by the high axial load attracted from the ceiling by the 'rocking' motion of this wall.
  - External walls in Phase II testing. The 'systems effect factor' in Stage I testing was only 1.0. This low value was attributable to one of the wall elements taking a disproportionate share of the applied load as it was located on a stiffer foundation than the other wall elements. The factor in Stage II testing was 1.18, although this was noted to be very conservative as the linings were lowly stressed. In Stage IV it was 1.44.
  - External wall in Phase III testing. The factors were 1.33 and 1.44 for End 1 (Stage II) and End 2 (Stage III) respectively, but the lining fixings on these walls did still not reach their ultimate shear connection strength. The factor



was only 0.82 for Stage I testing as foundation failure limited load transfer to the walls.

- (5) Wall deflections increased considerably due to foundation flexibility. Thus, walls founded on the more rigid parts of the foundation may consequently carry a disproportionate share of the racking load. This phenomenon has yet to be resolved.
- (6) For construction with double joists on a building exterior and single joists subsequently located at 600 mm centres, it is recommended that only 8% of the vertical load from the bracing wall on the joist may be assumed to be redistributed to adjacent joists. However, for internal walls supported by single joists, and at right angles to the joists, it was found that the vertical forces directed to one joist are in fact shared between 1.7 joists, although there was some evidence that this value may be too high and a value of 1.5 is recommended for specific design situations.
- (7) There is a risk that coach screws used to fix bracing wall bottom plates to double joists are at the adjoining faces of the joists, particularly if the coach screw is placed at mid-width of the plate. Should this occur, the pull-out strength is expected to be compromised. Methods to ensure these fixings are into solid timber needs to be addressed.
- (8) Various alternatives to solid timber floor joists are now commonly used in buildings. The strength of the fixing of bracing walls to these joists, and the connection strength of these joists to the structure below, is outside the scope of NZS 3604 and requires specific design. However, future NZS 3604 committees may choose to provide some guidance.

## 15.4 Maximum bracing rating for walls founded on concrete floors

It was shown in Section 8.4 that it is unlikely that concrete foundation slabs will fail in flexure due to vertical load transfer from wall bracing elements. A wide variety of anchor strengths are commercially available, some of which meet most realistic bracing demand loads.

From Table 10 two limits need consideration for walls constructed on concrete floors. To transfer the load into a bracing wall, a limit of 180 BU's/m was calculated. To avoid bottom plate failure a limit of 137 BU's/m was calculated for bottom plates bolted to the foundation at 100 mm from the outside face of the studs. This value will vary with the actual bracing wall hold-down system used.

No specific limit for the maximum wall bracing ratings for walls on concrete foundations is recommended herein. The Peer Review Committee for this project requested that a limit be proposed to the NZS 3604 Review Committee for concrete foundations formed using conventional formwork, and also for masonry block formwork, which would take into account the capacity of commercially available anchors. Table 3 gives some guidance.

To apply bracing ratings from a P21 test the concrete anchors substituted for the hold-down bolts used in the test must be shown to be adequate. It is recommended that this be done by proving that the concrete anchor strength is greater than the demand loading. A proposed methodology for achieving this is summarised below:

- The anchor strength is taken as the 'characteristic strength' based on tests. This is the lower five percentile strength without being factored by  $\phi$  (strength reduction factor). Many proprietary anchors are available, each with their own specific strengths. The data is readily available from the manufacturers directly. BRANZ has tested many and some typical strength ranges for the generic

anchor types are given in Table 3. With greater anchor embedment greater strengths are likely to be achievable. However, the close distance of the anchor to the edge of the foundation in exterior walls limits the maximum strength.

- The anchor demand loading is determined from the wall bracing rating using the procedures described in Section 6.2 with W2 (wall axial load) set to zero. This may be used for general situations. A more refined solution can be obtained for specific situations where W2 can be estimated.
- Sponsors of bracing systems for concrete floors must provide sufficient information to enable substitute anchors to be used. This may merely be a list of suitable alternative anchors or may be the required anchor strengths. Minimum concrete strength, anchor embedment depth and anchor edge distance must be specified. Such anchors must also provide the shear capacities specified in Clause 7.5.12 of NZS 3604.

It may be difficult to achieve high bracing ratings for internal walls if wall anchors are limited in depth to meet durability requirements and to ensure the DPC is not penetrated (see Section 8.3). It is recommended that Standards New Zealand revisit the requirements for fixing internal bracing walls to concrete slabs.

## 16. REFERENCES

Collins MJ. 1975. 'A Light Timber Frame Wall Bracing Test and Set of Performance Criteria'. *NZFS Reprint No. 942*. NZFS, Rotorua, New Zealand.

Cooney RC and Collins MJ. 1979 (revised 1982, 1987, 1988, 1990). 'A Wall Bracing Test and Evaluation Procedure'. *BRANZ Technical Paper P21*. BRANZ Ltd, Judgeford, New Zealand.

Fischer D, Filiatrault A, Folz B, Uang C and Seible F. 2000. 'Shake Table Tests of a Two-storey House'. *Structural Systems Research Report No. SSRP 2000/15*. Department of Structural Engineering, University of California, San Diego, USA.

Herbert PD and King AB. 1998. 'Racking Resistance of Bracing Walls in Low-rise Buildings Subject to Earthquake Attack'. *BRANZ Study Report 78*. BRANZ Ltd, Judgeford, Wellington.

King AB and Lim KYS. 1991. 'Supplement to P21: An Evaluation Method of P21 Test Results for Use with NZS 3604:1990'. *BRANZ Technical Recommendation TR 10*. BRANZ Ltd, Judgeford, New Zealand.

Park R and Gamble WL. 2000. *Reinforced Concrete Slabs*. John Wiley and Sons, Inc, New Zealand.

Shelton RH. 2004(a). 'Bottom Plate Anchors under NZS 3604:1999'. *BRANZ Study Report 125*. BRANZ Ltd, Judgeford, New Zealand.

Shelton RH. 2004(b). 'Diaphragms for Timber Framed Buildings'. *Structural Engineering Society of New Zealand 17(3)*.

Standards Australia/Standards New Zealand. 2002. *AS/NZS 1170.0 Structural design actions. Part 0: General principles*. SA (Canberra, Australia), SNZ (Wellington, New Zealand).

Standards New Zealand. 1992. *NZS 4203 General structural design and design loadings for buildings*. SNZ, Wellington, New Zealand.

Standards New Zealand. 1999. *NZS 3604 Timber framed buildings*. SNZ, Wellington, New Zealand.

- Standards New Zealand. 2004. *Structural design actions Part 5: Earthquake actions – New Zealand Version 2. Draft New Zealand Standard DZ 1170.5:2004, Ballot Draft V2*. SNZ, Wellington, New Zealand.
- Stewart WG. 1987. *The Seismic Design of Shear Walls*. PhD Thesis, Department of Civil Engineering, University of Canterbury, New Zealand.
- Thurston SJ and Flack PF. 1980. 'Cyclic Load Performance of Timber Sheathed Bracing Walls'. *Ministry of Works and Development Central Laboratories Report 5-80/10*. MoW, Wellington, New Zealand.
- Thurston SJ and King AB. 1992. 'Bracing Requirements for NZS 3604 (1990) Limit State Code'. *Trans. Inst. Of Prof. Eng. New Zealand* 19(1)CE: November.
- Thurston SJ. 1993. 'Report on Racking Resistance of Long Sheathed Timber Framed Walls with Openings'. *BRANZ Study Report 54*. BRANZ Ltd, Judgeford, New Zealand.
- Thurston SJ and Park SG. 2004. 'Seismic Design of New Zealand Houses'. *Bulletin of the NZSEE* 37(1): March.
- Thurston SJ. 2003. 'Full-sized House Cyclic Racking Test'. *BRANZ Study Report 119*. BRANZ Ltd, Judgeford, New Zealand.
- Thurston SJ. 2007(a). 'Maximum Wall Bracing Rating that is Compatible with NZS 3604 Construction. Phase II: Testing of Room 1'. *BRANZ Study Report 163*, BRANZ Ltd, Judgeford, New Zealand.
- Thurston SJ. 2007(b). 'Maximum Wall Bracing Rating that is Compatible with NZS 3604 Construction. Phase III: Testing of Room 2'. *BRANZ Study Report 164*, BRANZ Ltd, Judgeford, New Zealand.
- Walford B. 2006. Private communication between the author and Bryan Walford of Scion, Rotorua, New Zealand.
- Winstone Wallboards Ltd. 2006. *GIB® Bracing Systems*. Proprietary publication of wall bracing systems published by Winstone Wallboards Ltd, Auckland, New Zealand.

# APPENDIX A. FLOOR TESTS

## A.1 Introduction

A floor was constructed as shown in Figure 21 to Figure 23 using details complying with NZS 3604. The floor was constructed on ordinary piles with timber bearers, joists, blocking and flooring which complied with NZS 3604 (SNZ 1999). A detailed description is given in Section A.2. Weights were added to the floor and piles as discussed in Section A.3.

A 1.845 m long strong stiff plywood wall was also constructed. This used a steel anchorage system attached to the end studs and bottom plate which enabled the wall to be simply bolted to the timber foundations.

The wall was first separately racked on a rigid foundation to enable wall flexibility when founded on a fixed base to be compared with wall flexibility when founded on the floor. Racking tests were then performed on the wall located on the floor edges and interior as shown in Figure 15 as follows: The wall was bolted in place at Location L1 on the floor (shown in Figure 25) and the wall racking load at foundation failure measured. It was then moved to Locations L2, L3 and L4 respectively and racked again to determine the bracing rating corresponding to foundation failures at these locations. The imposed racking loading from the wall is assumed herein to be an uplift force at the bolt at 100 mm from the wall outside at one end and a compression force taken to be at mid-stud width at the other end. The shear load transfer was not of significance in this study.

Initially there was no nailing between the bottom plate and the floor. However, after test L2A (see Section A.6.2), two 100 x 4 nails were added between wall and floor at each of the two middle studs. This nailing was expected to reduce the anchorage tension force, but increase the compression force at the other end of the bracing panel.

The piles were not braced and therefore not designed to carry horizontal load. Only vertical load transfer was of interest. Therefore the floor was blocked at each corner to carry this horizontal load as shown in Figure 15.

## A.2 Floor description

The total floor area was 3.69 m x 3.69 m. Flooring was 20 mm particleboard which was fixed to sub-framing with 60 x 2.8 mm ring shank galvanised nails at 150 mm centres around the sheet edges and 300 mm centres to intermediate supports as per Table 7.5 of NZS 3604.

The following components were used to construct the floor:

- Six timber piles of actual size 125 x 125 (refer to NZS 3604 Figure 6.2). The pile height (0.495 m) was chosen to suit the actuator height.
- Two 3.69 m long bearers each consisting of two beams of nominal size 125 x 50 mm.
- On Side 1 (see Figure 24) of the floor, the piles were fixed to bearers with four power-driven 90 x 3.15 nails placed on a skew angle.
- On Side 3 of the floor, the piles were fixed to bearers with two 4 mm diameter wire dog plus two 90 x 3.15 power-driven nails placed on a skew angle (as noted in Section 6.5.2(b) of NZS 3604).
- Eight joists of nominal size 200 x 50 mm and total length 3.69 m. Joists were at a spacing of 600 mm, except that one outside joist was spaced at 578 mm (see

Figure 21). They were fixed to the bearers with three skewed power-driven 90 x 3.15 nails as per NZS 3604 Table 7.5 (two one side and one the other).

- Continuous blocking between joists near joist mid-span and at joist ends.
- Intermittent blocking between joists on Side 1 only along the pile line as shown in Figure 21.
- Blocking was fixed to each joist with two end nailed power-driven 90 x 3.15 nails at one end and four power-driven 90 x 3.15 nails placed skewed at the other. Where blocking was above bearers, it was also fixed to the bearers using six power-driven 90 x 3.15 nails placed at a skew angle.

### **A.3 Added floor weights**

Weights were spread uniformly across the floor to simulate 0.2 kPa floor live load (i.e. a total of  $3.69 \times 3.69 \times 0.2 = 2.72$  kN) as shown in Figure 24.

A weight of 0.8 kN/m was also placed along Side 2, Side 3 and Side 4. This was calculated from:

- a non-loadbearing wall of weight of 0.4 kN/m
- a roof and ceiling contribution of 0.4 kN/m.

Side 1 was considered to be a loadbearing wall. When testing Side 1, the contributing roof weight was assumed to be 1.2 kN/m.

A 0.6 kN weight was initially added to each pile to simulate the volume of concrete required around 'ordinary piles' as stipulated in NZS 3604. This was based on a pile concrete depth of 200 mm (from Section 6.4.5.4 of NZS 3604) and a plan dimension of 400 mm (from Table 6.1 of NZS 3604). When the piles uplifted during the testing they were anchored to the strong floor to enable other failure mechanisms to develop.

### **A.4 Out-of-plane wall bracing**

The top of the test wall was braced in the out-of-plane direction to simulate the action of the horizontal roof diaphragm as shown in Figure 15. This was done using rollers to prevent any in-plane force from being imposed.

### **A.5 Test sequence**

The 1.8 m long test wall was fixed to the floor at four different locations, referred to as L1, L2, L3 and L4 as shown in Figure 25. At each location the wall was subjected to a single cycle to the following racking forces 50, 75, 100, 125, 150 ... etc. BU's/m until one element of the sub-floor failed (note that 20 BU's = 1 kN). The element that failed was then strengthened and the previous load cycle was then repeated before the same loading regime was continued.

### **A.6 Measurement of wall uplift tension force**

The wall hold-down anchor force was measured in each test with a load cell, as shown in Figure 17. The datalogger recording commenced with the anchor bolt not tightened to enable the degree of pre-load to be measured. Racking commenced when the bolt was tightened to approximately 5 kN, which was easy to apply using a 150 mm long spanner.

The bracing wall was 2420 mm high and 1845 mm wide. The distance between the compression block at one end of the wall to the anchor at the other end was  $1.845 - 0.075 - 0.022 = 1.748$  m. Hence, for a bracing force, F, the expected anchor force, A, is given by  $A = 2420/1748F = 1.38F$ .

Consider a pre-load of magnitude  $P_0$  in the anchor when the uplift force on the end stud,  $T$ , shown in Figure 17 is zero. The load cell force  $LC$  will therefore also be  $= P_0$ . The elastic compression of the timber  $= P_0 \times Kw$  where  $Kw$  is the timber spring coefficient. Now apply a tension force  $T$  to the angle. The change of force in the anchor within the timber  $= (T-P_0)$ . If the steel anchor spring coefficient  $= Ks$ , then its extension within the timber is given by  $(T-P_0)/Ks$ . The clamping compression in the timber will only be lost when the extension of the bar within the timber equals the initial clamping shortening of the wood i.e:

$$(T - P_0)/Ks = P_0/Kw \text{ or } T = P_0(1+Ks/Kw)$$

At this stage  $T = LC$  and  $P = 0$ .

As  $T$  is increased from zero to this limit, the value of timber compression  $P$  decreases.

Figure 18 shows the expected plots of  $LC$  versus  $T$  as a bracing test progresses. A typical result from the racking tests (from Location L1) is shown in Figure 19, but  $T$  has been replaced by the bracing force  $F$ . As expected the curve approaches a line where  $LC = 1.38F$ , which adds credence to the theory for predicting the anchor force from the bracing force.

Figure 20 shows a similar plot to Figure 18 but for Test L3. There were two differences for Test L3. The first was that the bolts were only done up finger tight and hence the pre-compression was negligible. The other was that the bottom plate was also nailed with two 100 x 4 flat-head nails near both middle studs. As expected this decreased the measured anchor force from the  $LC = 1.38F$  line as some of the uplift force was taken by these nails.

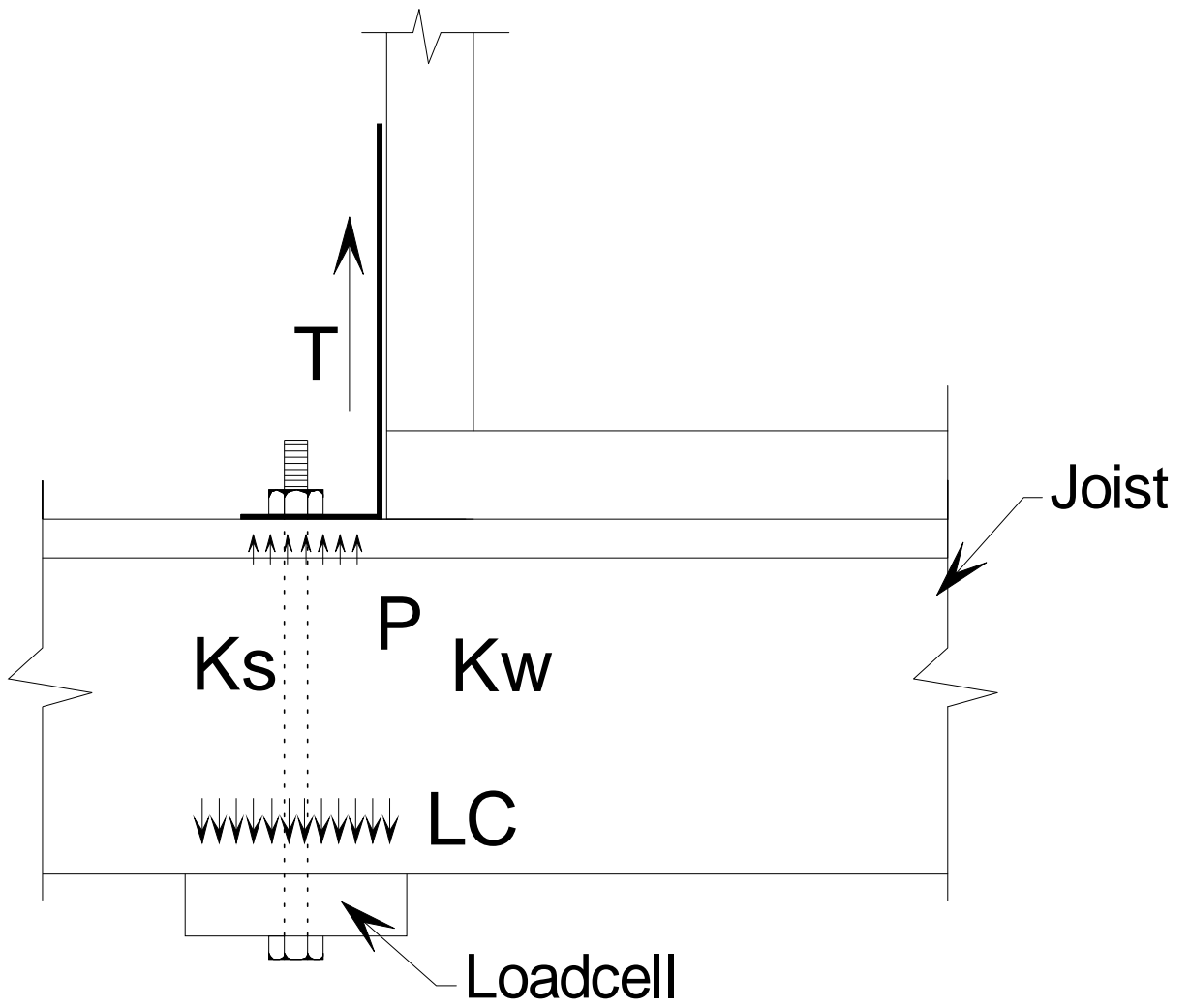


Figure 17. Pre-load of anchor bar and subsequent forces when angle pulled in tension

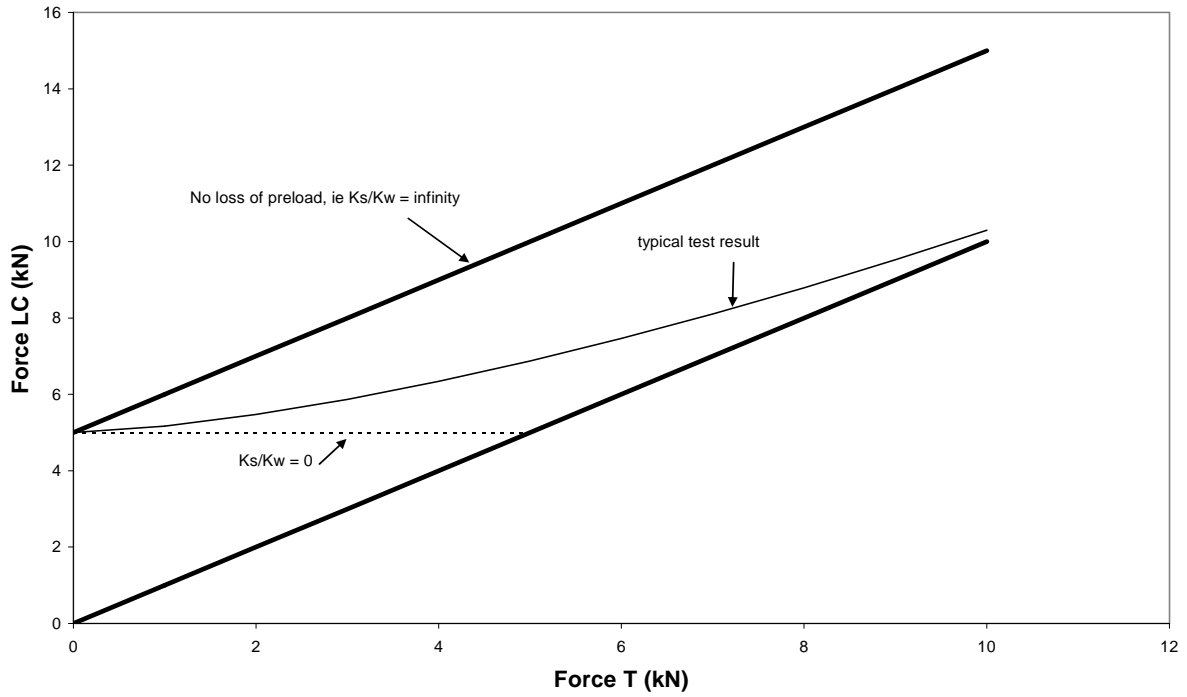


Figure 18. Expected plot of measured force and applied force

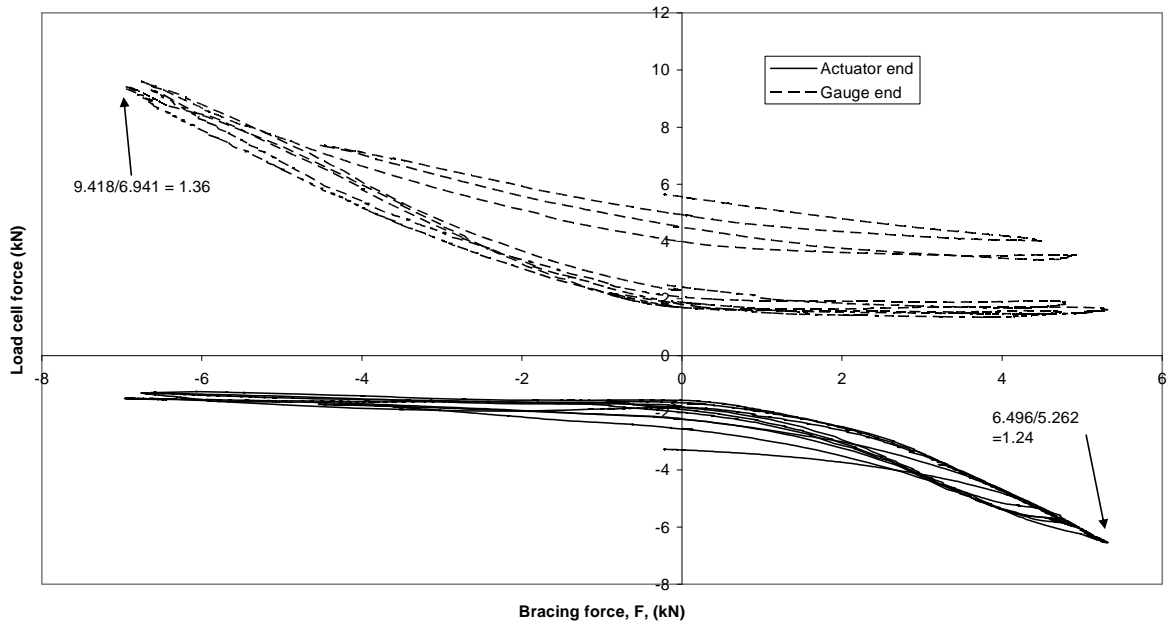


Figure 19. Forces in load cell in Test L1



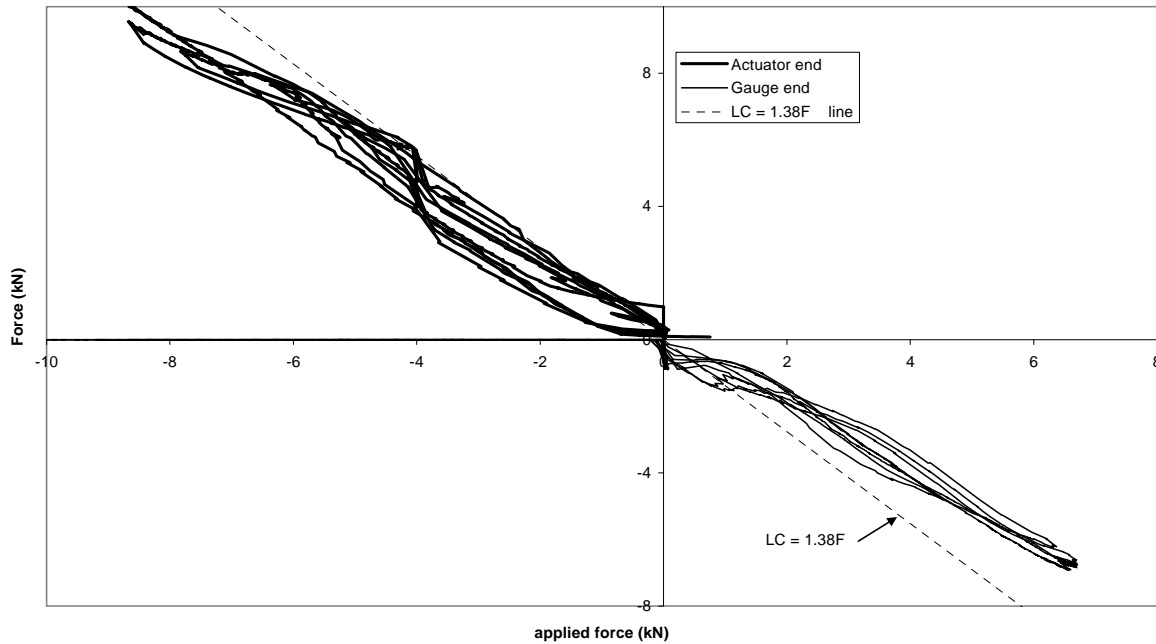


Figure 20. Forces in load cell in Test L3

## A.7 Test results

Test results are given below for each test location in turn.

### A.7.1 Location L1 (see Figure 25)

The racked wall was located on Side 1 of the floor with one end of the wall at 300 mm from the end of the floor. The holding down bolts were located 70 mm from the end of the wall. Thus, the wall uplift force was near mid-span of the blocking at both ends of the wall. Blocking along the pile line was at approximately 1800 mm centres. NZS 3604 does not require this blocking (see NZS 3604 Section 7.1.2.1), but it was used to ensure that the horizontal shear force could be transferred to the bearer above the pile. However, Location L3 omitted this blocking and the joist-to-bearer nailing strength proved adequate to transfer the horizontal forces without observable slip.

This test series was performed in three stages – called Test 1A, Test 1B and Test 1C respectively. Each stage resulted in a failure of one of the foundation connections. These connections were then strengthened to enable greater load to be applied in the next stage. The force versus deflection hysteresis loops for Test L1A and Test L1B are given in Figure 32 and the hysteresis loops for Test L1C are given in Figure 33. Also shown in these plots is the backbone curve from the racking tests of the wall when founded on a solid foundation, which on these plots is close to a straight line. These backbone curves are, in all instances, far stiffer than the test results on the floor showing that rotation of the wall due to vertical movement of the floor accounted for most of the wall horizontal movement. All curves have been corrected for bottom plate slip relative to the ground.

Table 11 summarises the test results for Location L1. Hysteresis loops for each phase in the testing are referred to in the table.

Table 11. Test results at Location L1

<b><u>Test Loading:</u></b>	<b><u>Observations</u></b>
<b><u>Hysteresis Loops of Figure 32</u></b>	
<b>Test L1A</b> Pile not bolted down	
Push wall to 4.5 kN (16 mm wall deflection)	Pile1 uplift from ground: 1.5 mm. Bearer uplift from pile: 2 mm.
Pull wall to 4.5 kN (13 mm wall deflection)	Pile2 uplift from ground: 0 mm. Bearer uplift from pile: 2 mm.
Push wall to 4.8 kN (27 mm wall deflection)	Pile1 uplift from ground: 7 mm. Bearer uplift from pile: 3 mm.
Pull wall to 6.6 kN (28 mm wall deflection)	Pile2 uplift from ground: 5 mm. Bearer uplift from pile: 2 mm.
Another push and pull to same loads	Similar wall deflections and uplifts
<b>Test L1B</b>	
Pile screwed down and another cycle to similar wall deflections performed.	Only a slight increase in resisted load. Pile uplift was zero. The bearer lifted from Pile1 by 10 mm in the push direction and the bearer lifted from Pile2 by 8 mm in the pull direction.
<b><u>Hysteresis Loops of Figure 33</u></b>	
<b>Test L1C</b> Two wire dogs added to pile-to-bearer connections.	
Push wall to 6.6 kN (22 mm wall deflection)	Bearer uplift from pile: 0.7 mm. The loaded blocking lifted in tension which pulled the joists off the bearer by 3 mm.
Pull wall to 6.6 kN (20 mm wall deflection)	Bearer uplift from pile: 1.6 mm. The loaded blocking lifted in tension which pulled the joists off the bearer by 3 mm.
Push wall to 7.4 kN (31 mm wall deflection) Refer photograph in Figure 27	Bearer uplift from pile: 2.8 mm. The loaded blocking lifted in tension which pulled the nearby joist off the bearer by 8 mm.
Pull wall to 8.4 kN (33 mm wall deflection) Refer photographs in Figure 28 to Figure 31.	Bearer uplift from pile: 3.0 mm. The loaded blocking lifted in tension which pulled the nearby joist off the bearer by 9 mm.

#### **A.7.2 Location L2 (see Figure 25)**

Table 12. Test results at Location L2 summarises the results at Location L2 on Side 2. One end of the wall was located at 300 mm from the end of the floor. The holding down bolts were located 75 mm from the ends of the wall. Figure 38 shows the assumed loading regime on the floor. The wall downward force was 300 mm from mid-span of the joists. Wire dogs had been used to increase the fixing from the bearer to Pile3. Pile 6 had already been fixed to the pile with Wire dogs in tests at Location L1.

Table 12. Test results at Location L2

<u>Test Loading:</u>	<u>Observations</u>
<b><u>Hysteresis Loops of Figure 36</u></b>	
<b>Test L2A</b> Piles already fixed to bearers with wire dogs	No uplift noted.
Push wall to ±4.5 kN (±16 mm wall deflection)	Pile3 uplift from ground: 5 mm.
Push wall to 6.4 kN (37 mm wall deflection). See photograph in Figure 34	Joist lifted from the bearer: 7 mm.
Pull wall to 5.6 kN (27 mm wall deflection)	Pile6 uplift from ground: 11 mm.
Another push and pull to same loads/deflections	Joist lifted from the bearer: 9 mm. Joist deflections monitored.
<b><u>Hysteresis Loops of Figure 37</u></b>	
<b>Test L2B</b> Two 100 x 4 nails were added between wall and floor at each of the two middle studs. Such nailing was used in all subsequent tests. Two wire dogs were used to increase the fixing from the exterior joist to the bearers and the piles were fixed to the strong floor to prevent pile uplift. Figure 37 compares the hysteresis loops from Figure 36 with this new construction.	
Push wall to 9.2 kN (38 mm wall deflection).	Blocking between joists separated 6 mm from the joists.
Pull wall to 8.1 kN (38 mm wall deflection)	Joists lifted off the bearer by 7 mm despite the newly placed wire dogs.
Another cycle to this deflection was performed. On the next push cycle at a load of 9.15 kN the joist failed in flexure at the through-bolt as shown in Figure 35.	Joists lifted the flooring from the blocking by 4 mm.
	Blocking between joists separated 7 mm from the joists.
	Joists lifted off the bearer by 5 mm despite the newly placed wire dogs.
	Bearer lifted off the pile by 6 mm despite the wire dogs.

The load cells under the wall were removed and replaced with 50 x 50 x 3 washers. After the hold-down bolts were tightened the racking cycling to the previous deflections was repeated. There was no discernable difference in the hysteresis loops. The washer had embedded slightly from the bolt tightening, but this did not increase in the subsequent racking test.

As noted in Table 12, a joist failed in flexure in Test L2. The predicted failure strength of this joist from NZS 3603 (see Section 10.4.1) from its measured size and assumed strength of 14 MPa was  $14 \times (45-12) \times 188^2/6 \times 10^{-6} = 2.72 \text{ kNm}$  at the 12 mm diameter hole location. The maximum applied bending moment of 8.48 kNm from Figure 38 resulted in an over-strength factor of  $8.48/2.72 = 3.25$ . If the load sharing factor of 1.08

is taken into account, the over-strength factor due to composite action and the difference between the actual failure flexural strength of the joist and the characteristic strength given in NZS 3603 is 3.0. It should be noted that the failure of the joist occurred in effectively a zone of clear wood (no knots or grain irregularity).

#### **A.7.3 Location L3 (see Figure 25)**

One end of the wall was located 300 mm from the end of Side 3. There was no blocking along the pile line. The overall test arrangement is shown in Figure 40 and the hysteresis loops are shown in Figure 39.

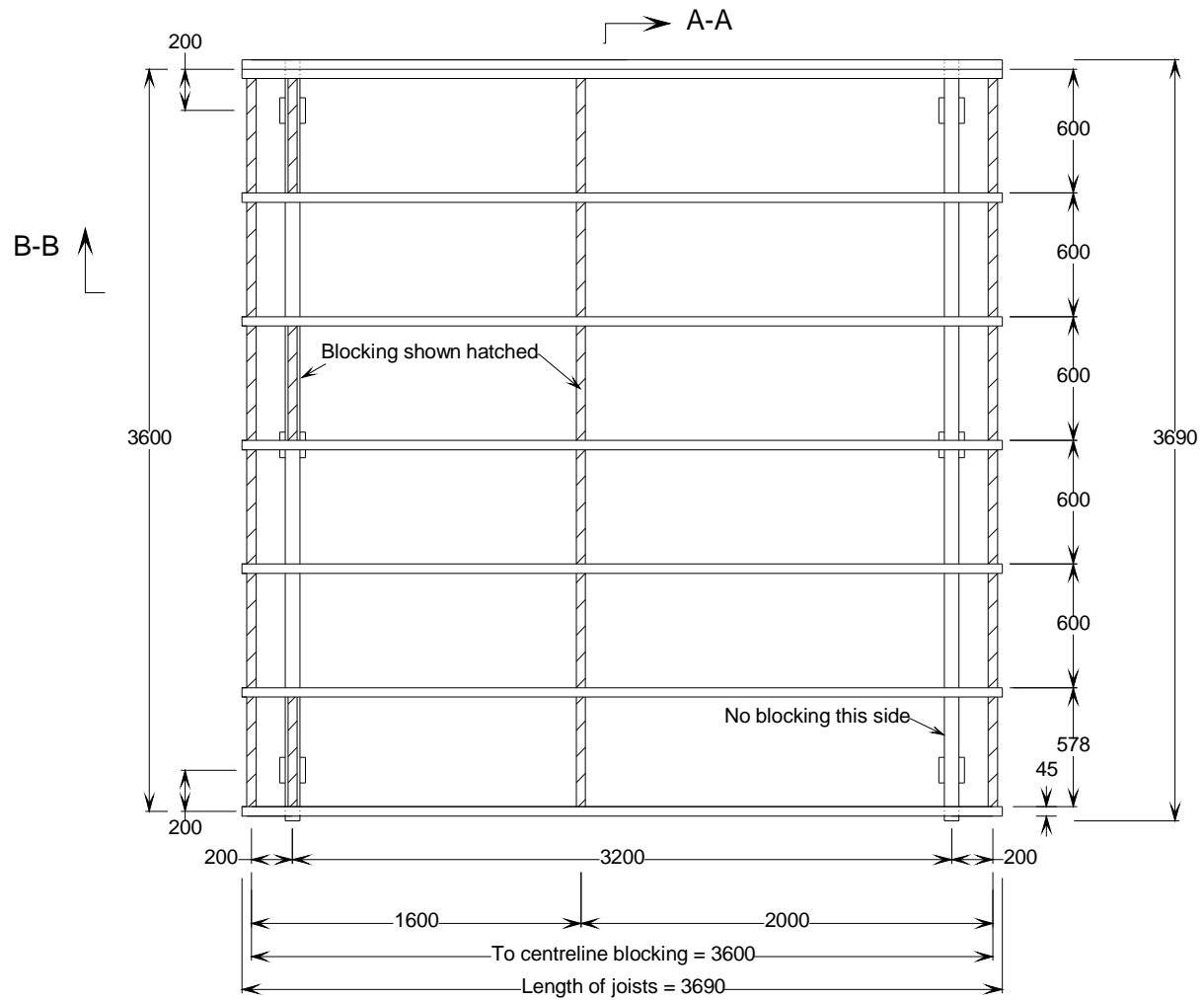
As the piles were connected to the bearer by wire dogs, there was little vertical movement between the two. Most of the uplift occurred as the nails pulled out of the joist-to-bearer connection as shown in Figure 41. Gaps occurred between the blocking and joists on the floor edge and the floor distorted as shown in Figure 42. The peak loads resisted were 8.66 kN push and 6.64 kN pull, with the pull being apparently more critical as the wall upwards load occurred near the end pile, whereas the push upwards load occurred near the middle pile. Despite the nails pulling out of the joists, the wall shear load transferred from the joists to bearer without discernable horizontal slip.

#### **A.7.4 Location L4 (see Figure 25)**

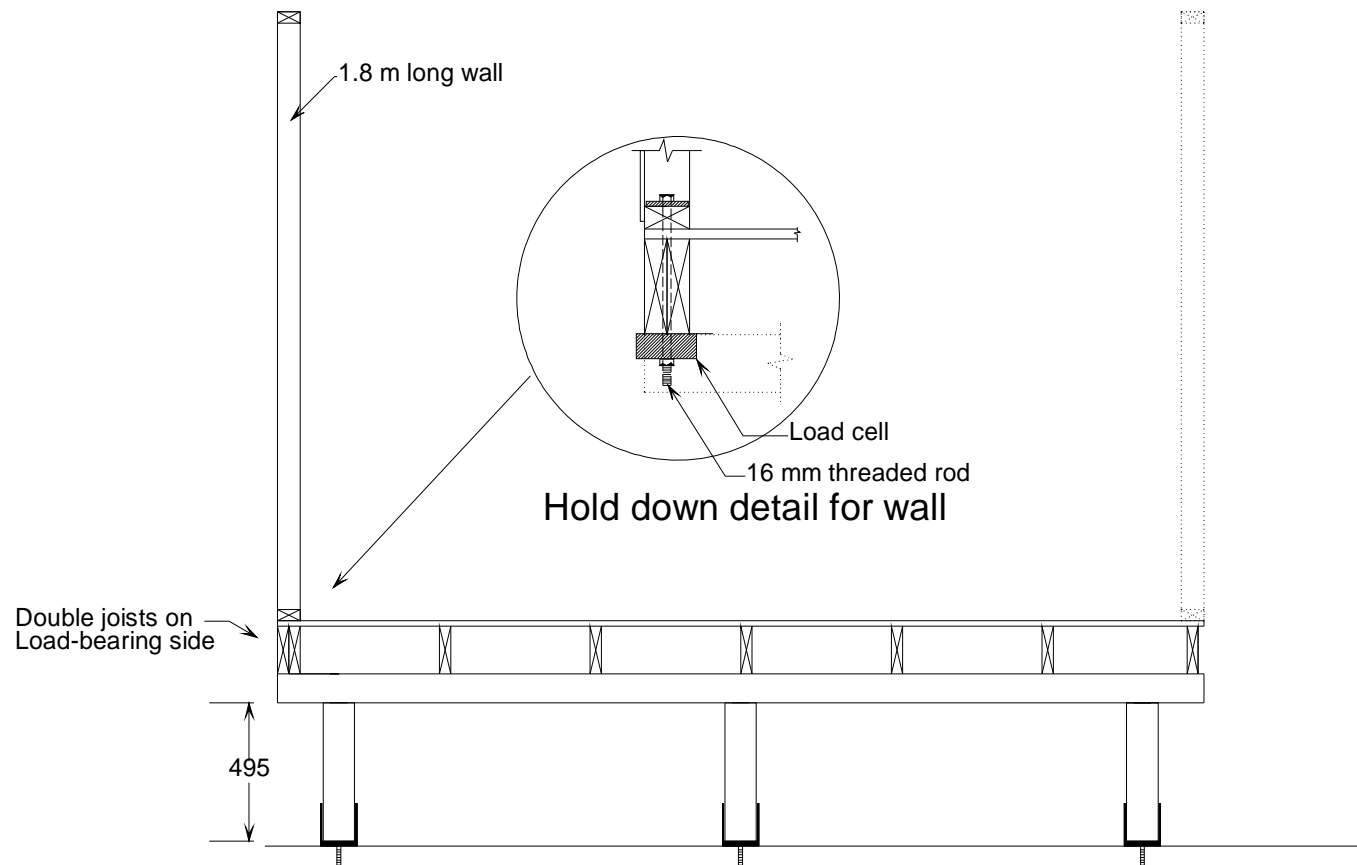
The wall was located above and at mid-length of the blocking near the joist mid-span. The wall anchor bolts fixed the wall to the blocking approximately mid-way between joists. The two joists bounding this anchor bolt at one end, plus the two at the other end are referred to as the 'critical joists'. Figure 44 gives the overall test arrangement and hysteresis loops are shown in Figure 43.

The hysteresis loops show close to a linear relationship between load and wall deflection, with the wall deflection being almost eight times that on a solid foundation at the same load. The main source of wall deflection was the vertical deflection of the 'critical joists'. During the last load cycle these joists deflected an average of 35 mm between the peak push and peak pull loads. As noted in Section A.6, the effective distance between the compression and tension force on the wall is 1748 mm. Thus, the joist deflection accounted for  $2420/1748 \times 35 = 48$  mm of the wall horizontal deflection. During subsequent disassembly of the floor it was noted that one joist had fractured and it was considered likely that this occurred during this loading.

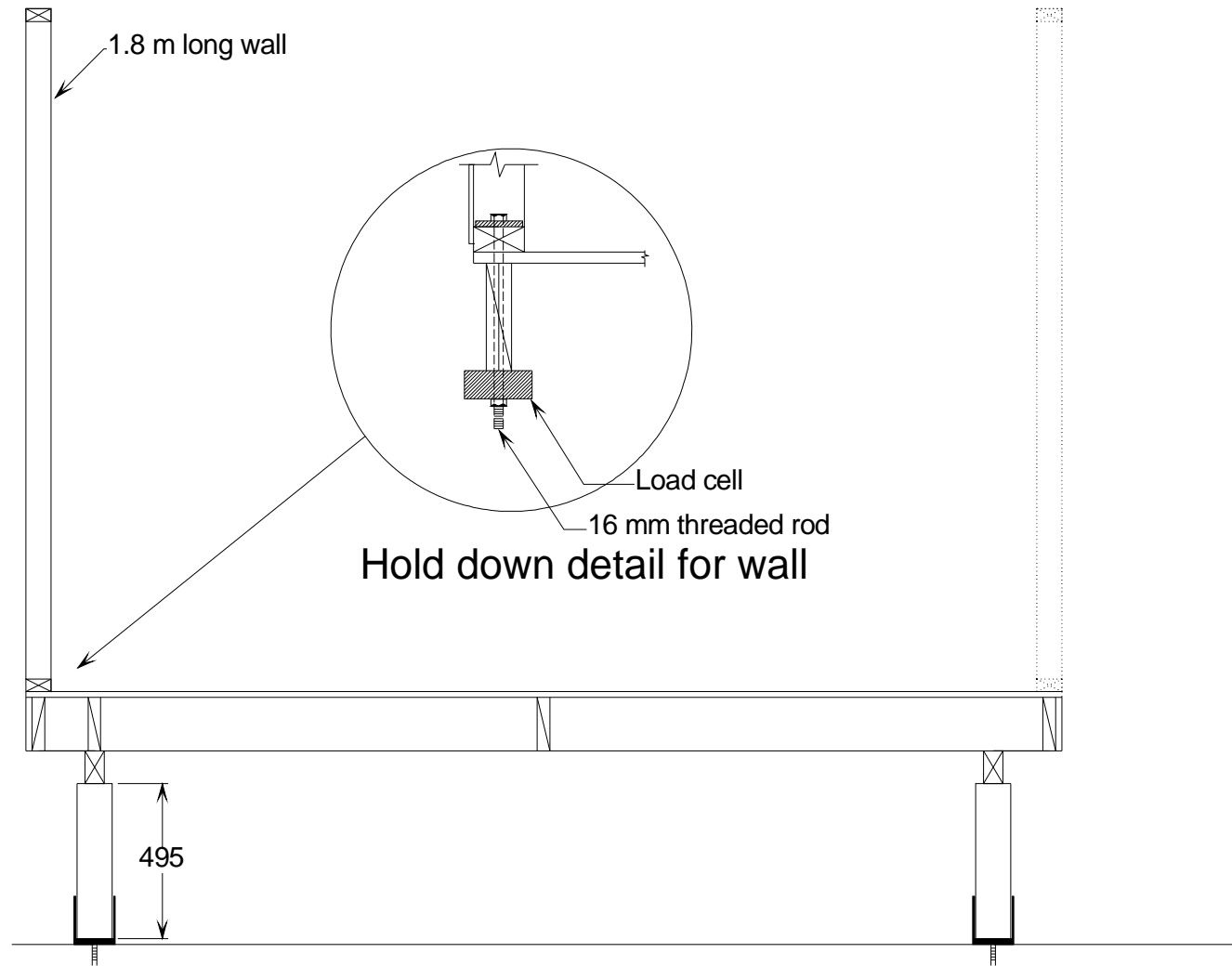
The blocking remained attached to the flooring and joists, but rotated between the joists, and this movement was expected to be causing the other major component of wall deflection.



**Figure 21. Plan of floor test specimen**



**Figure 22. Section A-A of floor test specimen**  
 (See Figure 21 for location of A-A)



**Figure 23. Section B-B of floor test specimen**  
 (See Figure 21 for location of B-B)

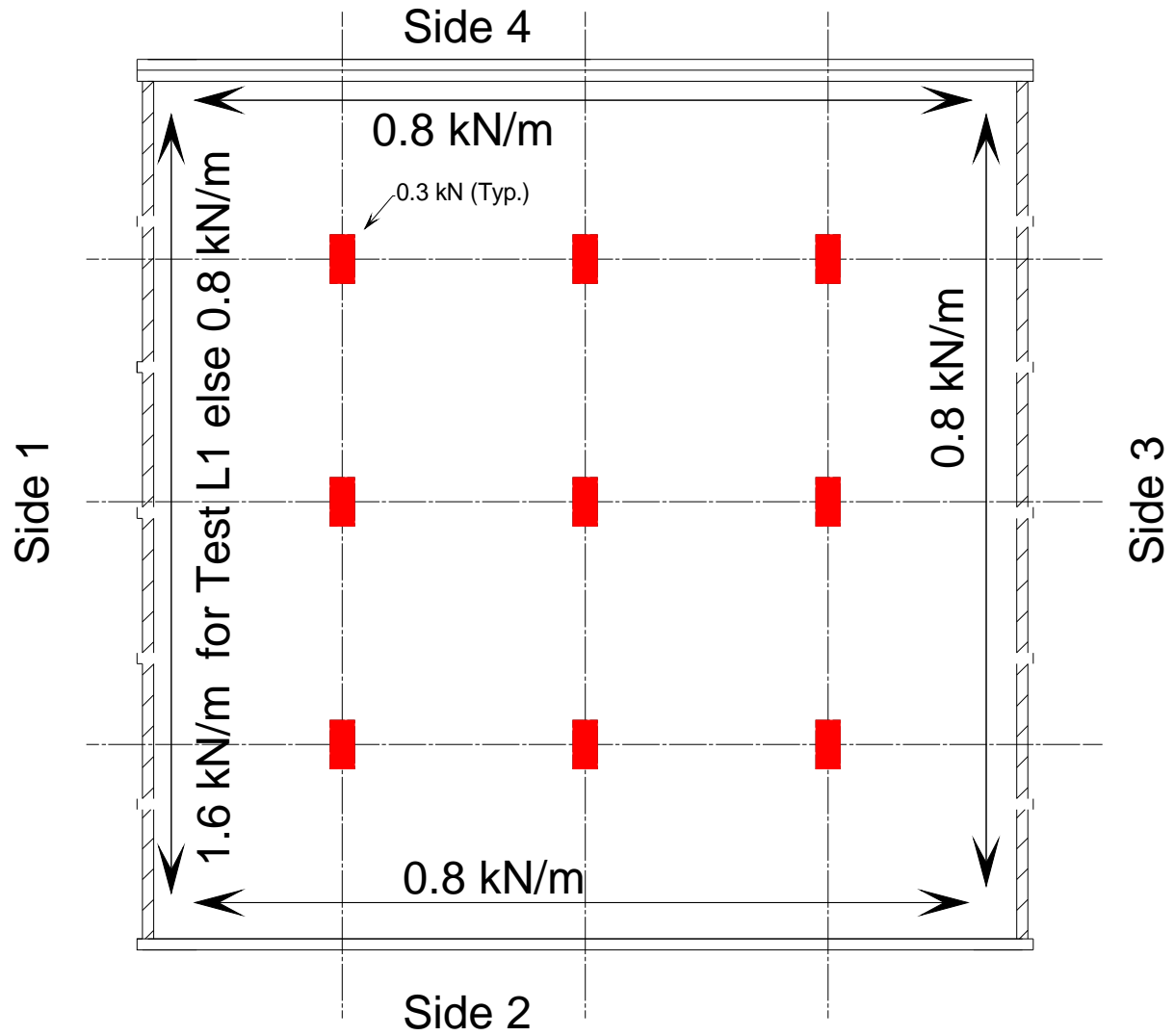
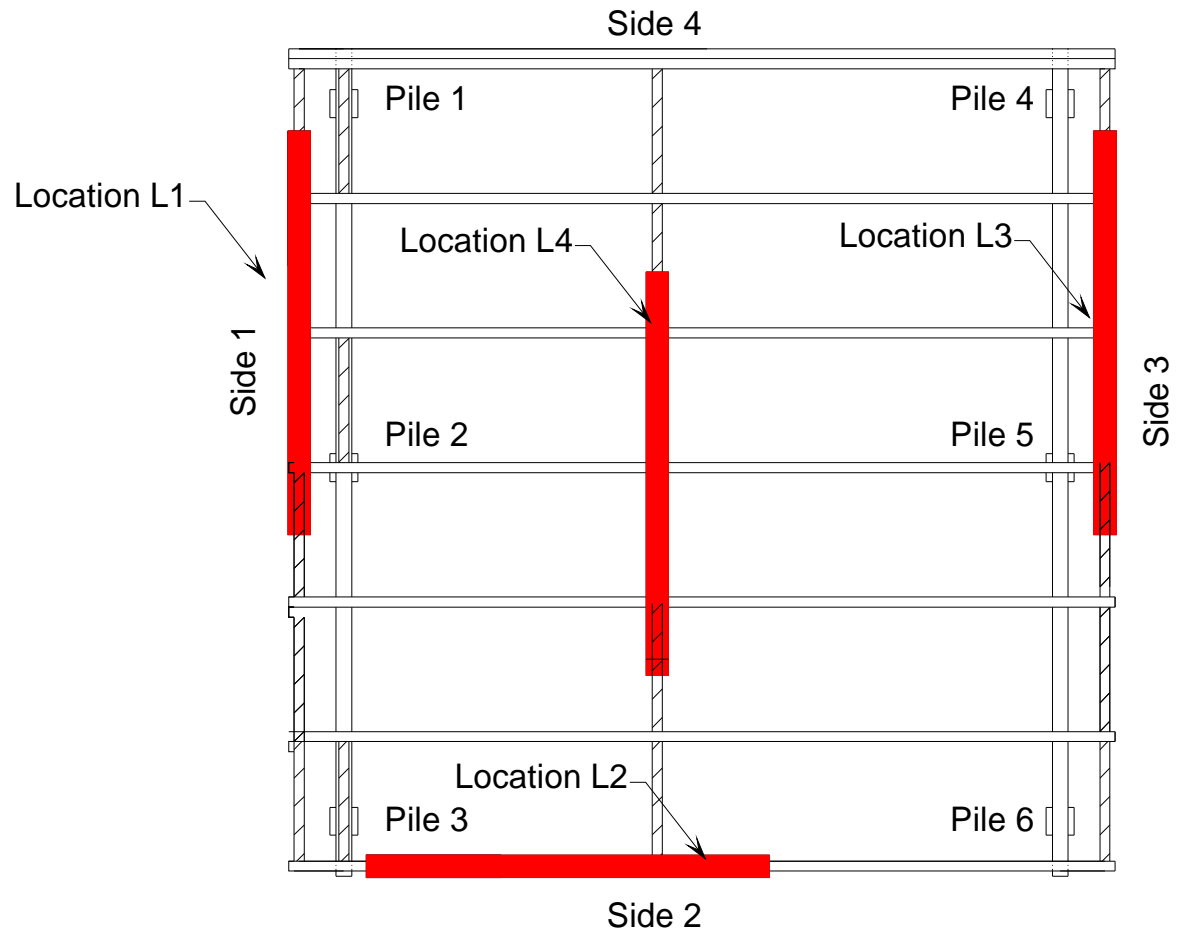


Figure 24. Added floor weights





A single test wall was used at each of the above locations

**Figure 25. Location of test wall**

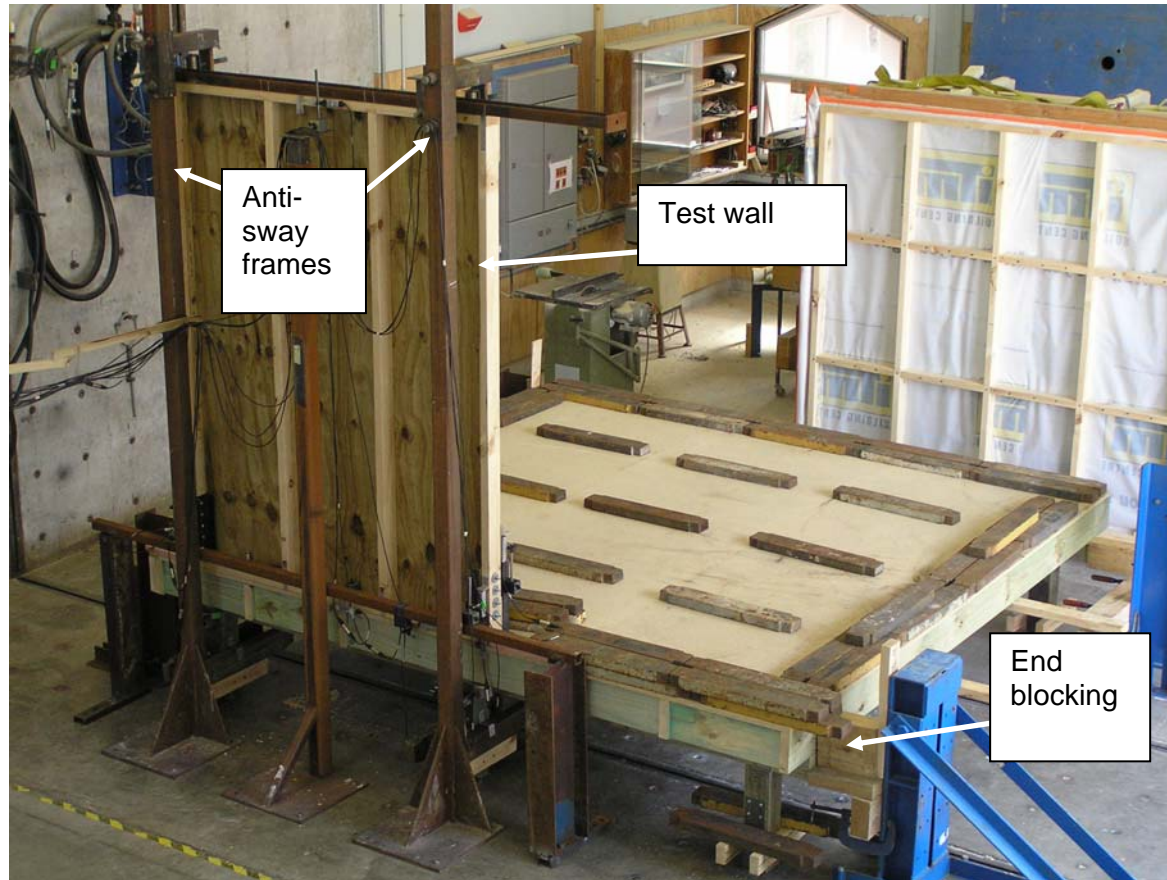
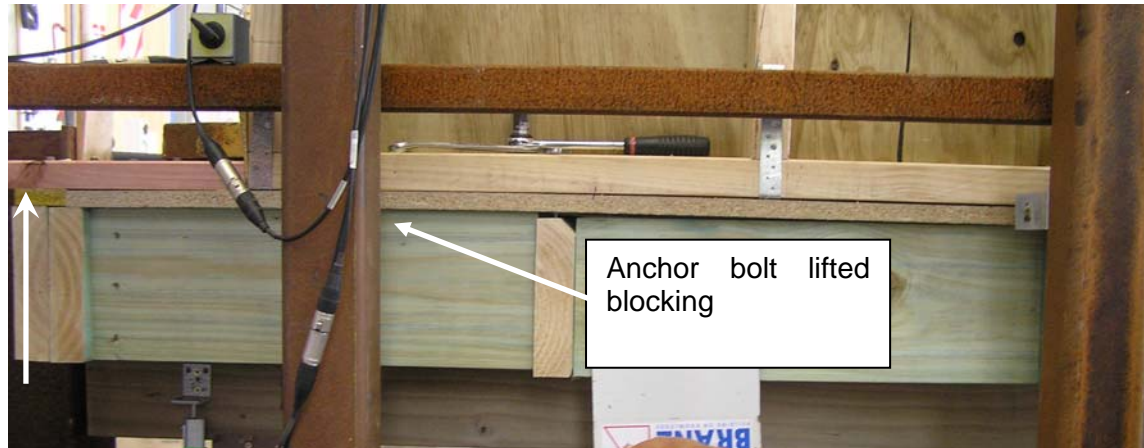


Figure 26. Test L1 – general view



**Figure 27. Test L1 – uplift at racking force = 7.42 kN push at tension end of wall**



**Figure 28. Test L1 – uplift at racking force = 8.42 kN pull at tension end of wall**



Figure 29. Test L1 – close-up of Figure 28



Figure 30. Test L1 – uplift at racking force of 8.42 kN pull at compression end of wall



Figure 31. Test L1 – curvature of Side 1 from uplift of joists from bearer

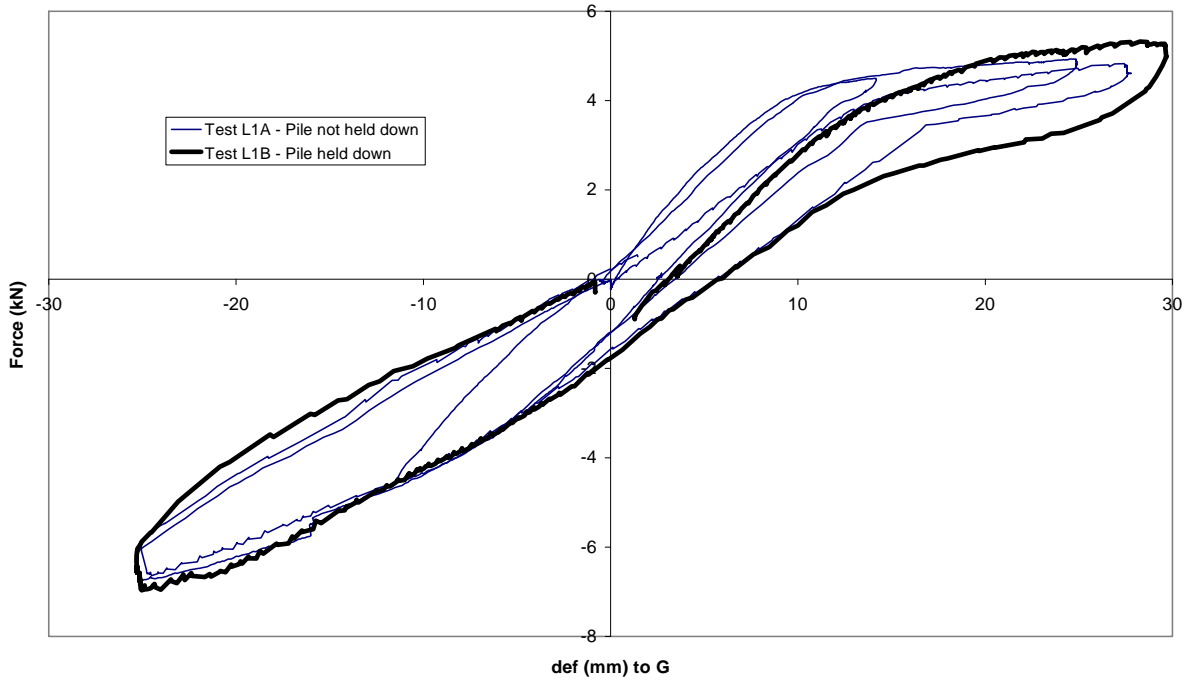


Figure 32. Hysteresis loops – Test L1A and L1B

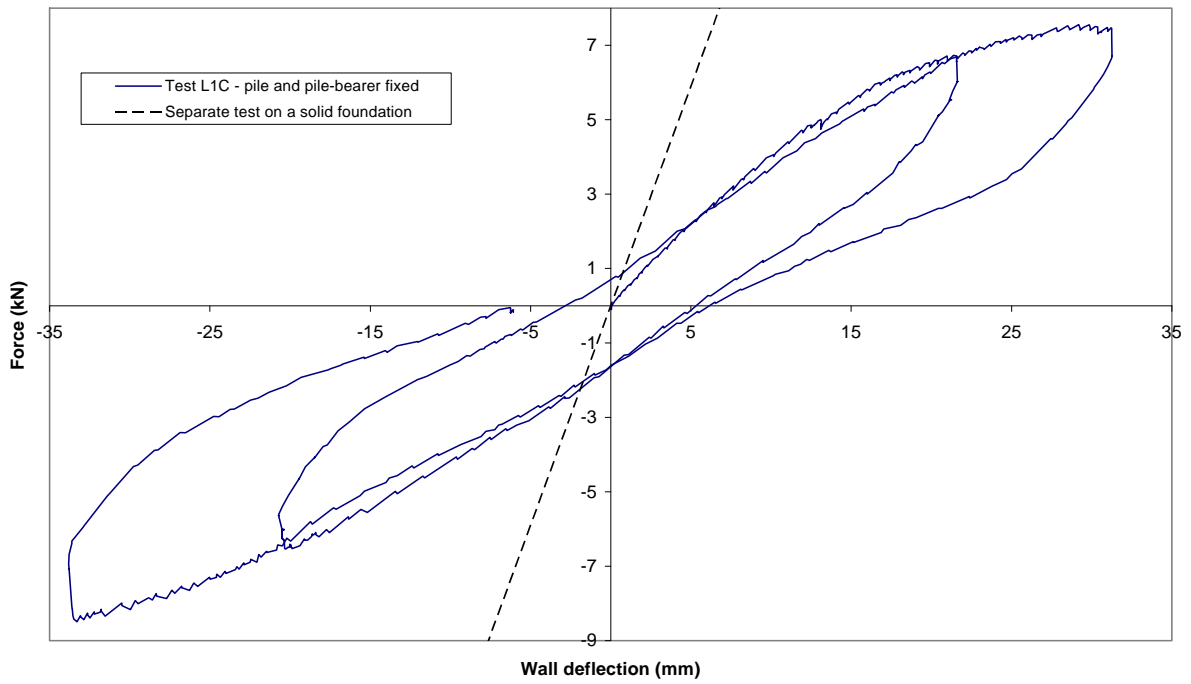
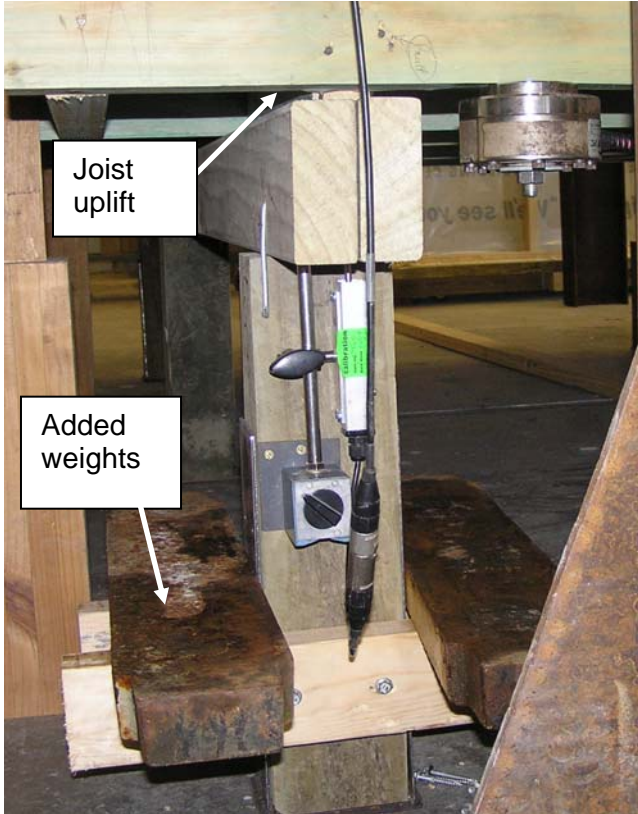


Figure 33. Hysteresis loops – Test L1C

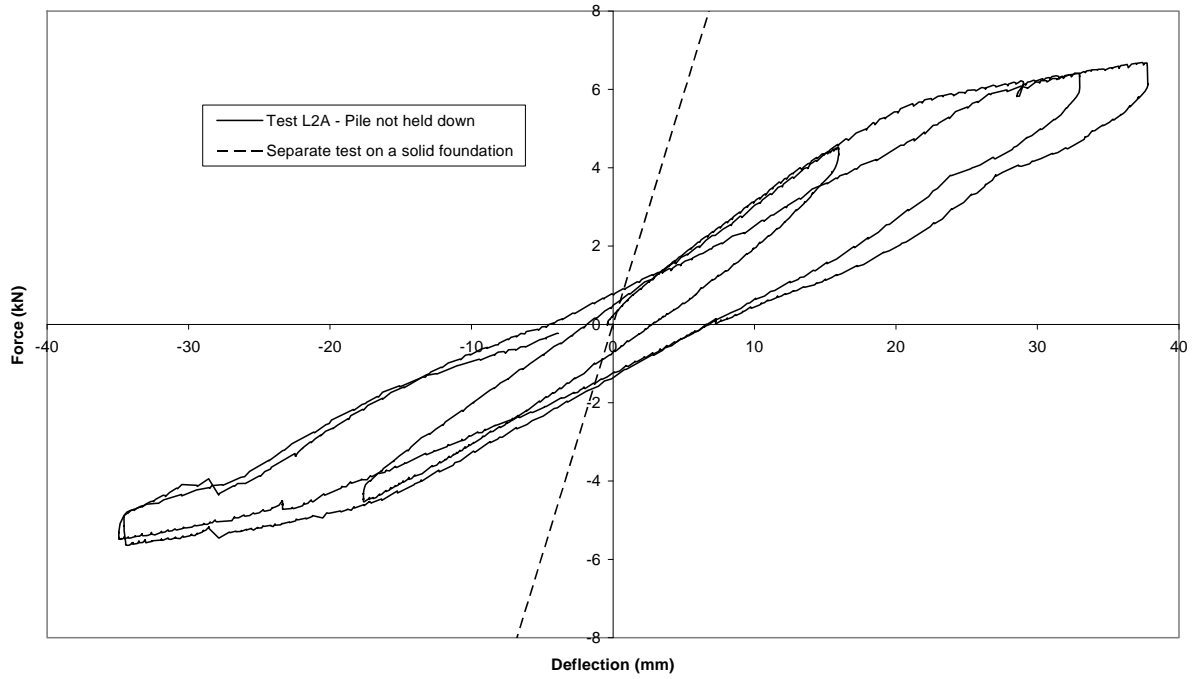




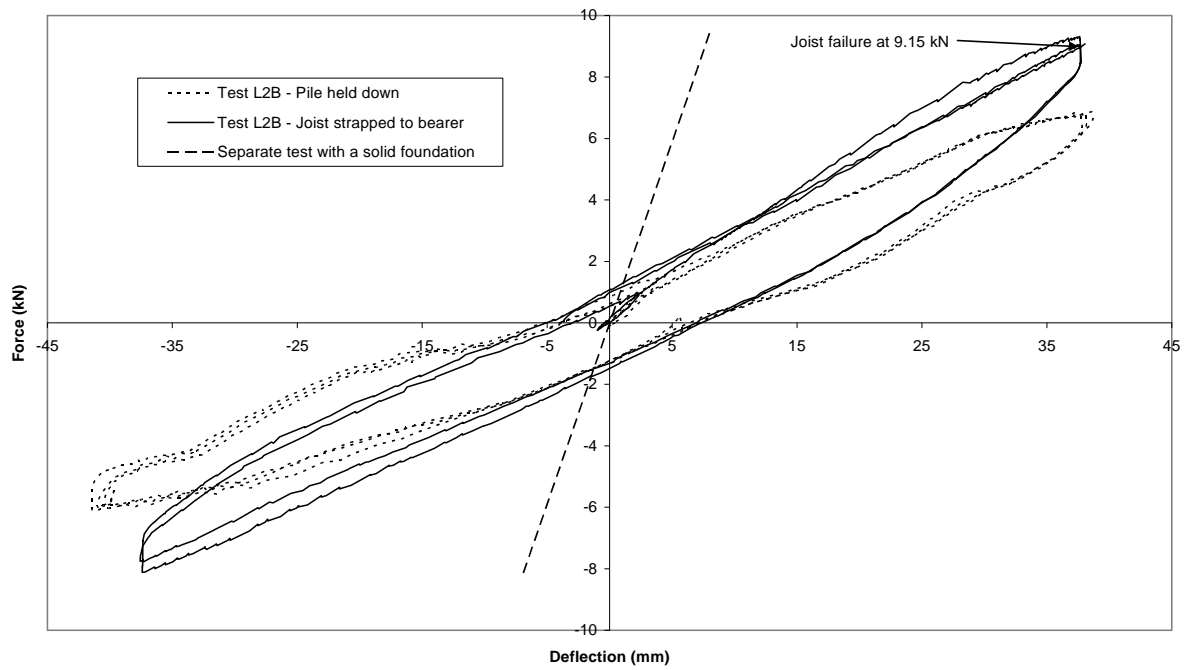
**Figure 34. Test L2 – uplift of joist from bearer**



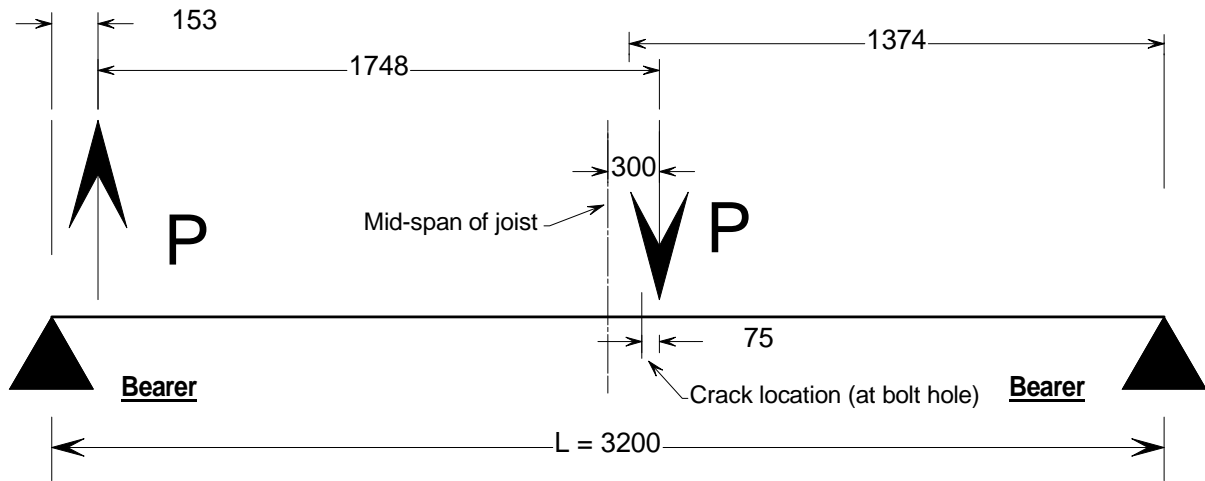
**Figure 35. Test L2 – crack in joist**



**Figure 36. Hysteresis loops – Test L2A**

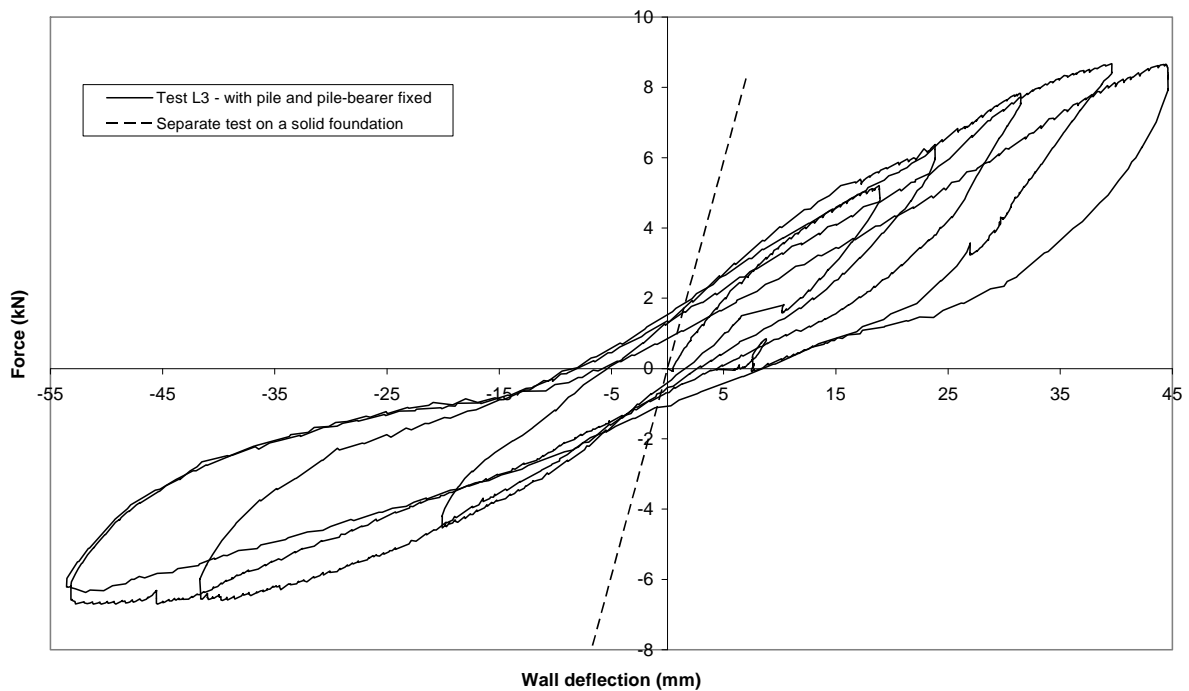


**Figure 37. Hysteresis loops – Test L2B**



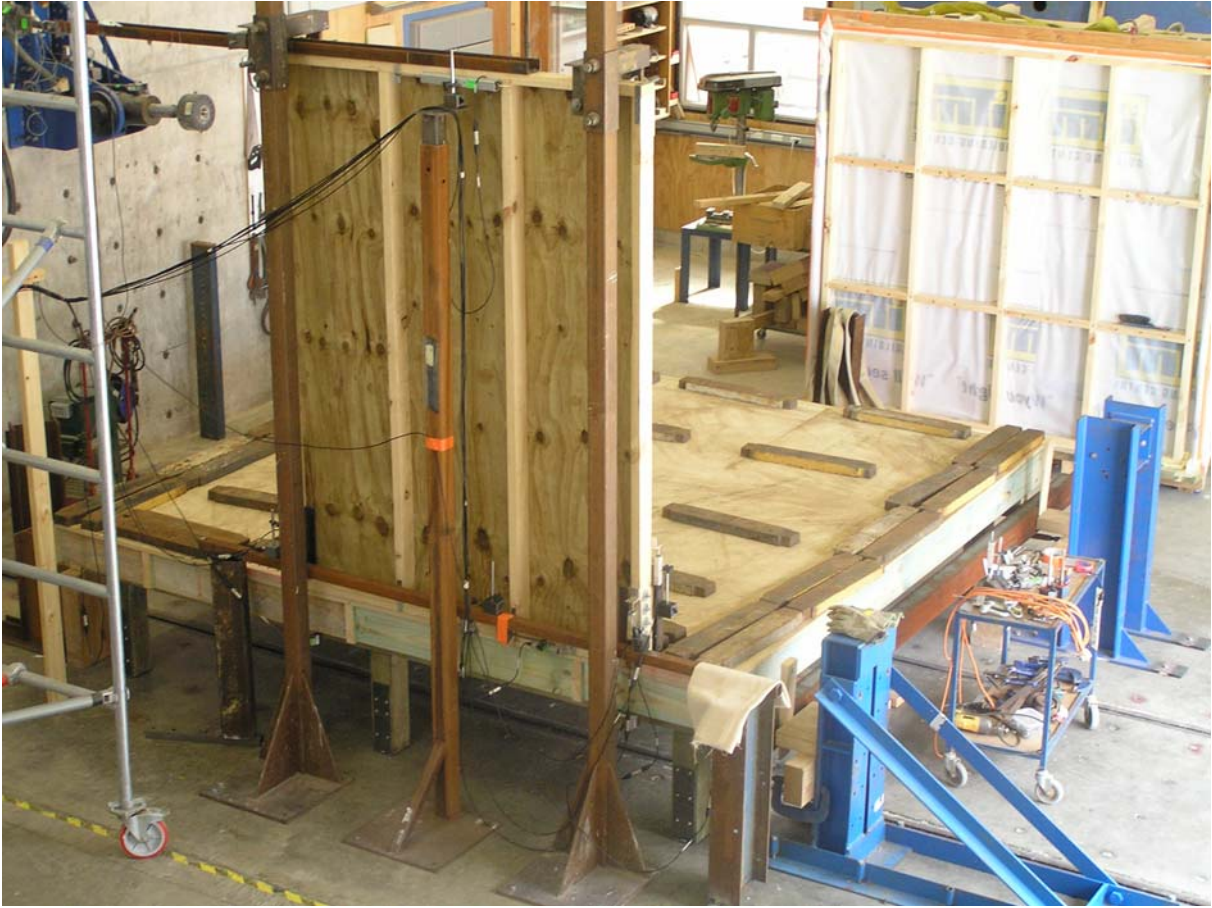
For a bracing wall of height 2.4 m and lever arm 1748 mm, with bracing force 9.15 kN:  
 End downwards reaction =  $P = 9.15 \times 2.4 / 1.748 = 12.56$  kN  
 RHS end reaction =  $1748/3200P = 0.546P$ .  
 Moment at crack location =  $1.374 \times 0.546 - 0.075P = 0.675P = 8.48$  kNm

**Figure 38. Calculation of bending moment at joist flexural failure location**



**Figure 39. Hysteresis loops – Test L3**





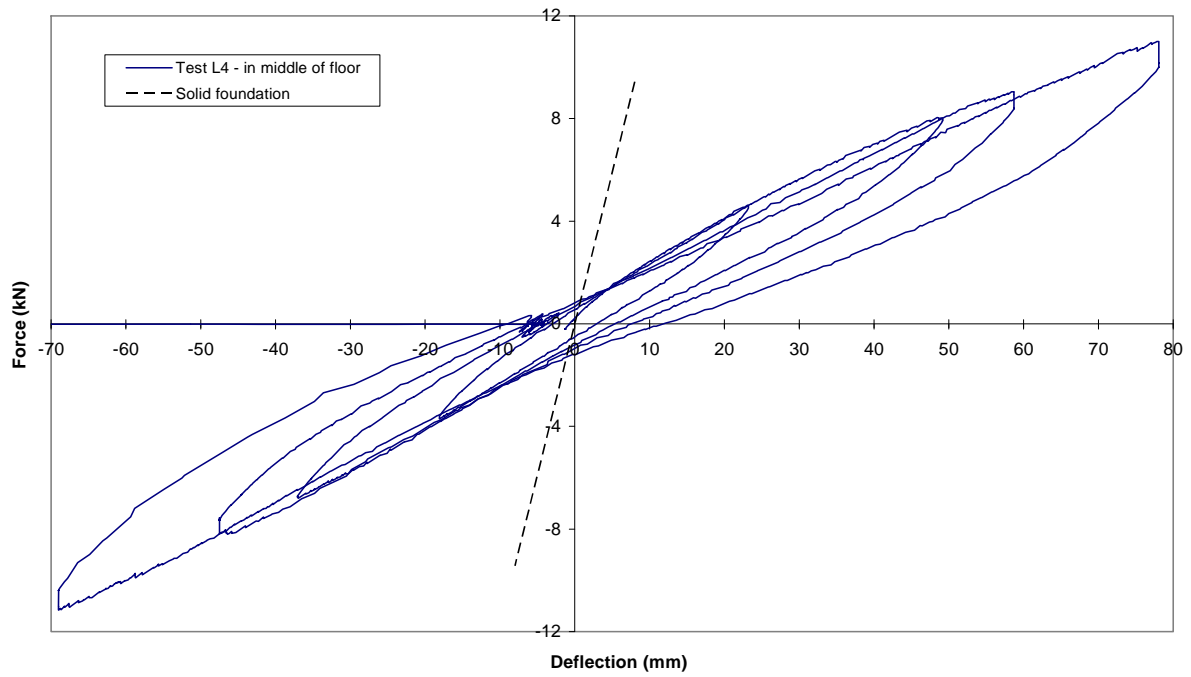
**Figure 40. Test arrangement – Test L3**



**Figure 41. Nail pull-out from joist –Test L3**



**Figure 42. Deflections along the loaded side of Test L3**



**Figure 43. Hysteresis loops – Test L4**



**Figure 44. Test L4 – specimen at peak push load**

## APPENDIX B. PLASTERBOARD JOINT TESTS

Three specimens were constructed to measure the shear strength of a plastered paper-tape joint. These are illustrated in Figure 45 and Figure 46. One coat of stopping plaster was placed over the joint and a paper tape laid into this plaster. After 24 hours a second coat of stopping plaster was applied. Testing commenced one week later. The loading rate was at 0.2 kN/second.

The three failure loads were 4.47 kN, 4.67 and 3.51 kN. The last result was rejected as the failure was peeling back of the paper tape from the plasterboard rather than rupture of the paper tape. The average strength from the first two tests was:

$(4.47+4.67)/2/0.8 \text{ m} = 5.7 \text{ kN/m}$  (this is taken as the average strength of these joints),

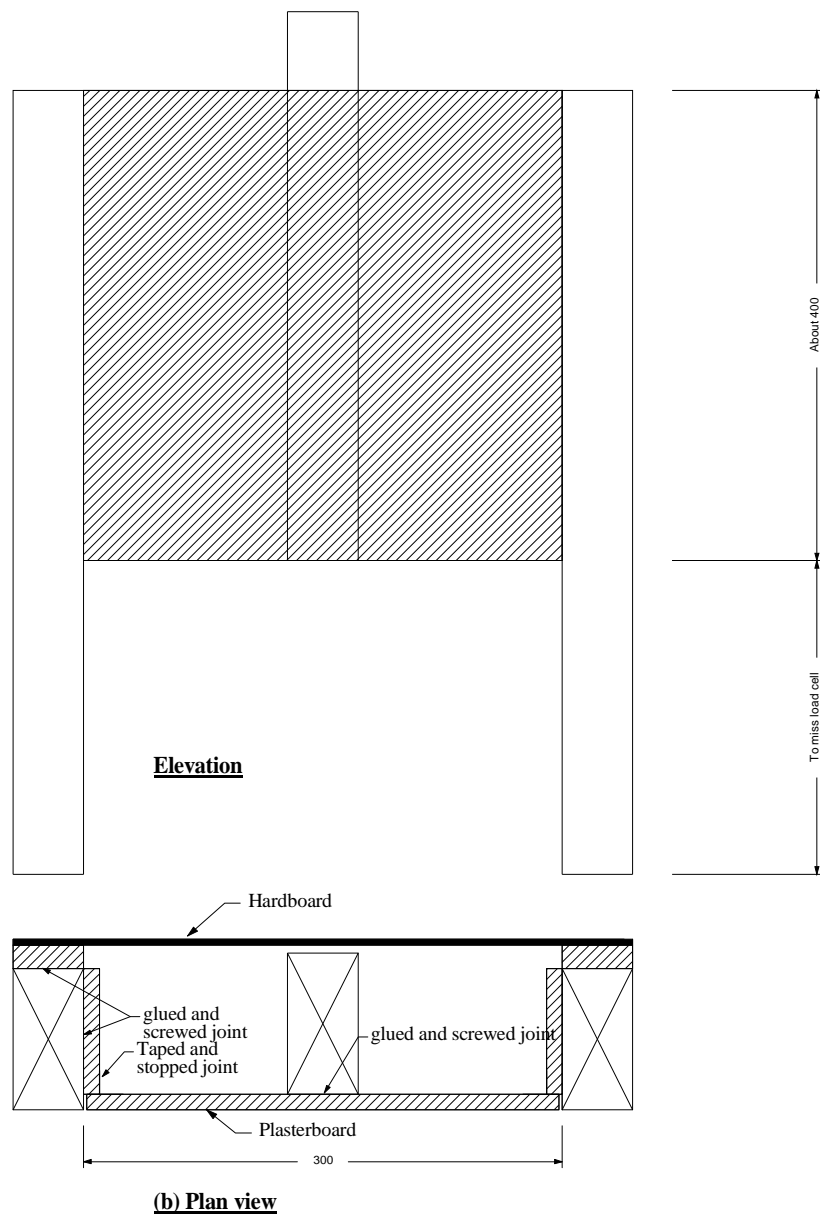
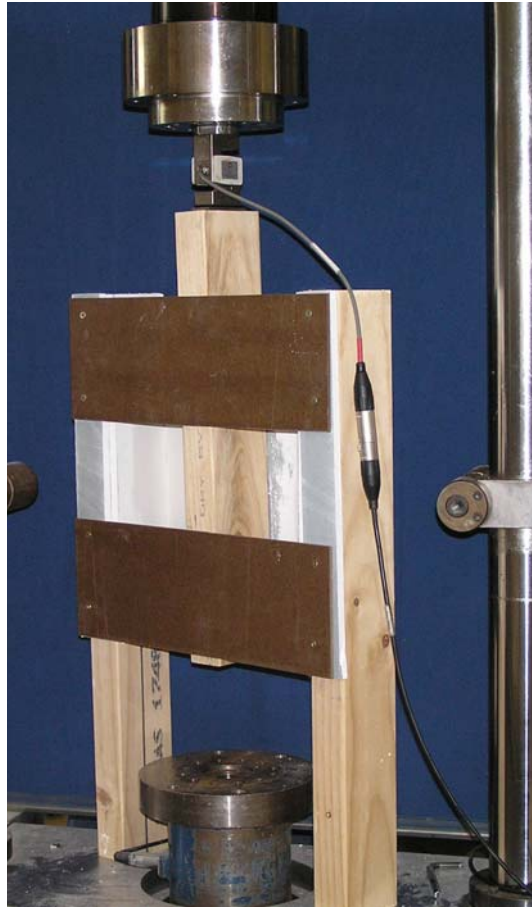


Figure 45. Details of plaster joint test specimen



**Figure 46. Photograph of plaster joint test specimen in Dartec test machine**

# APPENDIX C. TENSION STRENGTH OF STUD TO BOTTOM PLATE NAILED JOINT

## C.1 Tensile strength of nailed bottom plate-to-stud joint

Rocking action of timber framed walls is usually associated with either lifting of the stud from the bottom plate or lifting of the bottom plate from the foundation beam as shown in Figure 2, Figure 47 and Figure 48. Tests measuring the strength of the stud/bottom plate joint are discussed in this Appendix and the results are compared with measurements reported elsewhere.

The monotonic tests were performed in the BRANZ Structures Laboratory Dartec test machine. The set-up is shown in Figure 49. The timber was short lengths of kiln-dried grade MSG8 radiata pine with the bottom plate being 90 x 45 mm and the stud being 90 x 35 mm. The stud was held in the hydraulic grips in the machine top jaws and the bottom plate bolted to the machine bottom platen. The load rate was based on the P21 test method, assuming that the bracing test results are performed at a deflection rate of 4 mm/second. It was further assumed that 50% of the wall movement was due to wall 'rocking' by lifting of the stud and that the test wall had an aspect ratio of 2.0. This resulted in a plate-to-stud separation rate of  $50\% \times 4/2 = 1$  mm/second which was used in tests described below.

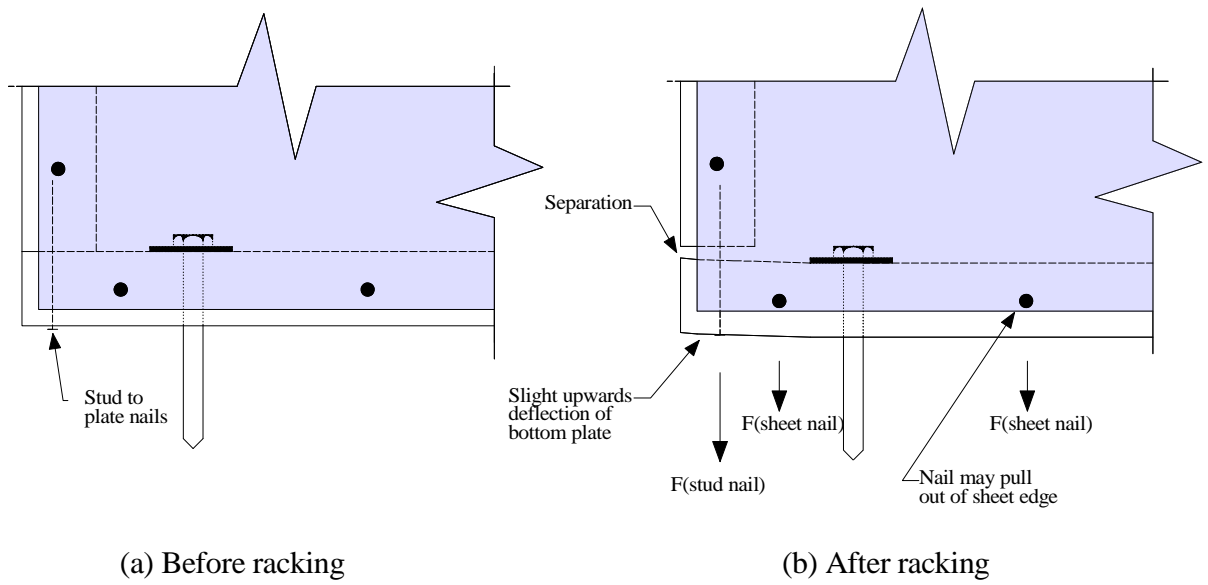
Ignoring the skewed nail options, Table 8.19 of NZS 3604 specifies two methods for connecting wall studs to plates; namely two 100 x 3.75 mm long flat-head nails or three 90 x 3.15 mm power-driven nails. The NZS 3604 Standards Committee designed the joint to meet the shear demand of this joint under face loading. Based on tests (Shelton 2004(b)), BRANZ has issued opinions<sup>i</sup> for some nail manufacturers that only two of their power-driven nails may be used at these joints in NZS 3604 buildings, provided the wall height does not exceed 2.7 m. Thus, the bracing wall testing described in this report used two such nails to connect the studs to the frames. The testing described in this Appendix measured the tensile strength of the following stud-to-plate connections:

- (1) two bright 100 x 4 mm long flat-head nails
- (2) two 90 x 3.15 mm coated and galvanised power-driven nails
- (3) two 90 x 3.15 mm coated but not galvanised power-driven nails.

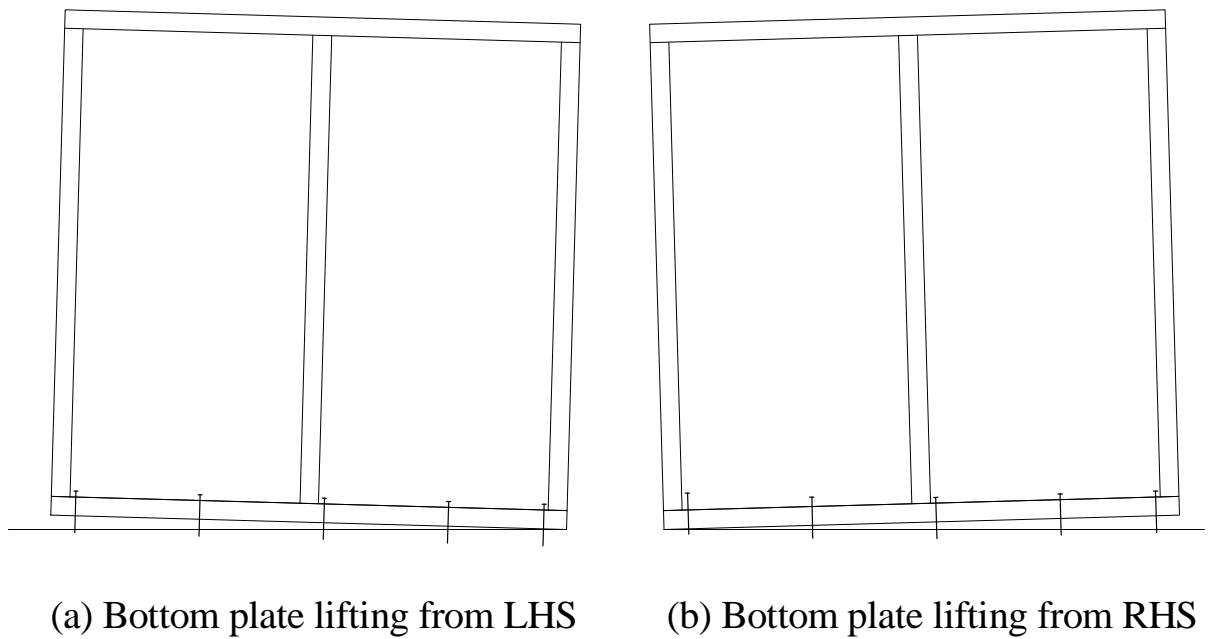
---

<sup>i</sup> This information is quoted with the consent of clients, Paslode New Zealand (formerly ITW Construction Products).





**Figure 47. Lifting of stud from bottom plate**



**Figure 48. Lifting of bottom plate from timber floor**



Figure 49. Test set-up used to measure stud/plate tension strength

Sample plots for load versus pull-out deflection of the galvanised power-driven nails are shown in Figure 50. Note that after the peak load has been reached the load resisted by power-driven nails drops rapidly until reaching a slightly sloping plateau. The drop is attributed to the failure of the nail/timber glue bond. The 'residual load' is expected to be due to the nail/timber friction.

Table 13 lists statistical data on the peak load, the resisted load at 4 mm deflection and, for the power-driven nail tests only, the 'residual load'. It can be seen that the power-driven nails had significantly stronger pull-out strength. A large variability can be expected due to variation of end grain conditions.

Using a load rate of 2 kN/minute, Herbert and King (1998) gave peak pull-out strength of two 90 x 3.15 mm gun nails driven through a 45 mm thick bottom plate into the end grain of a 90 x 35 mm timber stud as 4.1 kN. This is similar to the value in Table 13 (4.26 kN), but as noted in the paragraph above it is the strength at significant joint movement, say 4 mm, which is of most significance.

Table 13. Withdrawal strength (kN) of two-nail plate-to-stud connection

	Nail type		
	Power	Power	Hand
Galvanised?	Yes	No	No
Number of samples	6	8	7
<b>First peak strength (kN)</b>			
Mean strength/joint	4.26	3.05	1.61
Std/Dev joint strength	0.56	0.63	0.34
<b>Post Peak (kN)</b>			
Mean strength/joint	2.98	1.81	
Std/Dev joint strength	0.64	0.62	
<b>4 mm deflection strength (kN)</b>			
Mean strength/joint	2.61	1.53	1.16
Std/Dev joint strength	0.29	0.71	0.20

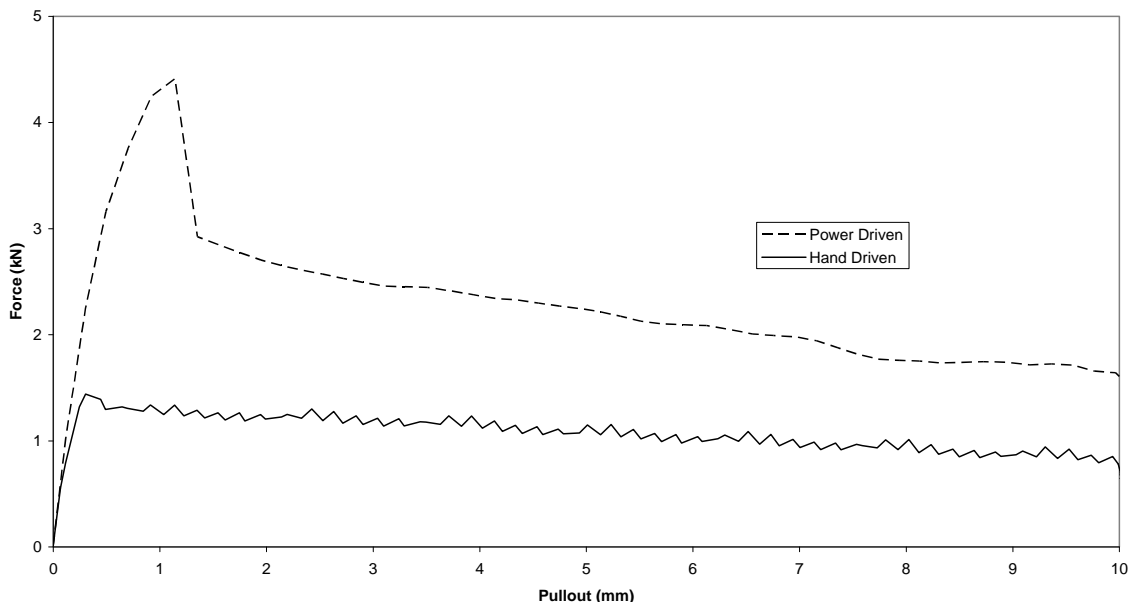


Figure 50. Typical relationship between tension load and two-nail stud/plate joint deflection

## C.2 Tensile strength of bottom plate to timber foundation beam nailed connection

'Rocking' action of timber framed walls is usually associated with either lifting of the stud from the bottom plate or lifting of the bottom plate from the foundation beam. This section presents tests measuring the latter strength.

The monotonic tests were performed in the BRANZ Structures Laboratory Dartec test machine using a load rate of 1 mm/second for the reasons discussed in Section A.1. The set-up is shown in Figure 51. A strip of particleboard was nailed to a length of 90 x 45 mm kiln-dried radiata pine to form a simulated joist. A length of 90 x 45 mm kiln-dried radiata pine bottom plate was nailed to the joist using either a bright 100 x 4 mm flat-head nail or a 90 x 3.15 mm power-driven coated nail (non-galvanised).

Table 8.19 of NZS 3604 specifies two options for connecting external wall bottom plates and internal bracing walls to floor framing, namely two 100 x 3.75 mm long flat-head bright nails or three 90 x 3.15 mm power-driven nails at 600 mm centres. For



internal walls, the options are one 100 x 3.75 mm long flat-head nail or one 90 x 3.15 mm power-driven nail at 600 mm centres. In the bracing tests of this Study Report, the fixing used was two 100 x 4 mm long flat-head nails at 600 mm centres.



Figure 51. Test set-up used to measure bottom plate to timber joist tension strength

Sample plots are shown in Figure 52. Note that with power-driven nails after peak load has been reached, the load drops rapidly until reaching a sloping plateau. The sudden drop is attributed to the failure of the nail/timber glue bond. The residual load is expected to be due to the nail/timber friction.

Table 14 lists statistical data on the peak load, the resisted load at 4 mm deflection and, for the power-driven nail tests only, the 'residual load'. It can be seen that the power-driven nails had significantly stronger pull-out strength, but only slightly greater strength at 4 mm pull-out deflection.

It is of interest to compare the results of Table 13 (for end grain nailing) and Table 14 (for side grain nailing). The 4 mm slip strength of power-driven nails was greater than hand-driven nails for fixing into end grain. However, the two were almost equal for fixing into side grain. The side grain hand-driven nails had almost twice the pull-out strength as for end grain.

From Table 14, an average bottom plate/foundation connection strength for a pair of hand-driven 100 x 4 bright flat-head nails is  $2 \times 1.54 = 3.08$  kN. Despite being tested at a slower rate of 2 kN/minute, Herbert and King (1998) measured a larger average first peak pull-out strength (3.8 kN) of two 100 x 4 mm hand-driven bright nails. On the other hand, Thurston (1993) measured the average strength as  $2 \times 1.32 = 2.64$  kN using an even slower load rate of 1 kN/minute, which appears to be compatible with the values measured in this test series (note that greater load rates generally result in greater strengths).

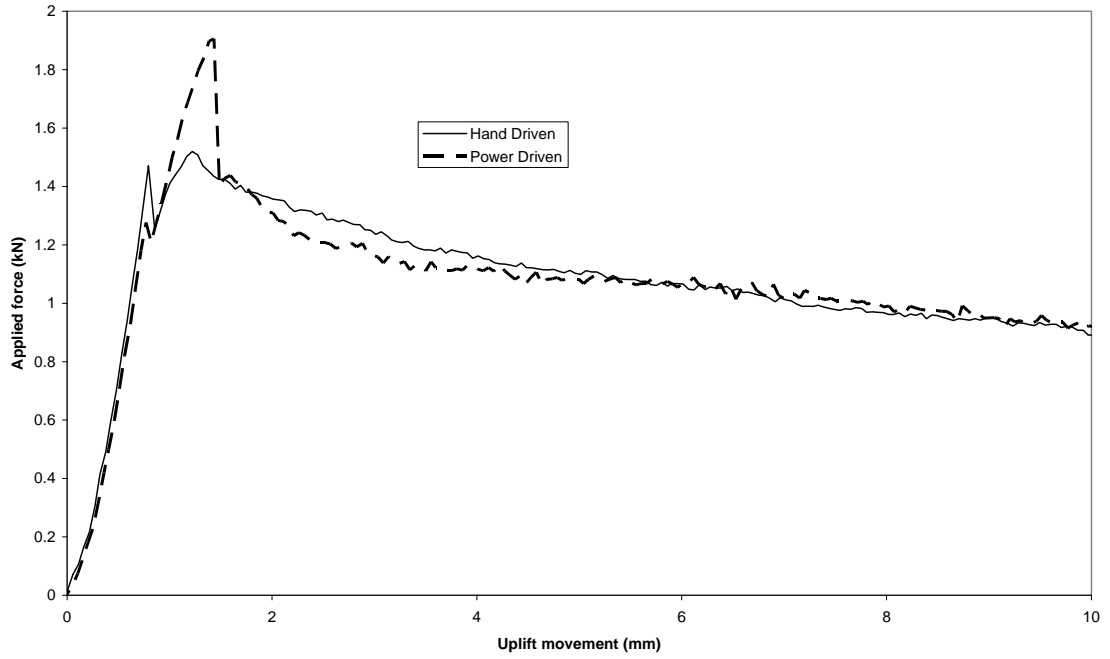


Figure 52. Typical relationship between tension load and single nail plate to foundation beam joint deflection

Table 14. Withdrawal strength of single nail on plate-to-stud connection

	<b>Power</b>	<b>Hand</b>
Number of samples	6	8
<b>First peak strength (kN)</b>		
Mean strength/joint	2.06	1.54
SD joint strength	0.19	0.23
<b>Post peak strength</b>		
Mean strength/joint	1.57	
SD joint strength	0.22	
<b>4 mm deflection strength (kN)</b>		
Mean strength/joint	1.47	1.25
Std/Dev joint strength	0.21	0.19

# APPENDIX D. STRENGTH OF P21 END RESTRAINT

## D.1 Magnitude of 'supplementary' uplift restraint

In Appendix B.2 of Thurston (2003), he measured the strength of the 'P21 end restraint' through 35 mm and 45 mm thick timber studs (kiln-dried machine stress graded F5 radiata pine) using an average from six replicas. The joints were cyclically tested at 0.2 mm/second. The averaged backbone curves to the hysteresis loops are given in Figure 53 for a 'four-nail' joint and indicate similar strengths for both power-driven nails and hand-driven nails with little variation due to thickness of stud. The value used for simulation of 'three-nail' P21 restraint (4.85 kN) is taken from Figure 53 at a 'fastener slip' of 6 mm, and is proportioned for three hand-driven nails using the mean test results for 35 and 45 mm studs. At 4 mm slip the value is 4.5 kN.

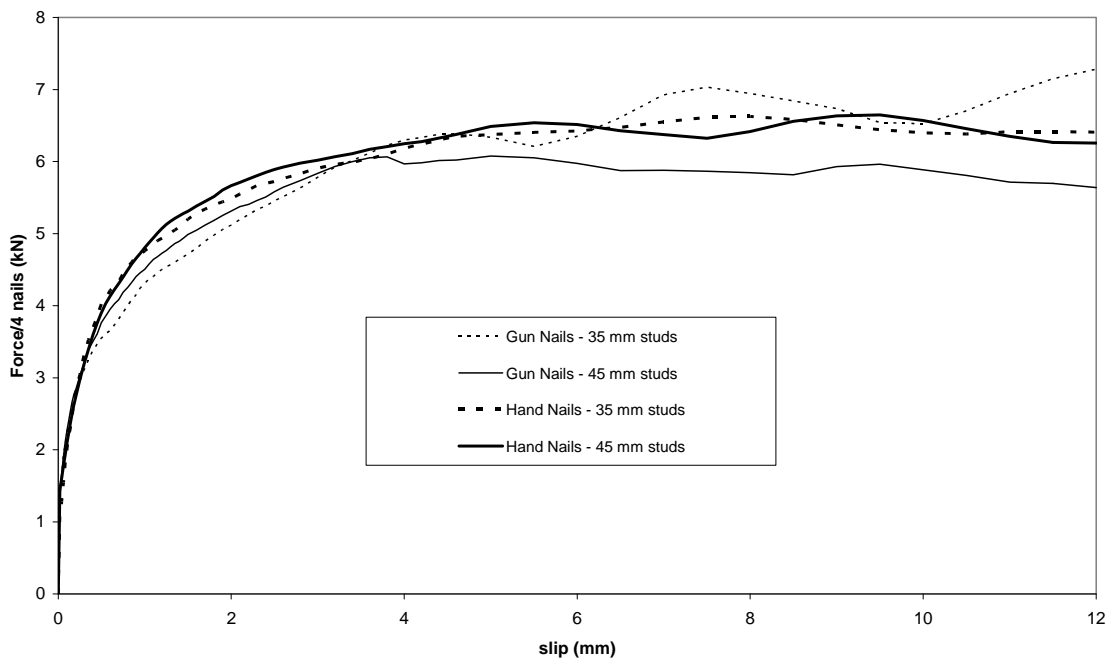


Figure 53. Backbone curves to hysteresis loops for a four-nail end restraint joint