



YOUR WALLS
OUR PRIDE



Unitex Base Board[®] Cavity System Technical Manual



Unitex Base Board[®] Cavity System Technical Manual

This Technical Manual describes installing Unitex Base Board[®] Cavity System onto a breathable Building Paper covered frame.

Contents	Page
1. Introduction	3
2. Design Criteria	5
3. Materials used in the Unitex Base Board® system	10
4. Installation Guidelines	19
5. Installation and Fixing Details	51
6. Technical Appraisal	66
7. Safety and Handling	67
8. Warranty	69

1. Introduction

Unitex® is an Australian owned and operated manufacturer and distributor of a wide range of facade wall enhancing building products suitable for both residential and commercial architectural projects. The range includes:

- Lightweight Wall Cladding Systems (Uni-EIFS®)
- Specialty Renders (Uni Dry Cote®, Unitex® Polymer Render, etc.)
- Applied Texture Finishes (Uni Trowel Décor®, Uni Dry Cote®, etc.)
- Masonry paints (Uni-PTC®, etc.)
- Cement based architectural mouldings and NLB columns (Uni-Shape®)
- PUR coated profiles (Tex Moulds)
- Accessory product range

Unitex® offers two CodeMark compliant EIFS product systems to the building industry:

- Unitex Base Board System® for Cavity construction
- Unitex Base Board System® that is directly fixed (with non-cavity) to the building frame.

The performance requirements for a cavity wall are different to the requirements for direct fix (or non-cavity) cladded walls. This is due to the purpose and nature of a cavity wall. Any water that passes through the primary weather defence of the outer wall will gradually be removed from the cavity either through weep holes or evaporation. A cavity system allows water to enter the cavity as long as drainage solutions are present whereas a non-cavity direct fix system must prevent all water penetrations by the primary weather defence of the exterior wall.

1.1 Cavity System Outcomes

Water penetration through the external building envelope has proven to be a major problem for countries such as New Zealand and Canada. Whilst relatively few known cases of so-called “leaky buildings” have occurred in Australia, any underlying problems may take many years to become observable.

The Unitex Base Board® Cavity System is designed to remove moisture that has penetrated through or around the primary weather defence of the finished exterior wall. By doing this, the building’s structural integrity i.e. the framework, will not be compromised. Simply put, by design, water won’t be allowed to pool on wooden surfaces and slowly rot the frame.

1.2 Basic Description

Unitex® introduced External Insulation Finishing Systems (EIFS) to the Australian building products market over 25 years ago and has patented, developed and refined the accompanying product systems since 1982. This Manual describes the **Unitex Base Board® Cavity System**, how it is installed as the **exterior cladding for walls with a cavity**, and what may be expected from it as a building product system for exterior walls of Class 1a Residential as defined in the Building Code of Australia (BCA).

1.3 The Unitex Base Board® Cavity System is a fully specified system and consists of:

1. Uni Base Board®
2. Unitex® Cavity Closer
3. Unitex® Levelling Base Block (starter channel)
4. Unitex® Cavity Battens
5. Uni-Screw®/Washer Fixers (Mushrooms)
6. Unitex® Adhesive Foam
7. Unitex® Polymer Render
8. Uni-Mesh® IM 250
9. Uni-304® Angle
10. Uni Dry Cote® BBR (Base Board Render)
11. Uni-Shape® Sealant
12. Unitex® Applied Texture Finish such as Uni-Trowel Décor®
13. Uni-PTC® exterior surface coating
14. Unitex® Wedge Head Protector

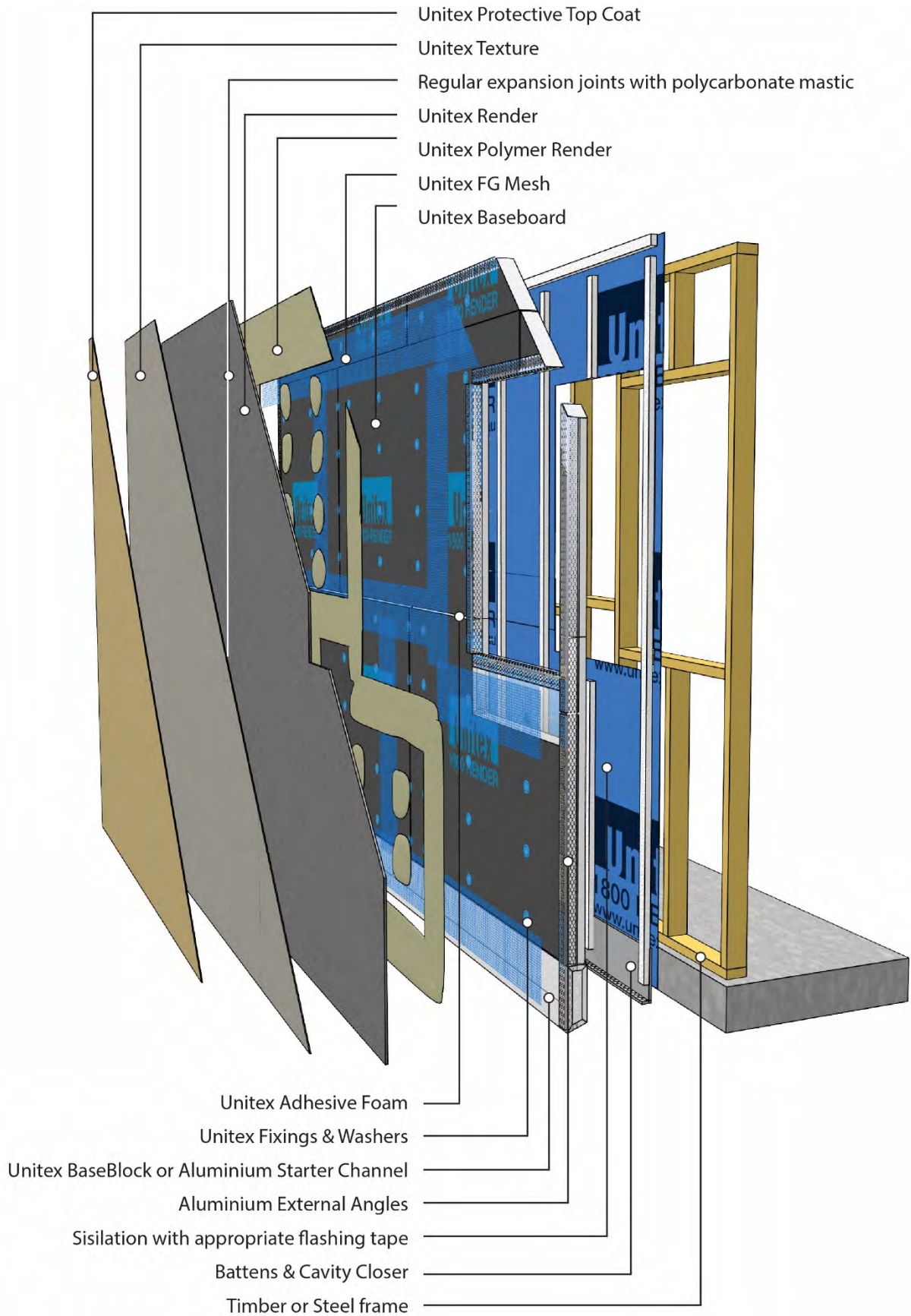

N.B. The use of any generic products instead of the dedicated and listed components will render the installation non-conforming to the CodeMark Compliance program.

Unitex[®] offers extra products such as **Unitex[®]-Cembond** primer and adhesion promoter and **Uni-Shape[®] Sill Blocks** that can be installed under windows. The use of these **optional**, additional products will enhance the finished wall.

Accessories used with the System which are **supplied by the building contractor** are:

1. Sarking
2. Sarking support
3. Flexible sill and jamb flashing tapes
4. Flashings
5. Cavity batten fixings
6. Waterproof membrane tapes
7. Window and door trim cavity air seal

More detailed information on these components is found in Section 3 of this Technical Manual.

2. Design Criteria

2.1 Installation Design

The only approved method of installing **Uni-Base Board®** on-site and building up the **Unitex Base Board® system** is by using and applying Unitex®-supplied components as detailed in Section 3 of this Manual. Compliance with the requirements of your local Building Authority/Building Surveyors is essential.

2.2 Concrete slab design

Concrete slabs should be finished with a straight and smooth edge where the sheets are expected to overlap. A rebated slab edge as is normally used for brickwork is well suited for Uni-Base Board® sheets to be used. The builder will need to provide a smooth and squared rebate for sheet installation and also consider external doorways. The rebate ought to be waterproofed prior to cladding installation. As is usual, no rebate is required at doorways.

2.3 Frame Structure

The frame structure must be built in accordance with the Building Code of Australia (BCA) and with the relevant Australian Standards such as AS 1684-2010 “Timber Frame” and AS/NZS 4600-2005 and the NASH Standard for “residential and low-rise steel framing (Part 1) 2005”.



2.4 Stud wall design

As Uni-Base Board® sheets are fastened through battens and building wrap (sarking) onto timber or metal studs, spacing of the wall studs needs to be considered in relation to expected wind loads. In normal situations, stud spacing is up to a maximum of 600 mm. In high wind areas this can be reduced to 450 mm and less. Builders should check with local building regulations to determine the appropriate Wind Classification and space the fixers appropriately using information from Table 1 (below). Fixing off-stud is allowed as specified later. In certain cases, extra noggins for back blocking may be required.

Make sure that there is adequate framing around windows and doors to perimeter fix the panels. An extra stud is usually required on internal and external corners so that both internal plaster-board sheets and external Uni-Base Board® sheets can be adequately fixed.

2.5 Wind Pressure Design

The Unitex Base Board® System with Cavity is suitable for use in non-cyclonic wind zones up to and including N3. Uni-Base Boards® must be fixed through the cavity battens and cavity spacers to the wall framing at the maximum centres specified in Table 1.

Table 1. Uni-Base Board® Fixing Centres for Edges and Intermediate Studs

BCA Wind Class	Maximum fixing centres (mm) with studs at maximum 600 mm centres	Maximum fixing centres (mm) with studs at maximum 400 mm centres
N1	300 ¹	300 ¹
N2	300 ¹	300 ¹
N3	200 ²	300 ¹

¹ One fixing is required into each noggin and top and bottom plates at mid-nog length.

² Fixings are also required into each noggin at 200 mm centres and top and bottom plates at mid-nog length.

The face load resistance of Unitex Base Board® Cavity System installations on buildings situated in BCA Wind Classes outside of non-cyclonic N3 is to be determined by specific engineering design. Please contact Unitex for additional information.

The Unitex® reinforced coating system is the same for all coating thicknesses and allows minimum deflection. Unitex® does not approve or support the use of EPS sheets below 50 mm thickness due to potential deflection in installation.

The information in Table 1 was determined by BRANZ as part of the weathertightness verification testing carried out on a test panel constructed with the Unitex Base Board® System with Cavity onto a wooden frame and included wall penetrations such as a window, a meter box and a balustrade.

2.6 Bushfire Attack Levels performance of Unitex Base Board® System

Bushfire resistance performance of the Unitex Base Board® System was tested in accordance with AS 1530.8.1-2007 by an accredited external testing authority.

The coating system applied to the EPS sheets is critical to the performance as the following table explains:

Table 2. Results of Bushfire Attack Level testing to AS 1530.8.1-2007 by Exova Warringtonfire

Substrate	Coating System	Result
75 and 100 mm Uni-Base Board®	8 mm Uni Dry Cote® BBR 1 mm Uni-Trowel Decor®	BAL-29 achieved in testing
75 and 100 mm Uni-Base Board®	16.5 mm Uni Dry Cote® BBR 1 mm Uni-Trowel Decor®	BAL-40 achieved in testing

Whilst the test was carried out on a test wall with direct fix (non-cavity) Unitex Base Board System® using 75 mm EPS, the accredited external testing authority has given Unitex® an opinion that both BAL-29 and BAL-40 would be achieved for both 75mm & 100mm EPS and using a Unitex Base Board® System with Cavity construct. The Test Reports are available from Unitex.

2.7 Heating Appliances, Fireplaces, Chimneys and Flues

The Unitex Base Board® Cavity System has not been assessed for construction associated with heating appliances and must not be used as such.

2.8 Fire

The Unitex Base Board® Cavity System is suitable for use on exterior walls when positioned a minimum of 900 mm from an allotment boundary (other than the boundary adjoining a road alignment or other public space), and on walls positioned a minimum of 1.8 m from another building on the same allotment.

The fire hazard indices of the Unitex Base Board® Cavity System have been assessed in accordance with AS 1530.3-1999 and are:

Table 3. Results of Testing to AS/NZS 1530.3:1999 “Simultaneous Determination of Ignitability, Flame Propagation, Heat Release and Smoke Release” on Unitex Base Board® System by CSIRO Materials Science and Engineering

Ignitability Index	0
Spread of flame index	0
Heat evolved index	0
Smoke developed index	3

2.9 Thermal Resistance

BRANZ assessed the Thermal Resistance of the Unitex Base Board® Cavity System in BRANZ Appraisal No. 758 (2011) as follows:

Table 4. Centre of Cavity R-values for Unitex Base Board® System from BRANZ Appraisal No. 758 (2011)

Grade of Expanded Polystyrene	Assumed k-value @ 23 °C w/m, °C	Thickness (mm)	R-value m ² °C/w	Unitex Base Board® Cavity System, Centre of Cavity R-value
M grade	0.041	50	1.22	1.71
SL grade	0.045	75	1.67	2.16
SL grade	0.045	100	2.22	2.71

2.10 Durability/Service Life

The Unitex Base Board® Cavity System is expected to have a serviceable life of at least 30 years provided the system is maintained and the renders and texture coatings are continuously protected by a weathertight coating and remain dry in service.

2.11 Maintenance

Regular maintenance is essential to ensure the performance requirements of the BCA are continually met and to ensure the maximum serviceability of the system.

Regular cleaning (at least annually) of the surface coating is required to remove grime, dirt and organic growth and to maximise the life and appearance of the coating. Grime may be removed by brushing with a soft brush, warm water and detergent. Solvent based cleaners must not be used.

Annual inspections must be made to ensure that all aspects of the cladding system, including the finishing system, base, render, flashings and sealed joints remain in a weatherproof condition. Any cracks, damaged areas or areas showing signs of deterioration which would allow water ingress must be repaired immediately. Sealant, coatings and the like must be repaired in accordance with the instructions of Unitex®. Sealant to be inspected yearly and when showing signs of gaps or severe deterioration, remove and reseal. Contact Unitex www.unitex.com.au for appropriate movement modulus 25% sealant.

2.12 Other Design Factors

Residential buildings clad with Unitex Base Board® System are not more than three storeys above ground floor level and/or 8.5 continuous metres above ground level. Appropriate fire barrier between second and third story i.e metal flashing separation and/or Unitex encapsulated Base Block as Barrier.

All EPS (polystyrene foam) exposed to the elements is full rendered. All Unitex Base Board EPS is made from fire-retardant EPS, as is world-wide practice. Builders, plumbers working with naked flame, welding etc, is only to be carried out after all exposed EPS is render coated.

Unitex® specified renders and specified Applied Texture Finishing systems are recommended to be applied only in temperatures above 10°C and below 35°C.

The surface over which Uni-Base Board® factory coated sheets are fixed is true and level within 3 mm tolerance over a 1 metre radius. When using a timber frame, the frame must be constructed in accordance with the Australian Standard AS 1684-2010. The same tolerances can be expected in the finished and coated Unitex Base Board® Cavity System.

The surface over which Uni-Base Board® factory coated are horizontally fixed with staggered joints is through an H grade EPS cavity batten of 20-25 mm thickness over a frame (timber or steel) pre-wrapped with sealed breathable building wrap (sarking).

Unitex Base Board® Cavity System is not cleaned, painted or otherwise treated with materials containing hydrocarbon solvents. This requirement applies both during construction and occupancy.

Nil raw EPS is to be left uncoated/exposed in the finished installed system including around the base of walls.

Where the building is required to be protected from subterranean termite attack, a barrier system that complies with the requirements of AS 3660.1-2014 “Termite management – New building work” and is compatible with the building structure incorporating Unitex Base Board® System, shall be used.

Regular use of expansion / contraction joints is essential.

Cap flashings must project approx. 10 mm past the finished coated surface and right angle return well down pressing against the finished wall surface to create a drip line away from the wall. The minimum return dimension should be 50 mm (excluding drip edge) for wind zones N1 and N2, and 70 mm (excluding drip edge) for N3 to prevent water flow back.

The use of Unitex Base Board® Cavity System in an Alpine environment for resisting snow loadings against the walls has not been tested and is not a recommended use for the System.

3. Materials used in the Unitex Base Board[®] System



Unitex[®] supplies all the following materials to be used as components of the Unitex Base Board[®] System:

1. Uni Base Board[®]
2. Unitex[®] Cavity Closer
3. Unitex[®] Levelling Base Block (or use aluminium starter channel)
4. Unitex[®] Cavity Battens
5. Uni-Screw[®]/Washer Fixers (Mushrooms)
6. Unitex[®] Adhesive Foam
7. Unitex[®] Polymer Render
8. Uni-Mesh[®] IM 250
9. Uni-304[®] Angle
10. Uni Dry Cote[®] BBR (Base Board Render)
11. Uni-Shape[®] Sealant
12. Unitex[®] Applied Texture Finish such as Uni-Trowel Décor[®]
13. Uni-PTC[®] exterior surface coating
14. Unitex[®] Wedge Head Protector

3.1 Uni-Base Board®

Unitex® manufactures Uni-Base Board® on a dedicated coating line in Dandenong, VIC, Australia. Using Expanded Polystyrene (EPS) sheets as a raw material, the boards are meshed, coated and dried. Being cement and resin based, the coating displays excellent adhesion to the EPS sheet, has hard, tough and durable exterior properties combined with the flexibility needed for long term coverage of the EPS sheet. The coating incorporates a layer of alkali resistant fibreglass mesh that adds mechanical impact resistance and strength properties to the coating. The Unitex® developed ribbed surface profile of Uni-Base Board® aids the adhesion of render to the Base Board and assists applicators in building the render to the specified thickness where optimum performance is found.

Uni-Base Board® is an insulating product with thermal resistance (R value) increasing with the thickness of the sheet and the density of the sheet. Unitex® supply Uni-Base Board® with three thicknesses of EPS:

Table 5. Range of Uni-Base Board® products in Unitex Base Board® Cavity System

Thickness (mm)	Length x Width (mm)	Grade of EPS used	Nominal Density of EPS (kg/m ³)
50	2400 x 1200	M grade	19
75	2400 x 1200	SL grade	14
100	2400 x 1200	SL grade	14

The insulation sheet is manufactured from fire retardant “SL and M” grade Expanded Polystyrene (EPS) to AS 1366 “Rigid cellular plastics sheets for thermal insulation” Part 3-1992 “Rigid cellular polystyrene-moulded (RC/PS-M)” (Amdt 1 February 1993). The manufacturer regularly tests Cross Breaking Strength and Compressive Strength (mechanical properties) as part of their Quality Assurance. An extra requirement from Unitex® is a minimum bead fusion of 50% for extra strength.

Uni-Base Board® provides the builder/designer with a controlled surface for further application. For peace of mind, if the installed Uni-Base Boards are not able to be further coated for prolonged periods, or prior to typical EPS UV degradation, the pre-coated face will protect the boards until such time as it is possible to fully complete the coating steps.



3.2 Unitex® Cavity Closer is a perforated aluminium angle with an L shape that is attached to the frame at its base/plate and allows water to leave the cavity whilst keeping vermin from entering the cavity. Perforations are minimum 1000 mm² per lineal metre of wall. It is stalled what will be the cavity behind the Unitex Base Board



3.3 Unitex® Levelling Base Blocks provide a suitable base for laying Uni Base Board® onto. These are manufactured by Unitex® from lightweight concrete with embedded fibreglass mesh and an SL grade EPS insert and are used in conjunction with the Unitex® Cavity Closer at the base of the wall. **Unitex® Levelling Base Blocks** are supplied in 2400 mm lengths and provide a weather resistant, termite barrier ready start to the base of a wall clad with Unitex Base Board® Cavity System. Termite protection systems to be installed by builders approved suppliers. The Base Board levelling blocks are required in BAL-29 projects, in place of aluminium starter channels.

Unitex® Levelling Base Blocks are an edge coated starter support that both provides a tough, durable, sealed and level edging so that Uni Base Board® sheets are not exposed to the elements and prevents moisture ingress and general trade careless damage, near ground level.



3.4 Unitex® Cavity Battens are lengths of H grade EPS of 20-25 mm thickness and dimensions of 40 x 2400 mm. H grade EPS has a density of 24 kg/m³.

These are used to separate the building wrap (sarking) covered frame from the Uni Base Board® and thus form a cavity in the wall. Unitex® Cavity Battens are light tacked with corrosion resistant Class 3 or 4 tacks or adhesively fixed.



3.5 Uni-Screw/Washer Fixers (Mushrooms)

For walls with a cavity, the fixers (or fasteners) for both **Uni-Base Board®** and **Unitex® Levelling Base Blocks** shall be Unitex® supplied and specified corrosion resistant Class 3 screws of 3.55 mm diameter with bugle heads with lengths being minimum 50 mm greater than the thickness of the EPS sheet. Thus for 50 mm EPS sheet, fixing screws of 100 mm length shall be used, 125 mm screws for 75 mm EPS sheets and 150 mm screws for 100 mm sheets. This allows for screwing through the EPS sheet, 25 mm through the EPS battens, **a pull up of approx. 5 mm into the sheet** and approx. 25-30 mm for penetration into the timber frame. Self-tapping fasteners also of the same Class 3 corrosion resistant steel with the same lengths are used for steel frames.

The coating on each screw shall conform with AS 3566.2 - 2002 Table 2, corrosion resistance Class 3, which can be mechanically plated zinc/tin at a thickness of 25 microns or suitable corrosion inhibited coatings. For installations within 1 km of breaking surf or less than 100 metres from salt water not involving breaking surf, or in heavy industrial areas, either fixing screws that comply with corrosion resistance Class 4 or stainless steel (grades 316 or 316L only) shall be used. In all Base Board cases (but not the Base Blocks) the screws must be fitted with 50 mm diameter Unitex® blue HDPE plastic washers that support the EPS sheets to the frame and adhesively lock into the render system. All fixing centres are to be strictly set out as detailed in Table 1 to comply with the specified wind zone.

All cladding fixings shall be screwed so they sit 5 mm indented into the surface of the sheets.

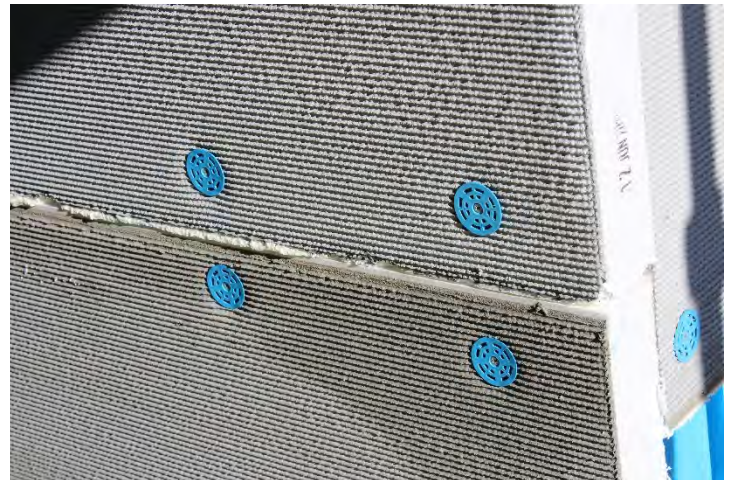
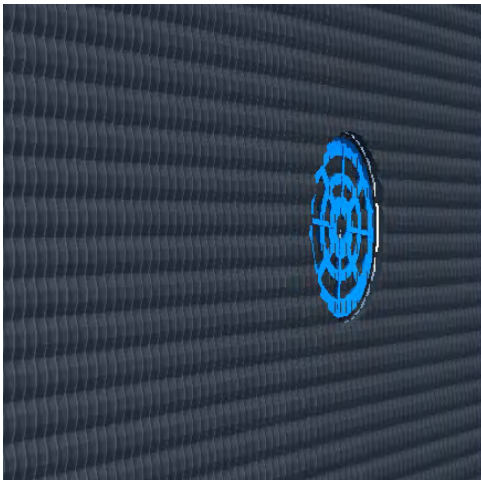

3.6 Approved Adhesive Foam is applied between **Uni Base Board®** sheet to sheet junctions. These foams include **Fula Foam** (H.B. Fuller) and **Touch'n'Seal Gun Foam II** as supplied by Unitex®. These adhesive foams are of PUR (polyurethane) basis and are compatible with EPS.

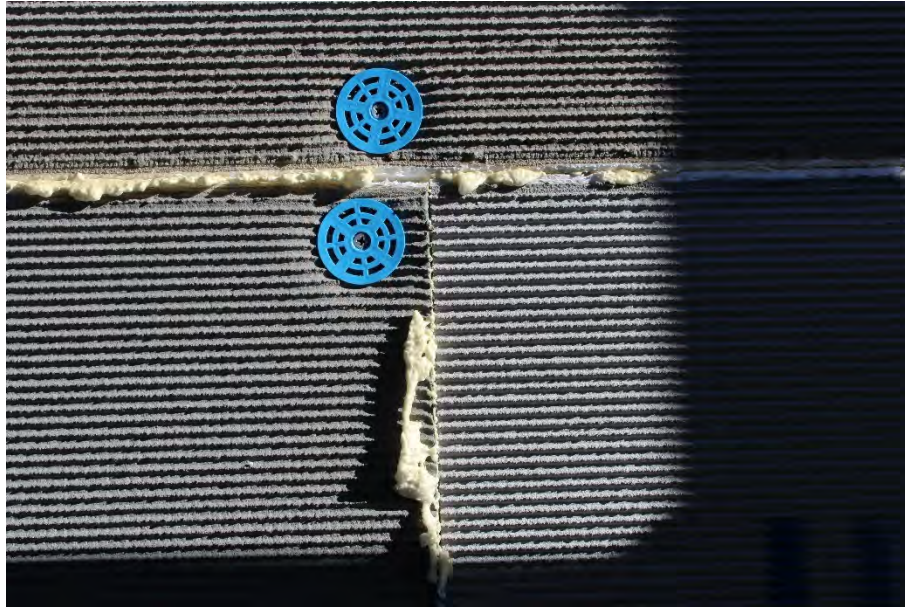

Note: The weather tightness of the **Unitex Base Board® Cavity System** may be compromised if excess adhesive foam has oozed from the junctions behind **Uni Base Board®** into the wall space or cavity. In damp conditions, water droplets may form on the oozed foam and drips may fall onto timber framework. Care must be taken to limit excess foam spilling from joints into the rear cavity.

3.7 Unitex® Polymer Render, with 5-10% Portland cement added, is the recommended render for covering the surface of uncoated Uni-Base Board® sheets, all meshed areas such as board to board junctions, meshed corner angles and any fixer/washer heads. Also, the recommended render over uncoated EPS cut edges such as those around window openings, etc. is **Unitex® Polymer Render**.

Unitex® Polymer Render is available in 15 litre pails in paste form (and in 20kg sack, in powder form to be mixed with approx.. 4.5 litres of water) and is a polymer rich adhesive render product that needs 5-10% cement added (not for 20kg powder based) prior to use to form a water resistant, strongly adhering, hard and flexible coating that is applied by trowel at typical thicknesses of 3-5 mm.

3.8 Uni-Mesh® IM 250 is an alkali resistant coated fibreglass mesh that is used as reinforcing mesh embedded in **Unitex® Polymer Render** over uncoated areas of **Uni Base Board®** sheets and along all joints, edgings and corners. IM 250 is mesh with dimensions of nominally 5 mm x 5 mm, a density of 160 g/m³, a width of 250 mm and is available in 50 m rolls. The resin content (alkali resistant coating content) is 16 ± 2% and the tensile strength (in N/50 mm) is ≥1200 for warp and ≥1400 for weft.



3.9 Unitex® only approves **Uni®- 304 angles** (304 grade stainless steel) and **aluminium Exterior Render Angle Beads**. These angles are corrosion resistant and Unitex® Polymer Render will adhere to them. Prior to render, all corners are reinforced with **Uni-Mesh® IM 250** embedded in **Unitex® Polymer Render**. The Angle Bead is then adhesively fitted into place also with **Unitex® Polymer Render** (plus 5-10% cement added on site). Plastic external corner angle beads are not approved for the **Unitex® Base Board® Cavity System**. Premeshed aluminium angle beads are also used, and approved as supplied by Unitex.

3.10 The recommended render over factory coated Uni-Base Board® is **Uni Dry Cote® BBR (Base Board Render)**.

Forming part of the Unitex Base Board® system, **Uni Dry Cote® BBR (Base Board Render)** is a Portland cement based, polymer modified render containing light weight, high build non-flammable materials, a copolymer powder resin and proprietary additives. **Uni Dry Cote®** powder products are manufactured to stringent quality standards using high quality raw materials, all of which are blended to meet Unitex specifications. The Quality System in place at Unitex® is modelled on elements of the ISO 9001 - 2015 Quality System as adapted for the CodeMark™ Compliance System.

Uni Dry Cote® BBR (Base Board Render) provides the ideal base for the subsequent application of a variety of Unitex® Applied Texture Finishes and top coats. This product is applied at a 5 mm build directly over Uni-Base Board® but can be built up to 12-15 mm in a single trowel application when required, such as for achieving higher Bushfire Attack Levels.



3.11 Uni-Shape® Sealant is used to provide a flexible waterproof seal at expansion and control joints, window and door reveals, meter boxes and cable penetrations, etc. **Uni-Shape® Sealant** has a Polycarbonate basis and is durable, of elastic nature and is compatible with Unitex® specialty finishes systems. It can also be painted over with **Uni-PTC®** coating for surface colour uniformity.



3.12 A suitable **Unitex® Applied Texture Finish** must be rolled, trowelled or sprayed over the render. Either **Uni Décor®** decorative texture (coloured or uncoloured) or **Uni Dry Cote®** powder texture finish (white or pre-coloured) can be applied followed by **Uni-PTC®** protective top coat (coloured). Options are the pre-coloured paste products:

- | | |
|---------------------------------------|--|
| • Uni-Roll Décor® Texture 109 | fine-medium grade, roller dependent |
| • Uni-Roll Décor® Texture 110 | heavy-coarse grade, roller dependent |
| • Uni-Trowel Décor® Texture 105 | 2 - 3 mm scratch |
| • Uni-Trowel Décor® Texture 104 | 1 - 2 mm scratch |
| • Uni-Trowel Décor® Texture 107 | 0.5 – 1 mm scratch |
| • Uni-Trowel Décor® Texture 146 | fine trowel finish |
| • Uni-Trowel Décor® Texture 155 | medium trowel finish |
| • Uni-Trowel Décor® Texture 165 | rough trowel finish |
| • Uni-Trowel Décor® Texture 333 | fine sand finish |
| • Uni-Trowel Décor® Texture 500 | medium sand finish |
| • Uni-Trowel Décor® Texture 777 / 888 | medium trowel finish & other fine - coarse grades. |

Or dry powder off-white textures which are:

- | | |
|------------------------------|--|
| • Uni Dry Cote® texture 804 | 1 – 2 mm scratch |
| • Uni Dry Cote® texture 807 | 0.5 – 1 mm fine scratch |
| • Uni Dry Cote® texture 846 | fine trowel finish |
| • Uni Dry Cote® texture 855 | medium trowel finish and other fine to coarse grades. These grades are not pre-coloured. |
| • Uni Dry Cote Redi-Textures | |

Typical coverage rates are 10-12 m² per pail (15 litres) for fine to medium textures and 6-8 m² per pail for heavy grades of textures. With **Uni Dry Cote®** textures, typical coverage is 8-10 m² per bag.

Applied Texture Finishes typically contain carefully selected mineral particles that provide a texture effect, e.g. scratches, fine or coarse surface textured effects, etc. to the surface appearance of the wall.



3.13 Uni-PTC® is a suitable top coat for a desirable matt look.

Unitex recommends one coat of sealer and 2 coats of **Uni-PTC** to be applied over **Uni Décor® textures and Uni Dry Cote® textures**. In most commercial applications, up to 3 coats may be required.

3.14 Unitex Wedge Head Protector is a shape designed to deflect water from pooling on meter boxes within the cavity. It is manufactured from high density H grade EPS with density of 24 kg/m³. The Wedge Head Protector is illustrated in Section 4.2.6.

3.15 Additional Options from Unitex

Primers and sealers can be used to enhance the Unitex Base Board System. Primers from Unitex are **Unitex® Cembond** for highly absorbent surfaces or **Unitex® Substrate Sealer** for applying on less absorbent surfaces or in elevated temperatures. These polymer rich liquid products can provide a key for adhesion of **Uni Décor®/Uni Dry Cote® texture or Uni-Shape® Sealant** mastics to the render.

Uni-Shape Sill Blocks are fitted under windows providing rigidity and strength to a vulnerable area as well as directing water away from the window. These are manufactured by Unitex® from lightweight concrete with embedded fibreglass mesh and an SL grade EPS insert and are supplied in lengths to suit the window frame. Uni-Shape® Sill Blocks are optional but recommended inclusions in the Unitex Base Board® Cavity System. They are made with an 8 to 10 degree fall away from the window and to be fitted snugly (not squeezed tight), back under and behind the drain joint seal allowing free flow away of drained water.

3.16 Accessories used with the System which are **supplied by the building contractor** are:

1. Sarking

Kraft based paper complying with AS/NZS 4200.1 – 2017 or breather type membranes covered by a valid BRANZ Appraisal for use as wall wraps.

2. Sarking support

Polypropylene strap for securing the sarking in place and preventing bulging of the bulk insulation into the drainage cavity where cavity battens are installed at greater than 450 mm centres. Note: additional vertical battens may also be installed to provide support.

3. Flexible sill and jamb flashing tapes

Flexible flashing tapes complying with ICBO Acceptance Criteria AC148, or flexible flashing tapes covered by a valid BRANZ Appraisal for use around window and door joinery openings.

4. Flashings

Including window and door joinery head flashing, parapet cap flashings and horizontal joint flashings. All terminations and junctions must be adequately flashed which are compatible with the Unitex Base Board Cavity System and comply with AS/NZS 2904 - 1995.

5. Cavity batten fixings

30 or 40 x 2.5 mm hot dip galvanised steel flat head nails for timber frame, or construction adhesive for temporary fixing to sarking over timber or steel frame.

6. Waterproof membrane tapes

Tapes covered by a valid BRANZ Appraisal for use as waterproofing membranes over tops of plastered parapets, balustrades, fixing blocks and the like.

7. Window and door trim cavity air seal

Self-expanding, moisture cure polyurethane foam air seal for use around window, door and other wall penetration openings.

4. Installation Guidelines

4.1 This Technical Manual describes installing **Unitex Base Board® Cavity System** onto a breathable building (sarking) wrap covered frame.



Unitex® Levelling Base Block
Start by levelling and mechanically fixing the Unitex® Levelling Base Block to a suitable frame with breathable building foil (min. studs 600 mm centres). Use Uni-Screw/Washer Fixers at least 25 mm longer than the thickness of the Unitex® Uni-Base Board™ and fix to the base of the framing. (Non Cavity depicted)



Seal windows and measure openings
Seal windows to wrap with ducting/aluminium tape and apply Uni-Shape Sealant mastic to window frames as required. Where openings (windows and/or doors) penetrate the wall elevation, measure off wall and transfer these measurements to the Unitex® Uni-Base Board™. (Cavity depicted)



Cut Uni-Base Board to size
It's always a good idea to measure twice and cut once. After measuring the wall and marking-up Unitex® Uni-Base Board™, saw cut to size. Cut either manually or with an electric saw. All waste pieces and sawing scrap should be bagged and binned or returned to Unitex for reprocessing.



Fixing Uni-Base Board
Unitex® Uni-Base Board™ should be held securely to the studs of the framing. Install extra blocking and/or noggings if required so that the sheets are held firmly. Use eight (8) Uni-Screw/Washer Fixers per square metre. All sheet to sheet junctions are to fit snugly together with no open gaps.



Unitex® Uni-Base Board™ to Unitex® Uni-Base Board™ (return edges/sealing)
Once the first sheet has been fixed, apply Unitex® Adhesive Foam from a gun to all edges (front half of edge) of the Unitex® Uni-Base Board™ that come in contact with the next installed sheet. Ensure that there are no gaps between the sheets and that sheets are level.



Laying out Unitex® Uni-Base Board™
Stagger all joints as per a common bond brick pattern. At the corners, stagger the sheets, overlap as shown above. Corners may require extra studs for added strength and rigidity. Use extra Uni-Screw/Washer Fixers if required.



Sealing at windows
Apply Uni-Shape Sealant mastic to the rear of Unitex® Uni-Base Board™ adjacent to the window frame around the window. Cut Unitex® Uni-Base Board™ so that it is 5 mm clear of window frame and a minimum of 20 mm free of the frame at the window sill. Cut the window sill on an angle to allow for -10° slope/fall. Surface mastic sealing (see Diagrams 1A, 1B & 1C) or alternatively pre-made Uni-Shape™ Window Sill Blocks.



Window and corner protection
All windows and corners are to be extra reinforced with Uni-Mesh IM250 (250 mm) patches overlapping into reveals. The fibreglass mesh should return and cover the reveal and can be installed under or over the Uni-304 SS Angle/Alu Angle and into wall face for a minimum 125 mm. (In this case mesh is under the Uni-304 SS Angle/Alu Angle).



Edge protection for Uni-Base Board
(refer to the Unitex® Uni-Base Board™ System Technical Manuals for variations, at www.unitex.com.au or www.render.com.au)
All Unitex® Uni-Base Board™ edges are to be further protected with the Uni 304 SS Angle/Alu Angle embedded in Unitex® Polymer Render(5% - 10% cement). They must be full lengths from corner to corner and also overlap at the corners.



Reinforcing mesh to junctions
Unitex® Uni-Base Boards™ are supplied pre-meshed so all Unitex® Uni-Base Board™ to Unitex® Uni-Base Board™ junctions are to be like reinforced with Uni-Mesh IM 250 embedded in minimum 2-3 mm Polymer Render + (5% - 10% cement). The mesh should extend 125 mm on each sheet.



Mixing Uni-Base Board Render
(Apply when dry or minimum 24 hours after Unitex® Polymer Render application)
Unitex® BBR is supplied in approx. 8.5kg bags (Super Light Render). Simply add approximately 4 litres of clean water to a clean 15 litre pail and slowly add Unitex® BBR while drill mixing to form an homogenous mix (free of lumps). The render viscosity should suit a 5-10 mm build coat.



Applying Unitex® BBR
(Use a plastic or foam float/trowel)
Using a Hawk and Trowel or Render Spray Machine, apply Uni-Base Board Render evenly over the surface to the required depth (normally 5-10mm).
Note: Unitex® BBR is a medium build product, for a thicker high build system (up to 15+mm) apply a second coat over set Unitex® BBR.



Floating Unitex® BBR
As the Unitex® BBR surface sets, finish level with a plastic float to the exactness required to accept the next coat. Allow to set, dry and cure for 72 hours (min.) before applying a Unitex® Textured Finish. There are many grades and styles of Unitex® Textured Finishes available.



Unitex® Base Board window reveals
Window reveals to be coated to 7.5 mm depth (min). Sills should fall/slope approx. 8-10° to prevent water flowing back. Window sill rubber flap (supplied with window) needs to remain clean, free and intact. Note: Unitex® supplies pre-made Window Sill blocks to simplify this process. Always protect and cover the adjoining surfaces before application.



Expansion and Control Joints
Unitex® Uni-Base Board™ is either direct fix or cavity fix to an existing frame or surface. Expansion and control joints are essential in all Unitex® Uni-Base Board™ Systems and are recommended at a maximum every 6-8m and between floor levels. After internal fit-out extra movement joints may be required.



Unitex® Textured Finishes over Unitex® Uni-Base Board™. Apply when fully dry (or min. 72 hours) after Unitex® BBR. Uni-Trowel Décor is an easy to apply textured and pigmented surface applied finish. The Unitex® Uni-Cote range of powder-based Textured Applied Finishes can be used. Note: These must be suitably over-coated with Unitex® Uni-PTC (Or Unitex® Uni-Flex Membrane) pigmented sealing surface finishes (refer to Unitex® Renders and Finishes Manual).



Proven system – technical back-up
Freecall 1800 647 374 and a Unitex technical representative will provide a no obligation quote. Unitex® can recommend an Accredited Installer for you to select.

A Unitex technical representative is on call to visit your site and advise on correct installation, texture and colour, as well as warranty sign off.



Unitex® Uni-Base Board™ for peace of mind

Unitex® Uni-Base Board™ when installed as above (in accordance with the Unitex® Uni-Base Board™ System Cavity and Non-cavity Technical Manuals – available on www.unitex.com.au, www.render.com.au) is fully accredited via BRAC, BRANZ and CodeMark for your total peace of mind. Unitex® Uni-Base Board™ is quick and easy but does require a team effort:

- Quality Substrate (by Builder)
- Accredited highest quality System (Unitex®)
- Experienced Accredited Tradespeople (to install and finish)

When the job is done right, Unitex® backs-up the Unitex® Uni-Base Board™ System with a 7 year warranty.

Note: With features such as meter boxes, balustrades, parapets, downpipes, cabling, fixtures, etc. and penetrations through the Uni-Base Board®, see separate detailed instructions below.

4.2 Detailed Installation Instructions

4.2.1 Breathable Building (Sarking) Wrap

All framing exterior surfaces shall be covered with a breathable type building wrap (sarking) recommended by the manufacturers as suitable for use in a single skin system. The sarking can either be a kraft-based paper complying with AS/NZS 4200.1-2017 or breather-type membranes covered by a valid BRANZ Appraisal for use as wall wraps. Sarking must be installed horizontally and continuous around corners, and must be overlapped 75mm minimum, upper layer over lower layer at the horizontal joints, and 150mm over studs at vertical joints. Unitex® does not supply building wrap (sarking). The building wrap must be fixed to the framing in accordance with the building wrap manufacturer's specifications. Sarking support, usually a polypropylene strap, is used for securing the sarking in place and preventing bulging of the bulk insulation into the drainage cavity where cavity battens are installed at greater than 450 mm centres. (Note: additional vertical battens may also be installed to provide support.) The building wrap shall be taken into all joinery openings and fastened to the outer face of the framing.



Sarking is installed with top wrap overlapping the lower wrap and sealed with an approved flashing tape. Flexible sill and jamb flashing tapes shall either comply with ICBO Acceptance Criteria AC 148 or be covered by a valid BRANZ Appraisal for use around window and door joinery openings. Sarking to penetrations must also be sealed with flashing tape. Head, jambs and sill junctions shall be adequately overlapped and an approved flashing tape used to cover these internal junctions.

4.2.2 Seal windows, all penetrations and measure openings

Seal all the building wrap with flashing tape around windows, doors and all penetrations, etc. To windows only, apply **Uni-Shape® Sealant** to the rear of the window frame drain joints. Ensure drain joints and sealing rubbers on windows are free (not squeezed) and are able to function. Where openings such as windows and doors penetrate the wall elevation, measure off wall and transfer these measurements to the **Uni Base Board®**.

4.2.3 Install Unitex® Cavity Closer to the base of the frame

The vented aluminium cavity closer must be installed first by tacking it onto the timber bottom plate as a level starter. Ensure that the tacks are Class 3 corrosion resistant or, for marine or heavy industrial areas, Class 4 corrosion resistant steel or stainless steel (316 or 316L grades only). Seal the Unitex® Cavity Closer to the building wrap with flashing tape.

4.2.4 Place 20-25 mm thick Unitex® Cavity Battens in front of studs from Unitex® Cavity Closer to top of wall

All exterior wall surfaces shall be battened using **Unitex® Cavity Battens**. These are strips of H grade EPS with thickness 20-25 mm, width 40 mm and length 2400 mm). To all studs, lightly tack a cavity batten to the full length of the stud with all joints tight butted. The battens must be centred on the timber studs. Additional vertical battens are also required at internal and external corners, openings and a continuous horizontal batten at the soffits for fixings; gables must also be lined or incorporate an air barrier to prevent air flow into the roof.

Where penetrations may interfere with battens, parts of the battens may be removed to make way for the penetrations.

Noggins, depending on fixings set up (see Table 1.), require a cavity batten packer offset at a minimum 5° slope and with a minimum 50 mm gap at the vertical batten transitions. Additional horizontal spacers are required at the head and sill for support and the cavity is to be limited to two storeys plus gables. Construction of three storey buildings requires the cavity to be closed with an inter-storey metal flashing between the second and third storey.

Unitex® prefers the cavity closed at each floor level with appropriate flashing to carry any water/moisture out to the floor level flashing exit joint.

TYPICAL BATTEN LAYOUT

Source : BRANZ

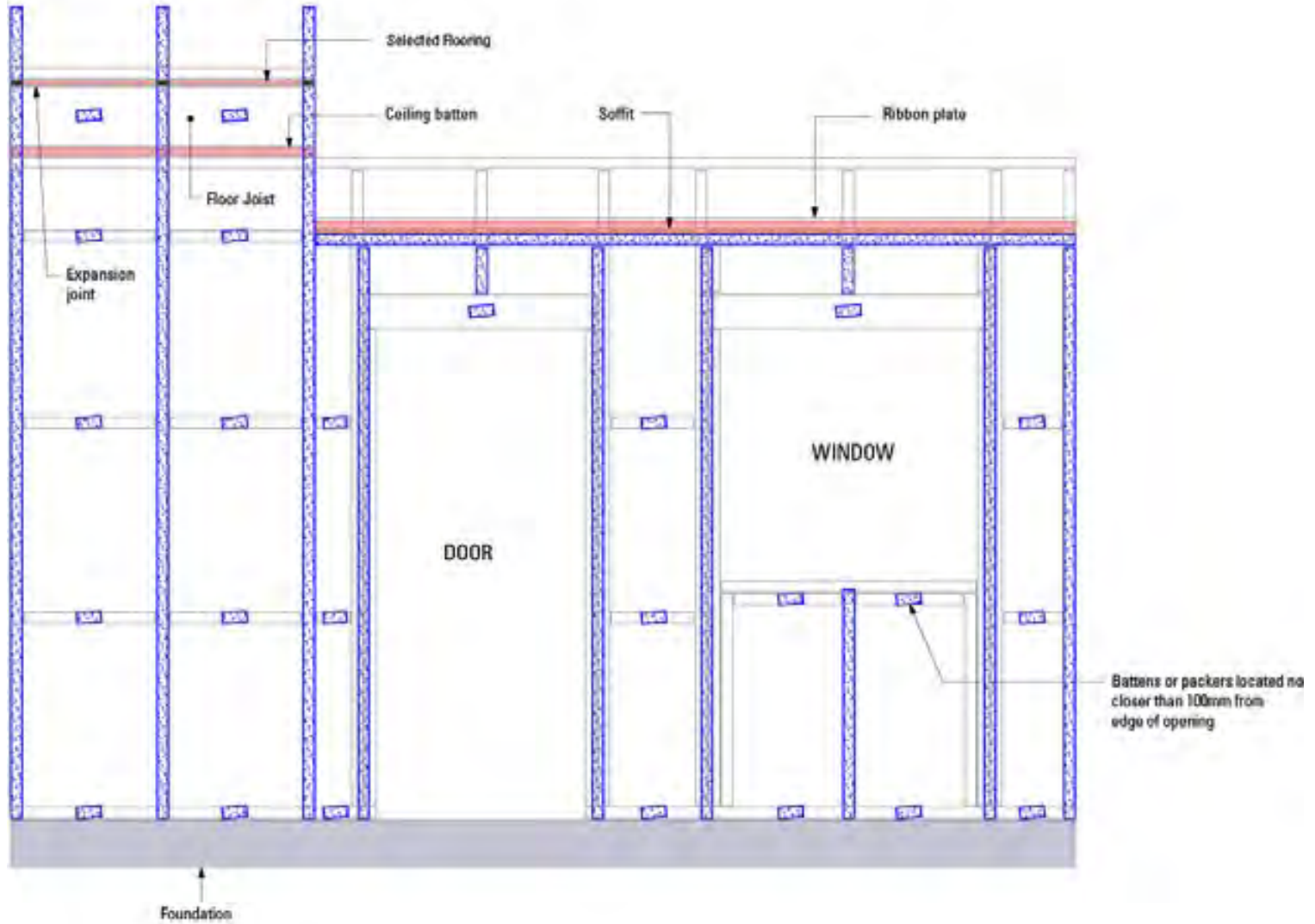

NOTES:

- If additional wall insulation is being installed, the sarking must be supported by polypropylene builders strap stapled horizontally along the wall at 300mm vertical centres to stop the wrap bulging into the cavity
- All horizontal battens must be applied on a minimum slope of 15 degrees and be no longer than 100mm in length. (only one horizontal packer may be placed between vertical battens)

4.2.5 Install Unitex® Levelling Base Block to base of wall

Start by levelling and mechanically fixing the **Unitex® Levelling Base Block** to the base plate of frame with building wrap (sarking) in place. Ensure that there is a 5 mm gap at the base of the cavity to allow for ventilation and drainage of the cavity. Use fixer/washers at least 50 mm longer than the thickness of the **Uni Base Board®** and fix to the base of the framing. As **Unitex® Levelling Base Blocks** are rigid, screws without washers usually provide adequate fixing.

Ensure that soil and paving is not in contact with the base of the wall. A 100 mm clearance to paved ground and 175 mm clearance to unpaved ground is recommended.

Unitex® Uni-Base Board™: Slab at ground

Unitex® BBR (5-15mm depending on which system) and Unitex supplied finish system (Unitex Texture and Uni-PTC).

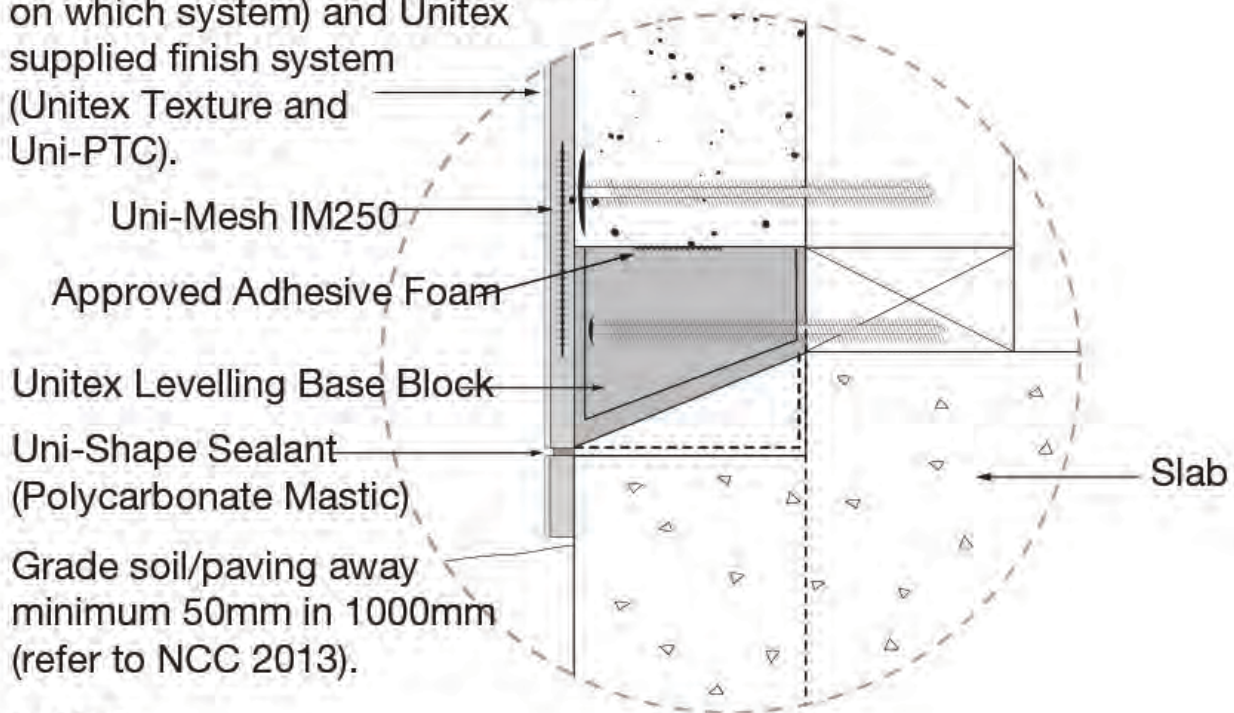

Grade soil/paving away minimum 50mm in 1000mm (refer to NCC 2013).

NOTE:

1. Termite protection by builder (and/or 75mm clearance).
2. Do not backfill over Uni-Base Board.
3. Slab to conform to local regulations.

4.2.6 Install Unitex® Sill Blocks (optional) to windows and Unitex® Wedge Head Protector to meter boxes



Unitex® manufactures a range of **Uni-Shape® Sill Blocks** which consist of lightweight concrete with EPS inserts in the shape as shown above. The sill provides strength and rigidity to the area below a window that is otherwise vulnerable to impacts and weight loadings from time to time, as well as having a shape to direct rain away from the window. Sill Blocks can be sawn to the correct length and are fitted true and level under the window as shown and are offered as a pre-made and easier alternative to on-site reinforced Unitex® render application. Fixing by screws alone are through the sill block, the batten, through the builders wrap and into the frame stud. Washers are usually not needed as the sill block has a rigid construction. **Uni-Shape® Sealant** is applied behind the rubber strip on the base of the window.



Unitex Base Board Cavity System: Sloping Head Drainage for Meter Box and other penetrations

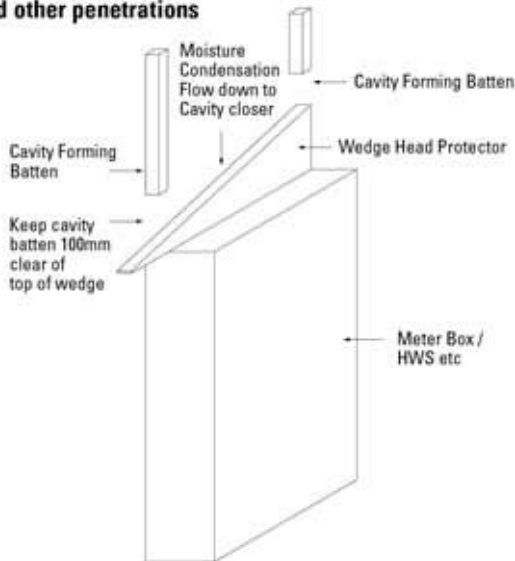

For penetrations such as meter boxes, the use of a Unitex® Wedge Head Protector EPS insert with a triangular profile with angles of greater than 10° is recommended. The base of the wedge is placed in the cavity above the meter box and fixed to the frame. The aim of the Unitex® Wedge Head Protector is to direct water and moisture in the cavity away from the top of the meter box and thus prevent water pooling or from entering the meter box.

4.2.7 Rubbish Removal

It is always a good idea to measure twice and cut once. After measuring the wall and marking up **Uni-Base Board®**, saw cut to size when wearing the appropriate Personal Protection Equipment (including dust masks). Cut either manually or with an electric saw.

All waste pieces and sawing scrap should be bagged and binned or returned to Unitex® for reprocessing.



4.2.8 Fixing Uni Base Board®



Approved Adhesive Foam shall be placed on the front half of the **Unitex® Levelling Base Block** ensuring that no foam oozes onto the back half or into the cavity. **Uni-Base Board®** should be placed on the **Unitex® Levelling Base Block** from a corner of a building and abutted firmly. Excess adhesive foam must be wiped away, especially any oozing into the cavity. Each sheet must be fixed with a **Unitex® supplied screw/washer®** through the **Unitex® Cavity Batten** and the breathable building wrap (sarking) and into the studs of the framing. Please remember to use **Unitex® screw/washers** that are 50 mm longer than the thickness of the **Uni Base Board®** grade being used. Install extra back blocking and/or noggins if required so that the sheets are held rigid and firmly. Use at least eight (8) **Uni-Screw®/Washer** Fixers per square metre. Consult **Table 1** for maximum Fixer spacings when in areas prone to high winds but note that this **Unitex Base Board®** Cavity System is not suitable in areas frequented by tropical cyclones. All sheet to sheet junctions are to fit snugly together with no open gaps.

4.2.9 Apply adhesive foam between Base Boards

Once the first sheet has been fixed, apply Unitex® approved Adhesive Foam from a gun to the front half of all edges of **Uni Base Board®** that come in contact with the next installed sheet. Ensure that there are no gaps between the sheets and that all sheets are level. Make sure that any foam does not ooze behind the sheets.

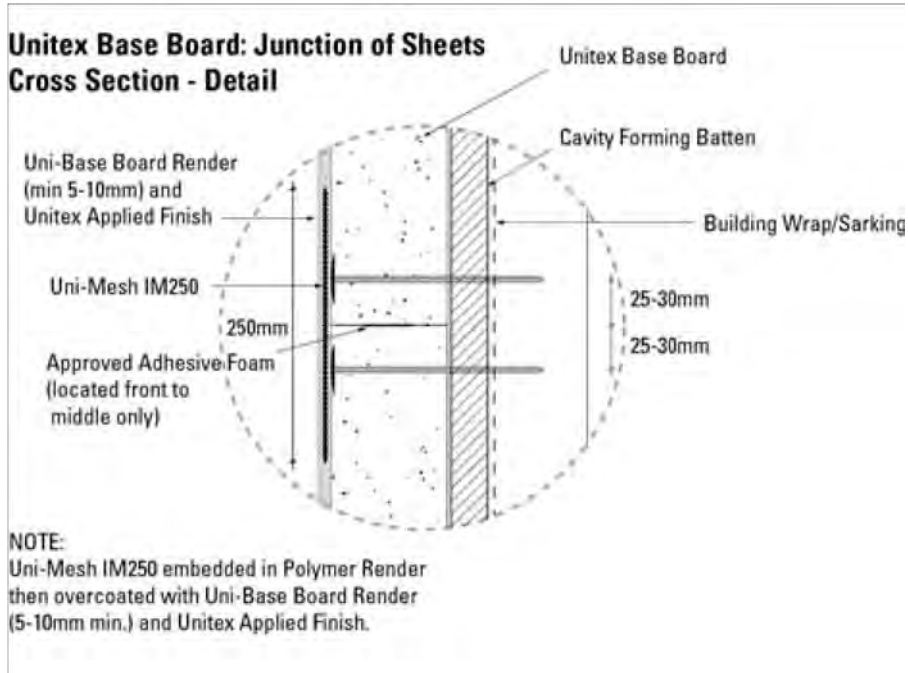

4.2.10 Laying out Uni Base Board®

The **Uni Base Board®** sheets are to be installed horizontally across a minimum of 4 studs. Install sheets from bottom to top and stagger all joints as per a common bond brick pattern. At the corners, stagger the sheets and overlap them. Corners require extra studs for added fixing strength and rigidity. Use extra **Uni-Screw®/Washer** Fixers (mushrooms) if required.

Keep a part of each cavity batten above the level of the sheets so that fixing through the batten into the frame is straight forward.



Uni-Base Board Fixing to Wrapped Frame - Front Elevation

Frame/Bracing by Builder

Max 600 mm Centres (or refer AS 1684.1-2010)

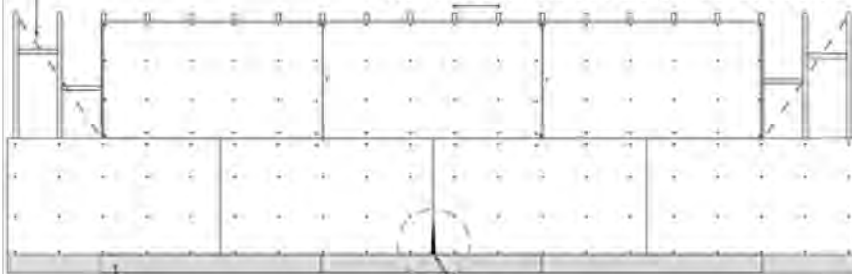

Work from Unitex Levelling

Base Block upwards

General Fixings $\approx 8/m^2$

(consult wind load tables for fixer spacings)

Fill Gaps (if required)

NOTES:

1. Uni-Base Boards to be fixed horizontally with staggered joins (common brick pattern)
2. Do not fix sheets vertically
3. Screw Uni-Base Board through Cavity battens to wrapped frame

All washer/screw heads embedded by approx. 5 mm into **Uni Base Board**[®] must be flush stopped with **Unitex**[®] **Polymer Render** (with added cement) and made level with the surrounding Base Board. This provides a level surface for subsequent application of renders, protection against corrosion for the screw and ensures that washers will not be seen under subsequent layers of render and texture finishes.



4.2.11 Sealing at windows

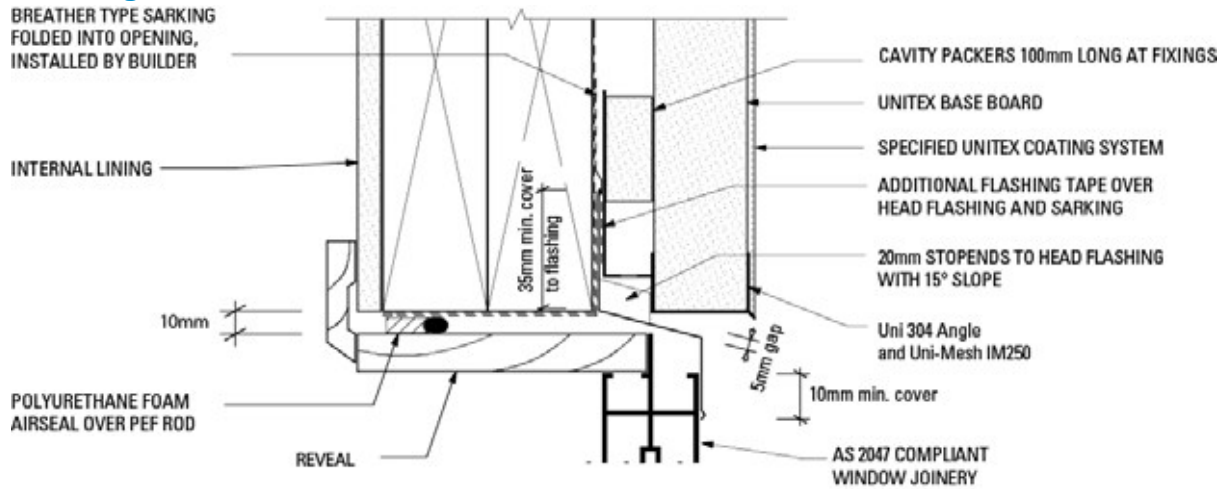

WINDOW HEAD - CAVITY

Source : BRANZ

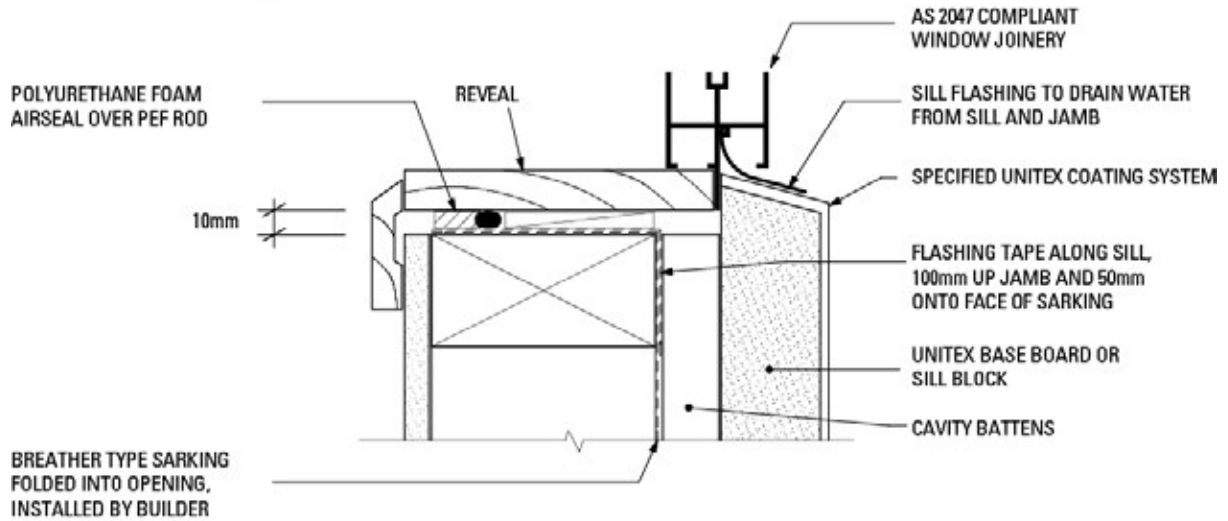

WINDOW SILL - CAVITY

Source : BRANZ

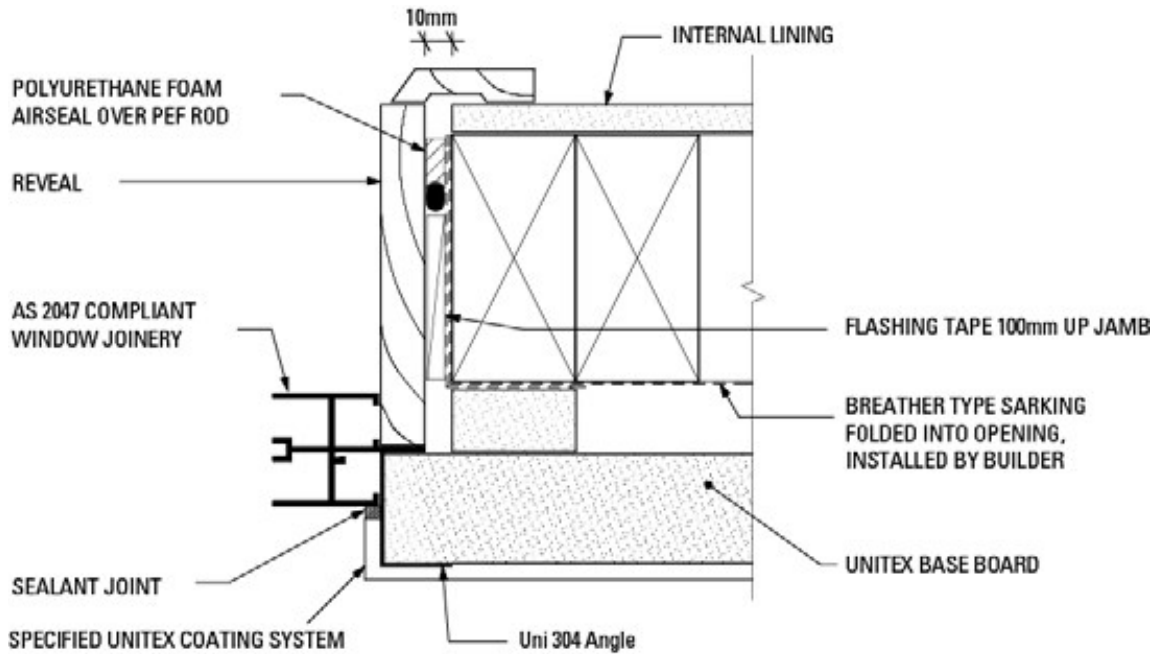

WINDOW JAMB - CAVITY

Source : BRANZ

Protection of adjoining surfaces (with tape and clear plastic film, etc.)

Head flashings above penetrations – The cavity above penetrations, e.g. windows, needs to be able to drain and vent. This is best achieved with the use of a head flashing for the window joinery.

When installing an awning type window, apply **Uni Shape® Sealant** to the rear flat of the window C section drain joint, in effect to the rear of **Uni Base Board®** adjacent to the window frame around the window. Cut **Uni Base Board®** so that it is 5 mm clear of the window frame and a minimum of 20 mm free of the frame at the window sill. Cut the window sill on an angle to allow for a minimum 8° slope/fall away from the window. For larger sills, a 10-30° slope is recommended (be mindful of aesthetics).

4.2.12 Window and Corner protection



All window heads and sills, architrave leading edges and external building corners are to be extra reinforced with **Uni-Mesh® IM 250** patches overlapping into reveals. The fibreglass mesh should return and cover the reveal and can be installed under or over the **Uni-304® Angle** or Aluminium angles and into the wall face for a minimum 125 mm. Embed the fibreglass mesh into **Unitex® Polymer Render**, modified with 5-10% Portland cement.

Uni-Base Board: Window Edge Reveal - Detail

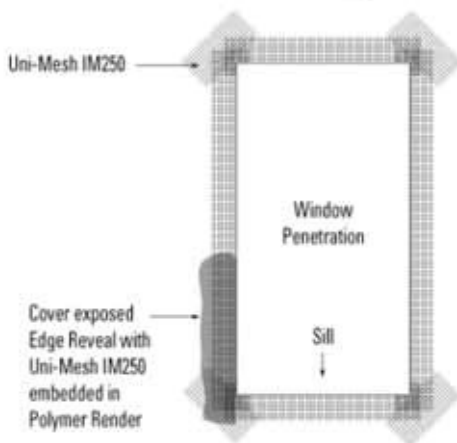

NOTES:

1. Extra Uni-Mesh IM250 reinforcing to all corners doors/windows
2. Control joints always advised to window/door at stress points

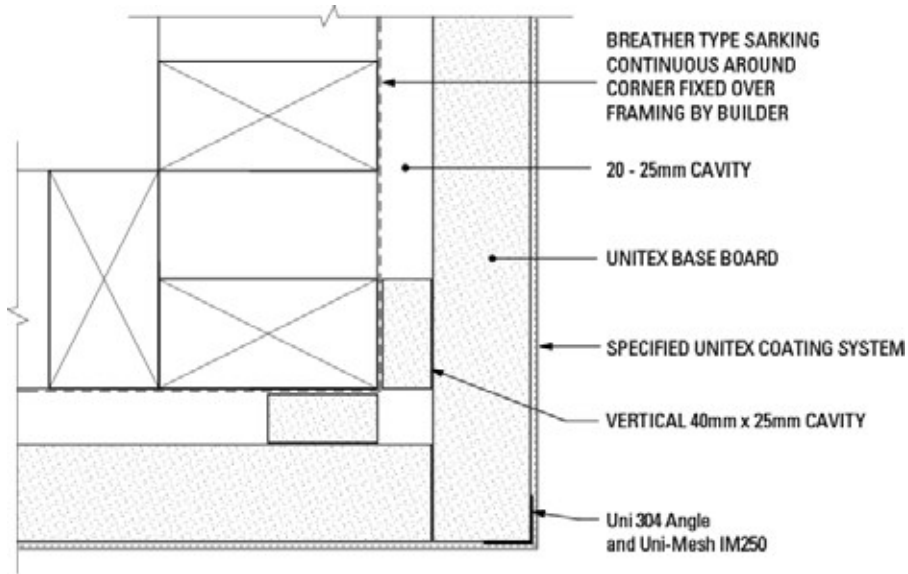

EXTERNAL SQUARE CORNER - CAVITY

Source : BRANZ

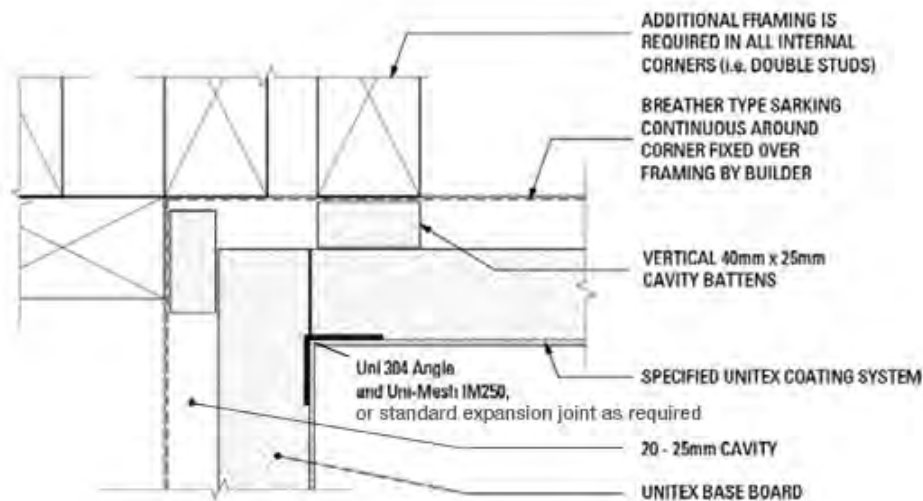

INTERNAL SQUARE CORNER - CAVITY

Source : BRANZ

4.2.13 Substrate Preparation

Areas not to be coated should be masked and protected, e.g. windows, roofing, down pipes, paving, etc.

All surfaces to be rendered must be dry and clean, stable and free from surface contaminants including: ultra violet degraded EPS (seen as yellowish powder residue), oil, mould release, other dusts, dirt, mud, and any loose or flaking material.

4.2.14 Application

Tools etc. required: power drill/mixer, laying-on trowels and hawk, floating (rubbing) and sponging trowels of plastic or polystyrene, spirit level, straight edge, masking tapes, cutting tools, grinder/discs, mastic gun, paint roller, brushes, plastic and/or material drop sheeting and 3-ply timber sheets for roof protection. Render pumping machinery (type with separate mixing and pumping processes) is optional.

Check that **Uni Base Board**® sheets have been installed securely and correctly.

Factory coated **Uni Base Boards**® are supplied pre-meshed so all **Uni Base Board**® to **Uni Base Board**® junctions are to be reinforced with **Uni-Mesh**® **IM 250** embedded in minimum

2-3 mm **Unitex**® **Polymer Render** (with 5-10 % added cement). The mesh should extend 125 mm approx. on each sheet. All screw washer heads (depressed in surface approx. 5 mm) should be coated with **Unitex**® **Polymer Render** (cement added). This creates a total surface reinforced render envelope prior to expansion (control) joint installation.

Mix 5-10% Portland cement into a pail of **Unitex**® **Polymer Render** with a power drill/mixer. Apply a 5 mm layer of **Unitex**® **Polymer Render** (with cement added) over all washer/screw heads, all sheet to sheet junctions and around all bare EPS at corners and penetrations such as doors, windows, etc. using a steel trowel and whilst the render is wet, embed a layer of **Uni-Mesh**® **IM250** alkali resistant fibreglass mesh ensuring that mesh pieces are overlapped by a minimum of 100 mm.



During application and drying of the render, the rendered walls and sub-frame must not be interfered with by other trades until set and drying is completed (no hammering, drilling, vibration of walls, etc.).

Wait 72 hours and test for moisture content with a hand-held Moisture Meter. If the reading is 12% Wood Moisture Equivalent or below, thorough drying has occurred and the overlaying render can be applied. If the reading is above 12% WME, wait more time until the surface is suitably dry. Unitex® uses and recommends the **GE Protimeter Surveymaster moisture meter**.

4.2.15 Importance of thorough drying

Generally, the substrate must be dry before application of the render. Likewise, the render must be dry before a texture is applied over the render and similarly, the texture must be dry before a topcoat such as **Uni-PTC®** is rolled over the texture. It is the responsibility of the Builder and/or Contractor to ensure that each surface (including substrate) is thoroughly dry before the next coat (render, primer/sealer, texture or topcoat) is applied. Unitex® recommends that professional contractors use a Moisture Meter to determine the degree of dryness. Building Inspectors consider dry conditions to be consistent with readings of less than 12% WME (Wood Moisture Equivalent). Wet and cool conditions and also tropical wet and humid conditions present the most challenging weather conditions to achieve dryness levels suitable for overcoating. Should a coating be applied on a substrate or surface that has not sufficiently dried, sometimes a white bleaching, blistering and/or cracking on the surface may occur in the weeks after application as moisture slowly evaporates out of the system.

4.2.16 Edge protection for Uni Base Board®



All **Uni Base Board®** edges are to be further protected with the **Uni-304® External Angle Bead** (304 grade stainless steel) or aluminium angle beads embedded in mesh reinforced **Unitex® Polymer Render** (with 5-10% added cement). They must be full lengths from corner to corner and also overlap at the corners.

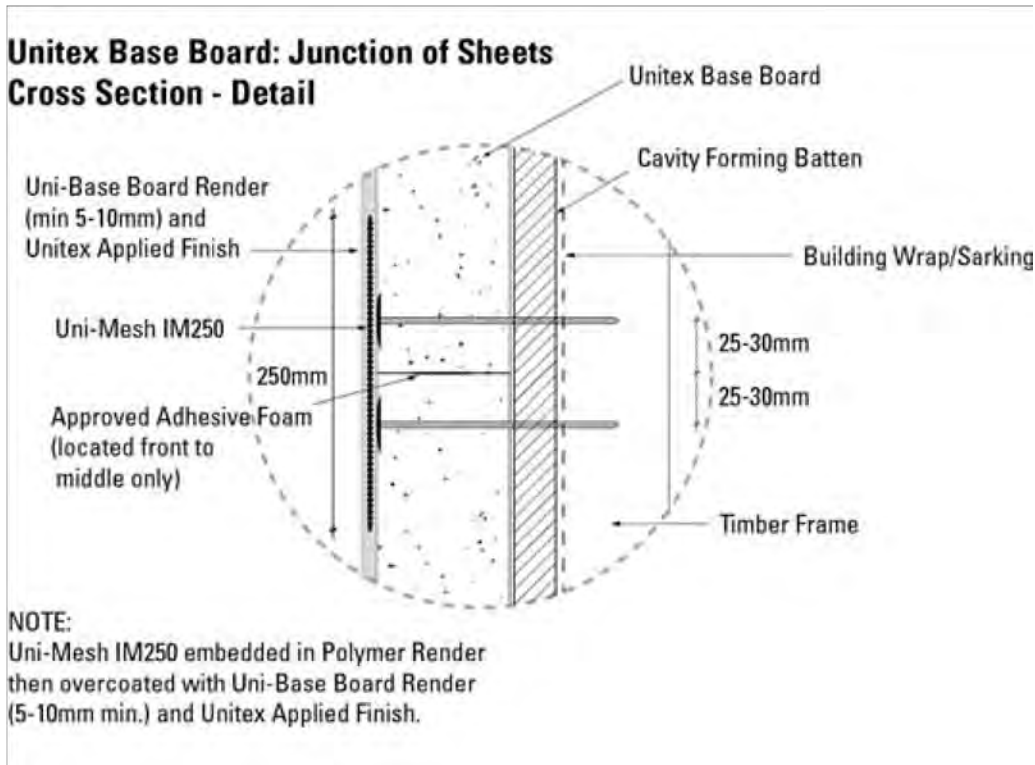



4.2.18 Mixing Uni Dry Cote® Base Board Render



After **Unitex® Polymer Render** has thoroughly dried (see **4.2.15 Importance of thorough drying**), the surface can be coated with **Uni Dry Cote® Base Board Render**. This is a specialty polymer modified purpose made product that adheres to the factory applied reinforced render that pre-coats the EPS sheets.

Uni Dry Cote® Base Board Render is supplied in 15 litre bags. Add approximately 4 litres of clean water to a clean 15 litre pail and slowly add **Uni Dry Cote® Base Board Render** powder while drill mixing to form an homogeneous mix free of lumps. Adjust the render viscosity with more or less Render to achieve a slump to allow a uniform coating thicknesses of 5-10 mm. Allow the mix to stand for 5 minutes then remix and adjust the consistency if required.

4.2.19 Applying Uni Dry Cote® Base Board Render



Using a Hawk and Trowel or Render Spray Machine, apply **Uni Dry Cote® Base Board Render** evenly over the surface to the required depth. A 5 mm build is normal plus at least 5 mm is recommended to cover all screw washer heads. From time to time, additional impact protection, especially on ground floors, is needed or when levelling of **Uni Base Board®** sheets is necessary such as when correcting earlier minor uneven levelling faults, builds up to 10 mm may be required. This can be achieved with either 1 or 2 coats of **Uni Dry Cote® Base Board Render**.

4.2.20 Floating Uni Dry Cote® Base Board Render

Before the render has surface dried, floating with a polystyrene or plastic float must be carried out to smooth out the surface. Render coats are hand finished and some variation is usually acceptable as long as these variations are not more than 3 mm per metre radius. Hence it is important that the Base Boards have been prior installed relatively true and level. This is the Builders responsibility to provide an acceptable frame that is packed out where necessary.

Allow the render to set and cure for 72 hours before measuring the WME (see **4.2.15 Importance of thorough drying**). If below 12% WME, a Unitex® Applied Texture Finish can be applied. There are a number of grades available from a sandy effect to rough cast and scratch effects (see **Section 3. Materials used in the Unitex Base Board® system** above).

4.2.21 Uni Base Board® window reveals



Window reveals shall be coated with **Uni Dry Cote® Base Board Render** to 5 mm depth. Sills should fall or slope at least 8° away from the window to prevent water flowing back. The window sill rubber flap (supplied with the window) needs to remain free, clean, firm and intact. It is good practice to protect other surfaces (glass, frames, tiles, pavers, etc.) with plastic, paper or a peel-off coating before applying render and finishes.

4.2.22 Expansion and control joints

Unitex Base Board® Cavity System is a single skin construction method and is fitted to an existing frame or surface. Expansion and control joints are essential and are recommended at least every 6 metres and between floor levels. Unitex® recommends additional expansion joints to be installed at known wall structural weaknesses, i.e. windows, doors and general wall penetrations.

Note:

Expansion/contraction joints are to be installed in the dry render coat and cut through to approx. 75% depth of the EPS substrate. They must be uniform, even in thickness and depth, and be straight, either in a horizontal or perpendicular plane.

The EPS acts as backer and the mastic sealant, e.g. **Uni-Shape® Sealant**, is applied in the cut joint (approx. 8 mm wide and to a depth of approx. 5 mm).

For a controlled and non-dusty render edge to which the mastic adheres, Unitex® recommends pre-treatment with **Unitex Cembond®** acrylic sealer coat.

For a mastic sealant to be effective, it must be approx. half as deep as it is wide, hence for fit-for-purpose expansion and contraction joints, renders must be 6-11 mm.

Expansion joints are to be completed as above prior to the application of Applied Texture Finishes and paints.

Applied Texture Finishes are not to overcoat or bridge the expansion joint.

The cross linked and dried **Uni-Shape® sealant** can only be overcoated with flexible paint being **Uni-PTC®** (pigmented protective top coat).



Unitex Base Board: Guide for Control / Expansion Joints - Front Elevation (use same principles for other elevations)



NOTES:

1. Use this drawing if no other information available.
2. Expansion/Control Joints are required for every elevation.
3. At all dissimilar substrate material junctions expansion/control joints must be installed eg brick to Uni-Base Board, block to Uni-Base Board.
4. Vertical expansion joints are recommended at least every 6 m minimum (refer Builder).

Unitex Base Board: Expansion/Contraction Joints [vertical] - Plan View

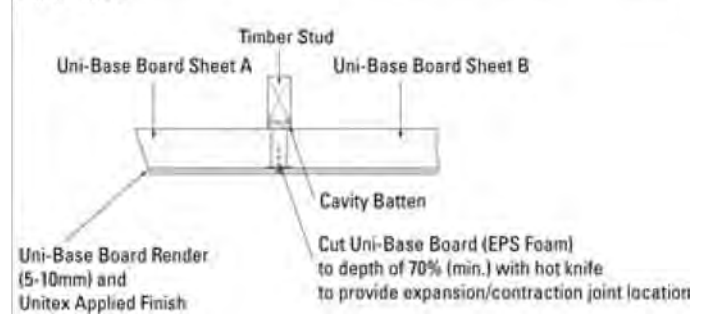

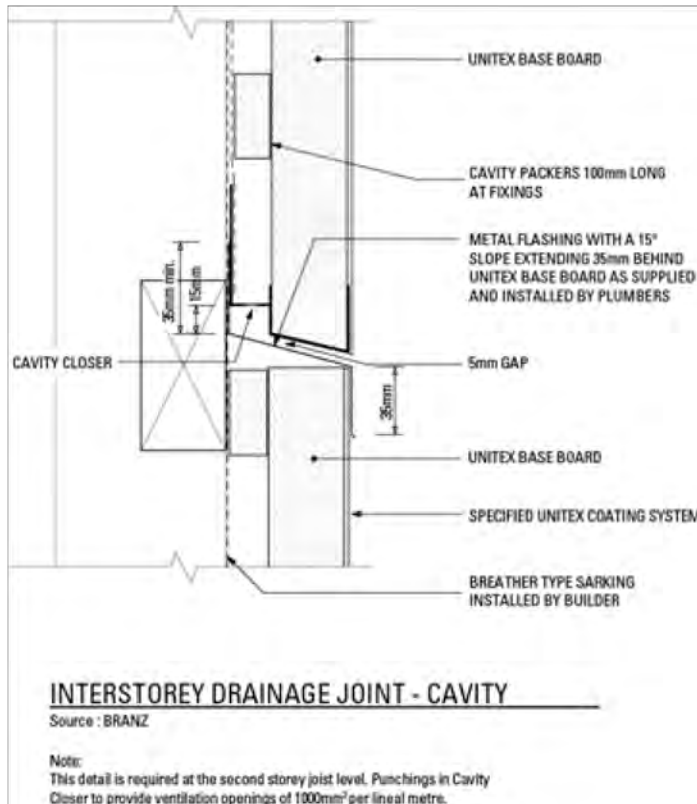

4.2.23 Unitex® Applied Texture Finishes over Uni Base Board®



Purpose: **Applied Texture Finishes** and surface coatings provide colour and surface effect decoration with extra weather and water protection and are to be compatible with and provide excellent adhesion with the rendered substrate. Before applying a **Unitex® Applied Texture Finish**, ensure that the surface is thoroughly dry. (see **4.2.15 Importance of thorough drying**). Various texture effects from a sandy finish to scratch and rough cast are available when using products from the **Uni Trowel Décor®** and **Uni Roll Décor®** ranges and these product ranges can be factory tinted. Alternatively, where cement effects are desirable, **Uni Dry Cote®** textures in powder form, which are prepared in a similar method as **Uni Dry Cote® Base Board Render**, can also be used as a trowel finish that is applied over render.

Uni Dry Cote® textures are largely not available as pre-coloured products and it is recommended that the topcoat, **Uni-PTC®**, which can be tinted, be coated over **Uni Dry Cote®** textures. These coatings enhance the decorative effect, durability, washability, rub resistance and limit the moisture ingress of the **Unitex Base Board® Cavity System**.

N.B. Unitex® continue to offer innovative products to the market and are now offering a limited range of earthy colours in the Uni Dry Cote® texture range. Contact Unitex® for details.

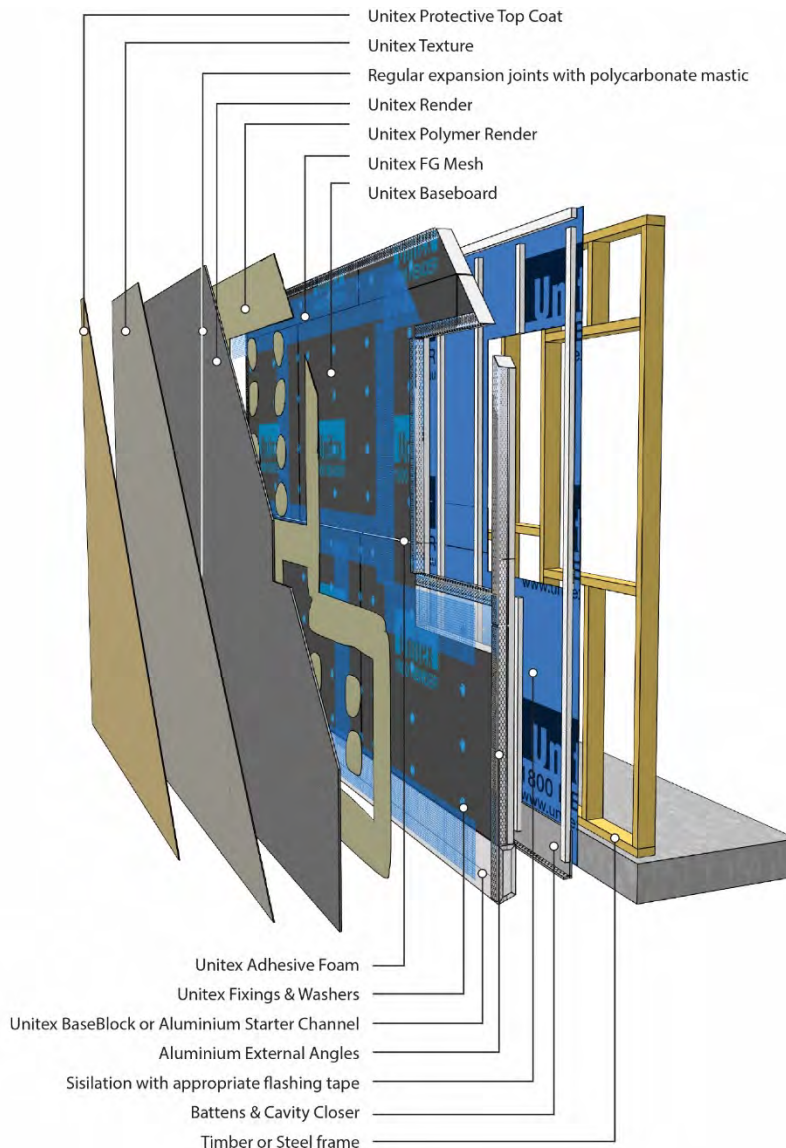

Uni Trowel Décor® and **Uni Roll Décor®** are paste products that are directly applied with a trowel or roller whereas **Uni Dry Cote®** Texture is a powder that must be added to 3.5-4 litres of clean water and mixed with a power drill/mixer until a smooth, lump free consistency of trowelling viscosity is formed. Again, leave the mix to stand for 5 minutes and re-mix with the power drill/mixer and adjust the consistency as appropriate.

A coating of tinted or white **Uni-PTC®** is applied by paint roller, brush or spray equipment after 72 hours if WME is $\leq 12\%$ to provide a long lasting, matt surface.

Clean Up

Clean up with water (away from finished surfaces).

Important Notes

Do not apply Renders or Applied Texture Finishes on unprotected surfaces when rain is anticipated. In damp, cold and/or humid conditions, through drying may take 7 days and longer.

Avoid applications in full sun, on hot surfaces or in hot, windy conditions.

Application of product should be carried out on a day with temperatures above 10°C and below 35°C.

The coated area must be protected from damage until the completion of the project. Finished work must be protected from rain, frost and severe weather conditions until fully dried.

Primer/Sealer/Top Coats should not be applied until the Applied Texture Finish is thoroughly dry (WME ≤12%, see **4.2.15 Importance of thorough drying**).

In keeping with other trade damage and builder issues, it is often best to apply the **Uni-PTC®** top coats as late in the project as possible prior to handover (especially in commercial multiunit projects).

Repairing damaged Base Board System will require removal and replacement from stud to stud and complete re-rendering and meshing from closest corner to closest expansion joint, etc (meaning NOT spot patching) for a generally acceptable result for the builder/home owner. Unitex technical staff may be contacted for recommendations and advice.

Lighter colours reflect heat from the surface better than darker colours and especially from lower roof lines onto upper storeys.

Packaging

Unitex® Polymer Render

Plastic pail

Volume: 15 litres (approx. 23 kg), 32 pails per pallet

Uni Dry Cote® Base Board Render

Paper sack/bag

Volume: 15 litre net per bag, 60 bags per pallet

Uni Décor® Applied Texture Finishes

Plastic pail

Volume: 15 litres (approx. 23 kg), 32 pails per pallet

Uni Dry Cote® Applied Texture Finishes

Paper sack/bag

Weight: 20 kg net per bag, 60 bags per pallet

Uni-PTC® protective top coat

Plastic pail

Volume: 15 litres (approx. 17 kg), 32 pails per pallet

Table 6 Coverage

Product	Coverage m²/pail or bag	Application thickness (mm)
Unitex[®] Polymer Render	4-10	2-5
Uni Dry Cote[®] Base Board Render	1-2	5-10
Uni Décor[®] range	16-18 (fine grades) 9-11 (medium grades) 4-8 (coarse stucco grades)	0.3-0.6 0.8-1.2 2-4
Uni Dry Cote[®] range	8-10	1-1.5
Uni-PTC[®]	30-50 (sealer and 2 coats) Flexible Paint film	



Note: Total coating thickness applied over the EPS must be not less than 10 mm.

Table 7 Technical Data for Unitex® Applied Texture Finishes and Topcoats

Product	Form	Prepare by:	Apply with:	Pot Life
Unitex® Polymer Render	Paste	Add 5-10% cement by power mixer	Hawk & Trowel	With cement added – 2 hours, otherwise – 6 months
Uni Dry Cote® Base Board Render	Powder	Add to 4 litres water with power mixer until smooth paste forms	Hawk & Trowel, Float to finish	As powder in unopened bags – 6 months As paste – 2 hours
Uni Décor® range	Paste	Ready to use	Roller or Trowel, Float to finish	In unopened pails – 1 year
Uni Dry Cote® range	Powder	Add to 4 litres water with power mixer until smooth paste forms	Hawk & Trowel, Float to finish	As powder in unopened bags – 1 year As paste – 2 hours
Uni-PTC®	Viscous Liquid	Ready to use	Roller, brush or spray	In unopened pails – 1 year

4.2.24 Maintenance

Walls clad with the **Unitex Base Board® Cavity System** are recommended to be cleaned annually by low pressure water washing to remove all existing surface contaminants, with special attention to sheltered areas. When re-coating is required at the 7 to 8 year period, to maintain long term integrity and a pristine condition, this can be carried out using **Uni-PTC®** over a cleaned surface. The shade can be changed and we recommend a sealer and 2 coats with a roller for achieving good hiding and more coats if a light colour covers a dark colour.

Annual inspections are to be implemented after completion to clearly identify any faults in the cladding, sealant, flashings and any other connections. Physical damage must be repaired as soon as possible using the appropriate Unitex® system. A repair process must be implemented immediately to address any faults so the long-term warranty is not compromised. Contact sales@unitex.com.au for advice and recommendations.

4.2.25 Unitex Base Board® Cavity System for peace of mind

The **Unitex Base Board® Cavity System** is quick and easy to install but relies on a team effort:

- Quality Substrate (by Builder)
- Quality Product System (by Unitex®)
- Experienced and trained Tradespeople (to finish)

So when the **Unitex Base Board® Cavity System** is installed as above with all the nominated Unitex® products as described in this Manual, Unitex® backs up with a site specific seven year warranty.

Unitex® Granular Marble Pty. Ltd. is a system originator and accepts nil substitution of components, other than those supplied and specified by Unitex® at the time of purchase.

5. Installation and Fixing Details

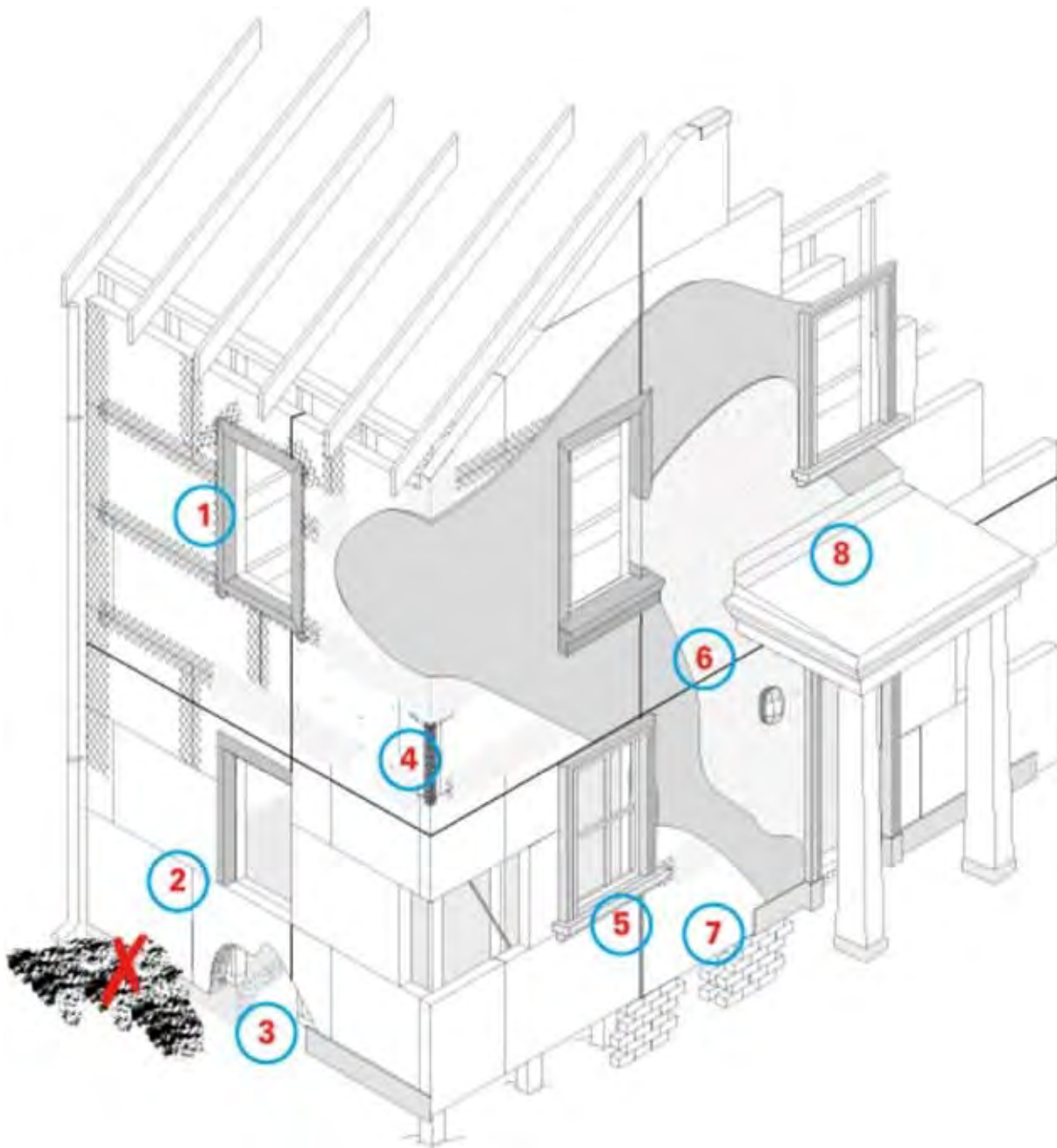

Key to Design Features of a building

1. See 4.2.11 and 4.2.21
2. See 4.2.10
3. See 4.2.5
4. See 4.2.12
5. See 4.2.22
6. See 4.2.22 Inter-storey Drainage and Joint-Cavity
7. See 5.5
8. See 5.1.9

5.1 General Design Requirements

General design requirements that should be incorporated at the design stage of the building:

5.1.1 Windows

Aluminium Window & Door Joinery

All windows, doors, etc., shall be fitted by the appointed joinery installer. They must be installed prior to the Uni-Base Board® sheets and stainless steel angles. The window frames are to be installed offset from the timber frame to allow for the cavity and flashings plus a 3 mm gap between the batten and the back face of the aluminium facing (approximately 24-25 mm from frame to allow for tapes). If a joinery support bracket is used, ensure that it finishes 10 mm short of the joinery jambs.



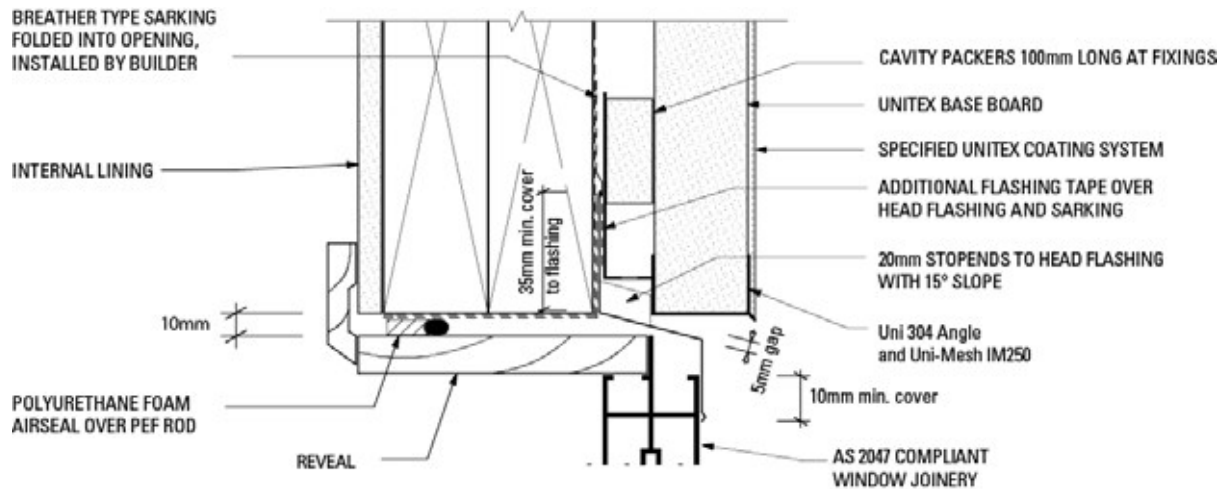

WINDOW HEAD - CAVITY

Source : BRANZ

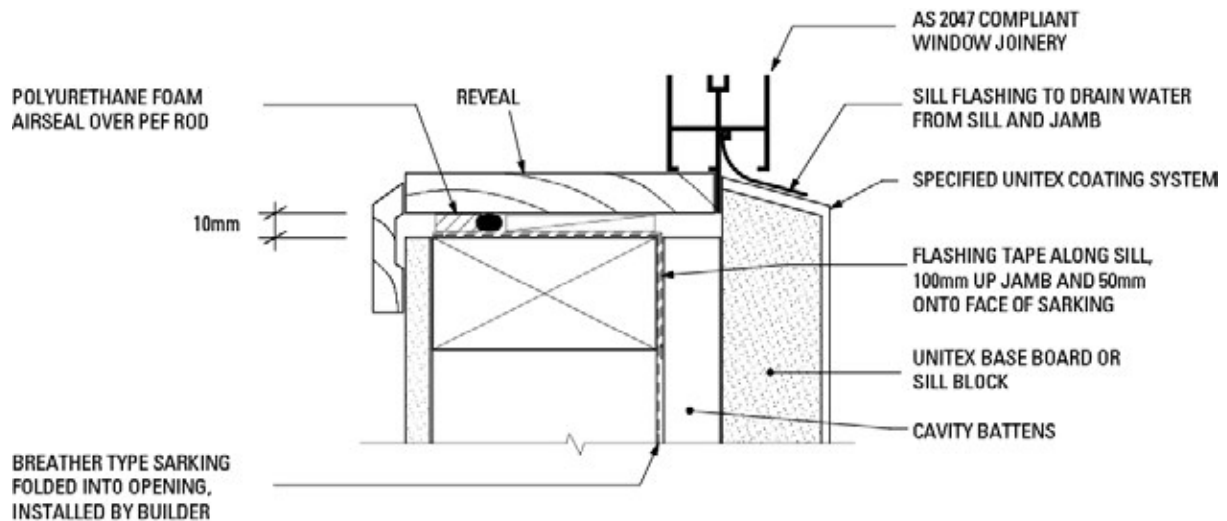

WINDOW SILL - CAVITY

Source : BRANZ

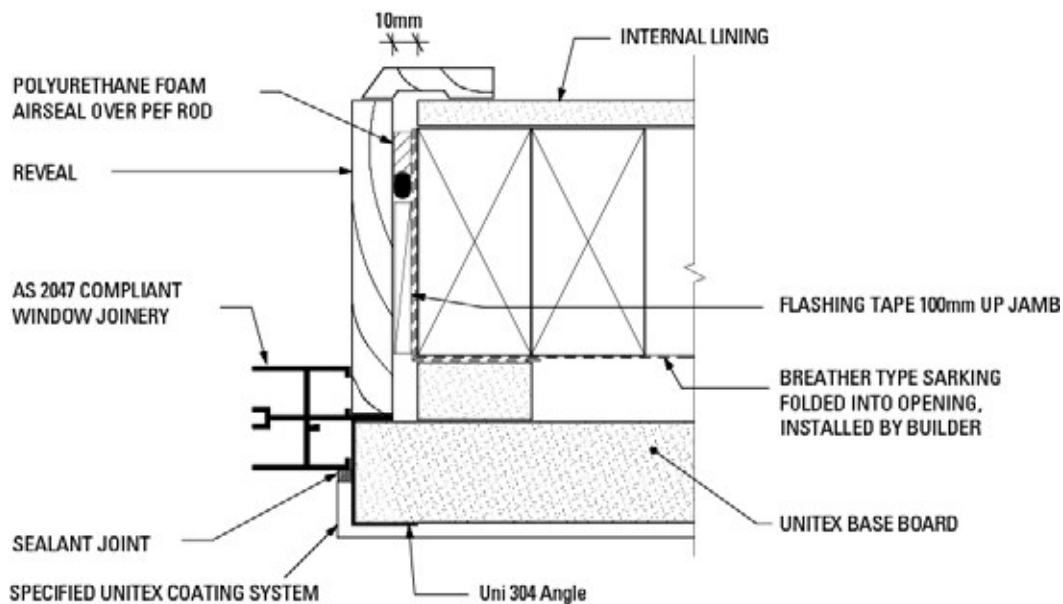

WINDOW JAMB - CAVITY

Source : BRANZ

5.1.2 Rendered Balustrade tops

All rendered horizontal surfaces must have a minimum 8° fall and have **Uni-Flex® Membrane** acting as a water-proofing barrier coating. For added water-proofing on balustrade and parapet tops, **UniFlex® Membrane** can be drill mixed 1:1 with fresh cement and applied with a layer of **Uni-Mesh®** alkali resistant fibreglass mesh embedded into the mix attaining a total minimum film thickness of 11.5 mm. Extend membrane 75 mm up or down adjacent vertical surfaces and 50 mm past any sheet joints and allow to dry overnight. All **Uni Flex® Membrane** waterproofing is to be over coated with **Uni Dry Cote® Base Board Render**.

Uni-Flex® Membrane is a coating with very high acrylic polymer content and a high viscosity that is rolled or brushed as a thicker than normal paint film over render and texture finishes.



5.1.3 Eaves

There is no minimum eaves size specified for this system. Normal building practices should be observed and Unitex® prefers eaves of minimum 450 mm. However, if eaves are minimal, a metal flashing, installed by a plumber, is required with downturned nib of minimum 50 mm and extends a minimum 10 mm past the rendered surface as wind driven rain is not to penetrate in behind the system.

5.1.4 Soffits

Soffits shall be fixed before cladding is installed. A 6/8 mm bead of **Uni-Shape® Sealant** is installed after EPS cladding is completed and before plastering commences to allow a flexible separation between the soffit and the rendered surface.

Unitex Base Board: at Soffit

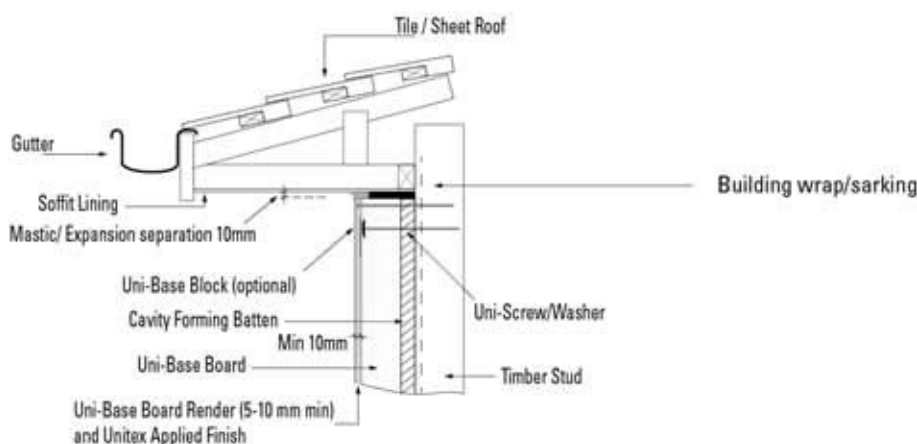

Unitex Base Board Cavity System: Parapet / Soffit Drip Detail

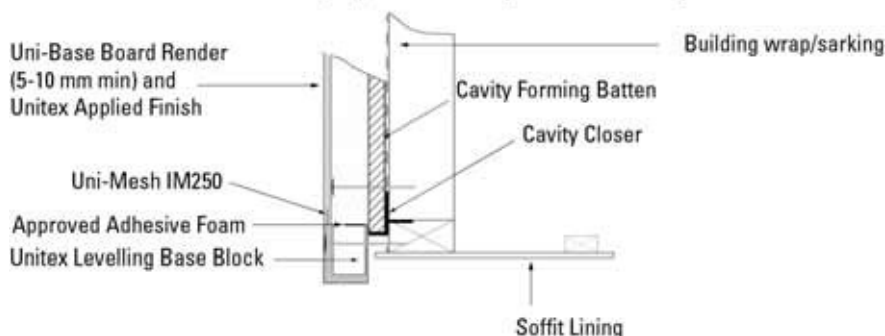

NOTE:
Bottom edge of Uni-Base Board should never be left exposed to the weather.

5.1.5 Architectural Shapes & Profiles



Any architectural shapes and profiles used to create detailing shall be correctly cut to size and installed according to the Unitex® Installation Guide (see www.unitex.com.au) for the appropriate type of shapes and profiles. For example, **Tex Moulds** from Unitex® made from EPS are fixed with Approved Adhesive onto **Uni-Base Board**® sheets whereas lightweight concrete mouldings (**Uni-Shape**® by Unitex®) require mechanical fixers. **Uni-Shape**® Sealant mastic and adhesive foam must be used to fill gaps between profiles and **Uni-Base Board**® sheets.

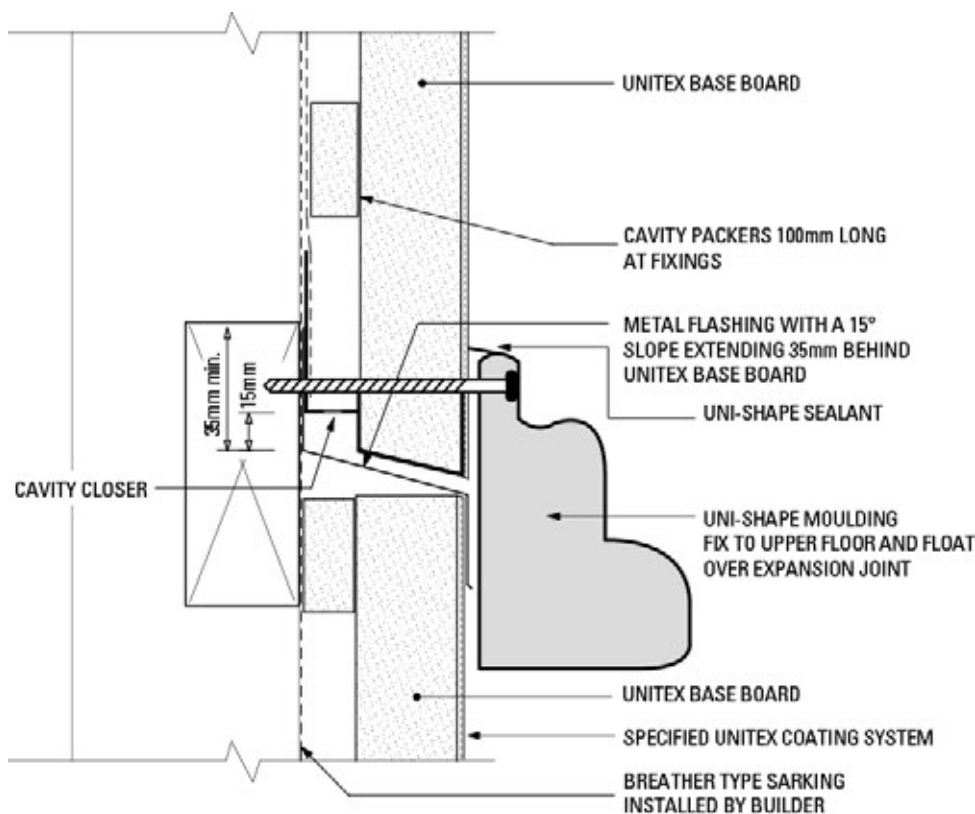

FITTING OF UNI-SHAPE MOULDING OVER INTERSTOREY DRAINAGE JOINT - CAVITY

Source : BRANZ

Note:
This detail is required at the second storey joist level. Punchings in Cavity Closer to provide ventilation openings of 1000mm² per lineal metre.

5.1.6 Penetrations and Fittings

Penetrations and fittings such as waste pipes and fixing brackets shall be flashed with a square sized flexible flashing tape fixed 100 mm all round onto the building wrap and a 25 mm strip wrapped around pipes or fitted to secure the star cut in the square, prior to cladding installation. All fittings are to be mastic sealed at the surface. Note: all penetrations through the **Unitex Base Board® Cavity System** shall be adequately supported at the framing by blocking sized to suit.

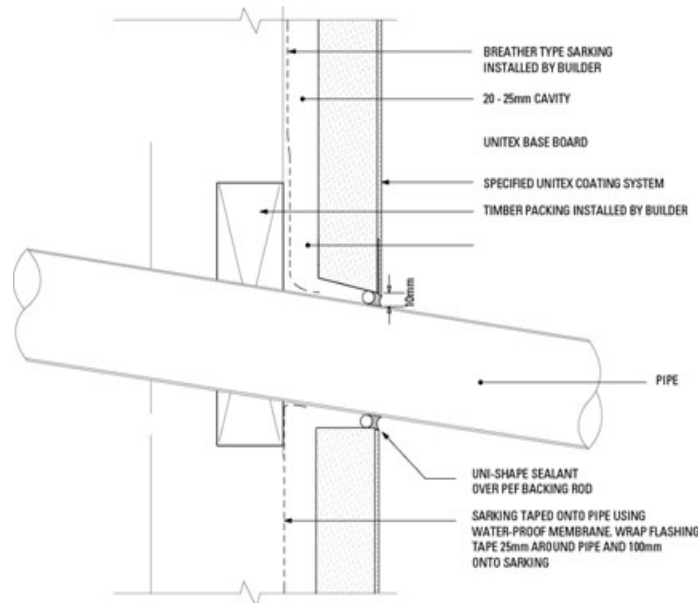

PIPE PENETRATION - CAVITY

Source : BRANZ

Note:
Where possible pipe penetrations should be installed sloping down.

Unitex Base Board Cavity System: Fixing of heavy objects e.g. drainage pipe [Back blocking]

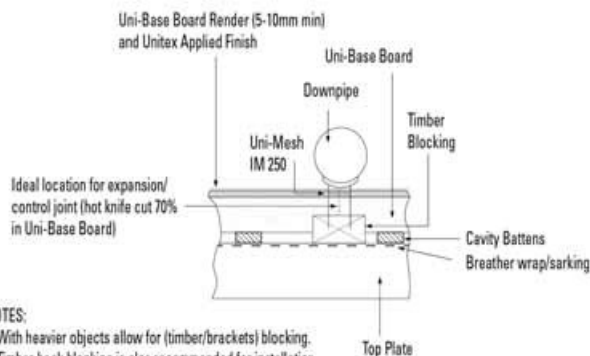

- NOTES:
1. With heavier objects allow for (timber/brackets) blocking.
 2. Timber back blocking is also recommended for installation of larger Uni-Shape Mouldings.
 3. Generally two sheets of Uni-Base Board would be joined at this weakened position and strengthened with Uni-Mesh IM 250.
 4. Or an ideal positioning for expansion/control joint.

Unitex Base Board Cavity System: Fixing of lightweight objects e.g. external light to Uni-Base Board

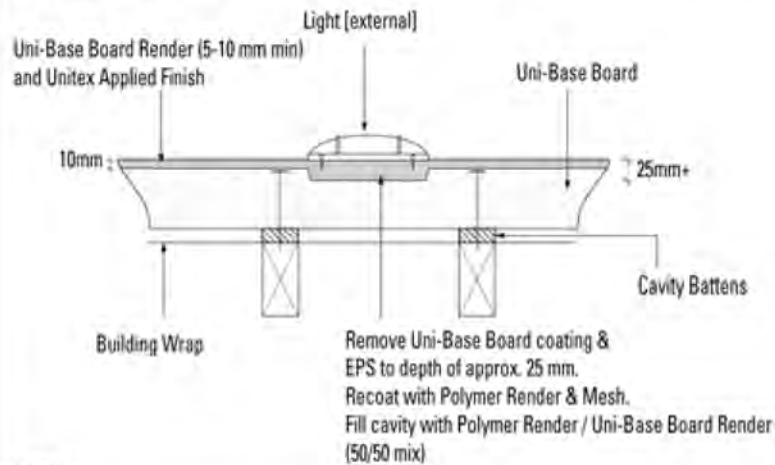

NOTES:

1. For lighter objects fixed to wall allow for Render/Fill layer coat to be approximately 25mm depth (cut to depth).
Remove Uni-Base Board material to depth of \approx 25mm. Fill cavity with Polymer Render/Uni-Base Board Render \approx 25-30mm depth.
2. For awnings fix brackets to timber studs/noggings prior to Uni-Base Board installation.

All electrical wiring shall only penetrate the **Unitex Base Board® Cavity System** in the appropriately sized uPVC conduit with flange installed, at a minimum downwards rake of 5°. All plumbing piping, etc, installed should have a downwards rake from the inside.



5.1.7 Flashings

Sealants cannot be fully relied on for detailing around parapets, box gutters, windows etc. with good design being the only real solution. All terminations and junctions must be adequately flashed using materials which are compatible with the Unitex® Base Board Cavity System and comply with AS/NZS 2904 -1995. Parapets must be metal flashed and box gutters are to be back flashed. Parapet flashing is best designed with an approx. 10° fall back to flow water into a box gutter. The flashing must cover the complete top surface of the EIFS system and protrude at least 10 mm past the render/texture surface and thence turn down and right angle return well down pressing against the finished wall surface to create a drip line away from the wall. The minimum return dimension should be 50 mm (excluding drip edge) for wind zones N1 and N2, and 70 mm (excluding drip edge) for N3 to prevent water flow back. This work should be carried out by plumbers.

5.1.8 Parapets

Exposed Parapets by their unsupported height need to be well braced and may require extra studs and noggins for strengthening to reduce movement with wind load. The Unitex® recommended solution for parapets is to use a purpose made metal flashing on the top of the wall. For more details, see 5.1.7 Flashings.



Individual engineered solutions i.e. **Uni-Shape®** capping moulds, may be installed over the metal flashing as long as the flashing is not compromised. To avoid possible cracking caused by wind load stresses, expansion joints are recommended to be installed at the base of the parapet frame to lower wall frame junction.

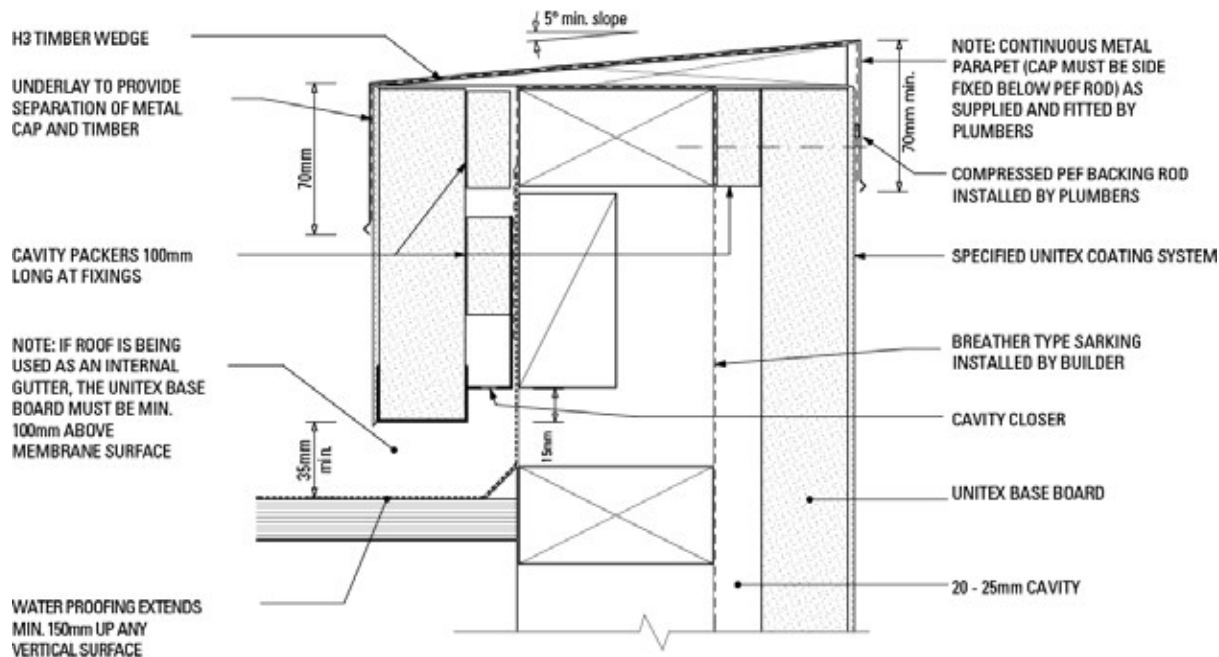

PARAPET METAL CAPPING - CAVITY

Source : BRANZ

Note:
Punchings in Cavity Closer to provide ventilation openings of 1000mm² per lineal metre.

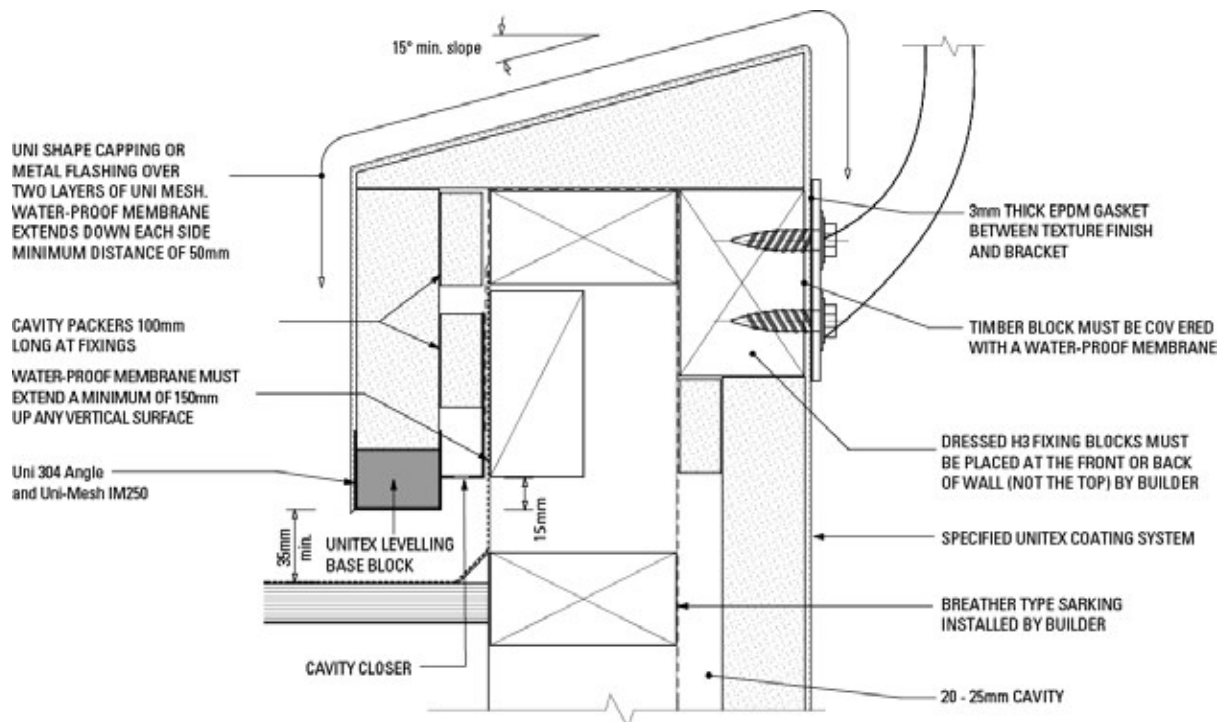

BALCONY CAPPING - CAVITY

Source : BRANZ

Note:
Punchings in Cavity Closer to provide ventilation openings of 1000mm² per lineal metre.

Unitex Base Board Balcony Upstand Wall: (Options)

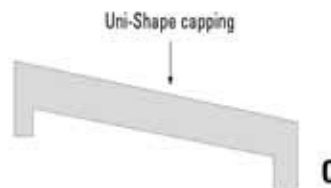
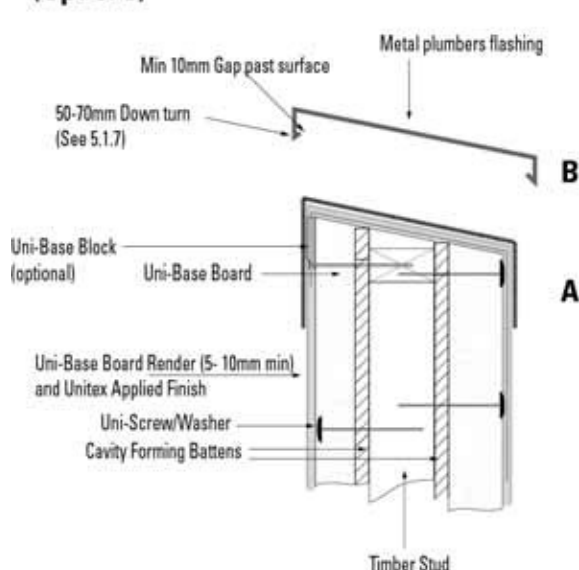

NOTE 1:
The flashing angle and relevant details as determined by Engineer's specifications.

- Option A - Flexible re-inforced waterproof render
- Option B - Metal plumbers/decorative flashing
- Option C - Overlaying either A or B with Uni-Shape capping moulding in profile of your choice

NOTE 2:
Balcony handrails to be fixed to engineered sub-frame from the front or rear elevation (NOT THROUGH UPPER SURFACE)

Unitex Base Board: Parapet Facade (recommended)

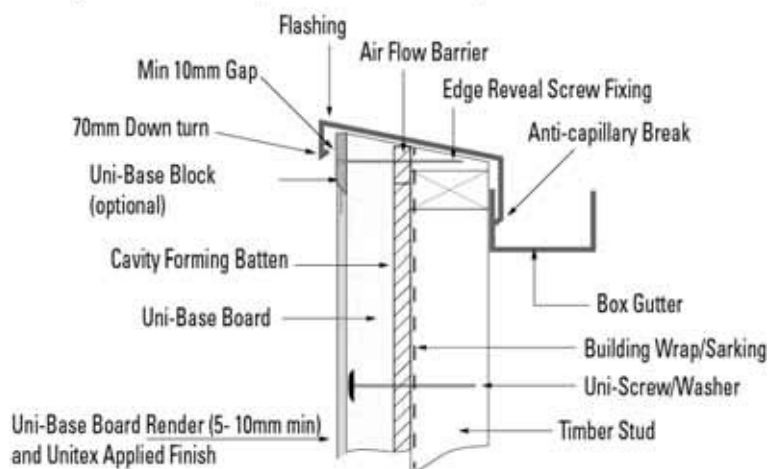

NOTE:
The flashing angle and relevant details as determined by Engineer's specifications.

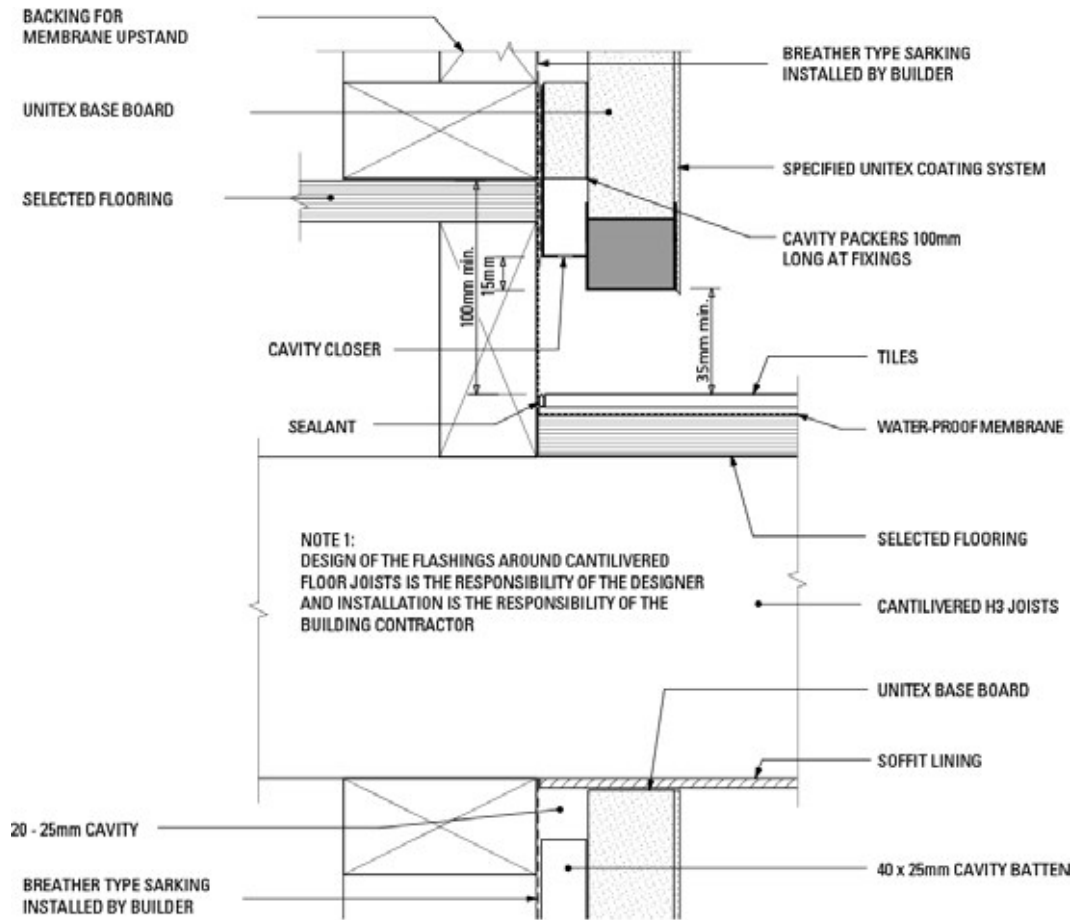

ENCLOSED BALCONY - CAVITY

Source : BRANZ

Note:
Punchings in Cavity Closer to provide ventilation openings of 1000mm² per lineal metre.
Termite barriers to be installed as required by the BCA, seek professional advice.

5.1.10 Pergola/Timber Beam/Deck Detail

Unitex Base Board Cavity System: Pergola / Timber Beam / Deck Detail

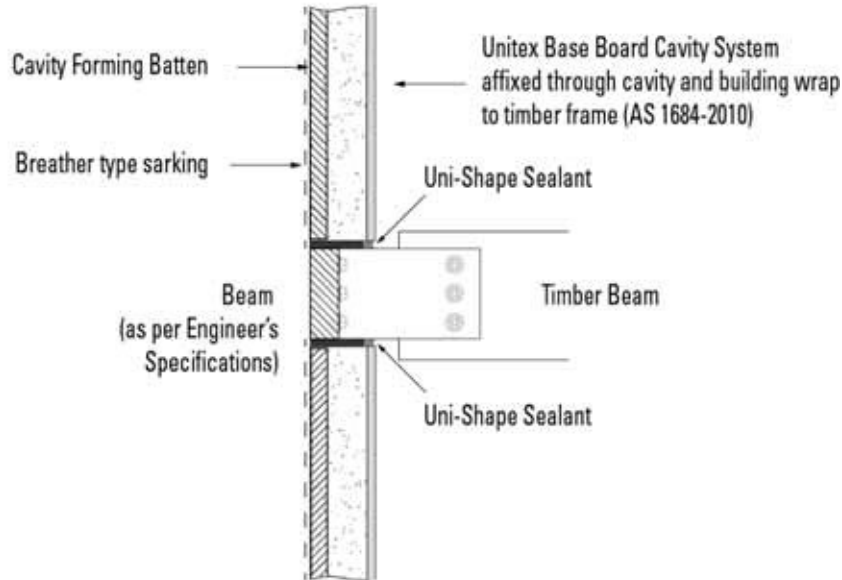

NOTES:

1. It is recommended that a horizontal expansion joint be placed between each level.
2. The ultimate responsibility for determining the location of expansion joints is with the Designer / Engineer / Builder.

5.2 Condensation & Moisture

Closed panel systems such as the **Unitex Base Board® Cavity System** allow low levels of water vapour transmission. The primary advantage of the **Unitex Base Board® Cavity System** is the resistance to water penetration in the first instance. This EIFS system does not negate the need for breathable sarking wrap, which acts as a last line of defence for moisture ingress. Sarking is supplied as part of the builder's works and should be as specified by the building designer. Unitex recommends sarking be either kraft-based paper complying with AS/NZS 4200.1 - 2007, or breather-type membranes covered by a valid BRANZ Appraisal for use as wall wraps.

5.3 Other Fixtures

Light weight fixtures can be attached to the finished wall using toggle bolts however it is essential that additional wall framing be installed to support heavier attachments such as awnings.

5.4 Balustrades

Exposed balustrades, by their unsupported height, need to be well braced and require extra studs and noggins for strengthening to reduce movement with wind and other physical loads. These details must be worked out by the building designer. Unitex® stresses that the top of the balustrade must not be penetrated, must be fully sealed/flushed and inclined to prevent water pooling. Hand rails, etc. are to be fixed to the sub-frame into the side or rear face. Uni-Shape® capping mouldings can be installed over the waterproof flashing for enhanced decorative effects. As balustrades generally suffer some deflection, they must be isolated with expansion/contraction joints from the slab and at junctions, etc.

5.5 Dissimilar Materials



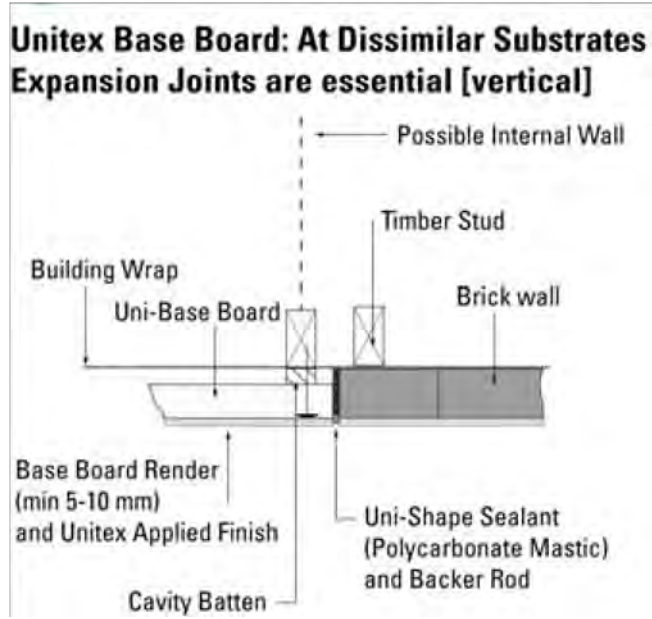

6. Technical Appraisal

The Unitex Base Board® Cavity System has been appraised by BRANZ [Appraisal No. 758 (2018)].

A copy of the Appraisal is available for download from the BRANZ website www.branz.co.nz and the Australian Institute of Building Surveyors website http://aibs.worldsecuresystems.com/partners/branz_appraisals.

Additional supporting information on the material and physical properties of the Unitex Base Board® Cavity System is available by contacting Unitex Granular Marble Pty. Ltd.



7. Safety and Handling

7.1 Handling of Uni-Base Board®

Uni-Base Board® sheets have the great advantage of being relatively light and in most situations are able to be handled by one person. There are however some cautions that are similar to those when handling roof sheets. Being a large flat panel, under windy conditions the panel can be caught by the wind whilst being carried and be pulled out of the person's hands potentially causing imbalance and falling. The falling panel could cause serious damage to people below. It is strongly recommended that Uni-Base Board® sheets not be fitted under windy conditions where there is potential for this hazard. As with all construction, a risk assessment should be carried out with site personnel prior to installation and included in the contractor's site JSA.

For storage and transport purposes, the panels should be stacked flat and in the case of transport, suitably restrained to stop wind getting under the sheets causing them to fly off the pack. Crushing of the edge of the sheet with ropes can be avoided by the use of heavy folded cardboard made into an angle.

Whilst Uni-Base Board® is coated with a weather-resistant render, the wall should be rendered as soon as possible after installation. Prolonged exposure of uncoated polystyrene foam at corners or on cuts can alter the physical appearance in that expanded foam cells can degrade to yellowish powder which must be wire-brushed away.

7.2 Transport & Storage

Powder products must be kept dry, elevated off the floor and preferably on pallets. Pastes must be stored at between 10°C and 35°C in unopened pails.

Table 8 Safety and Handling of Unitex® Renders and Applied Texture Finishes

Product	Hazardous?	Dangerous Goods?	Conditions to avoid	Recommended PPE
Unitex® Polymer Render	No but with cement added, Yes	No	Dust when adding cement, Ingestion, Spills into eyes	Dust masks, eye protection, gloves, dust coats
Uni Dry Cote® Base Board Render	Yes	No	Dust, Ingestion, Spills into eyes	Dust masks, eye protection, gloves, dust coats
Uni Décor® range	No	No	Ingestion, Spills into eyes, Avoid product drying on the skin	eye protection, gloves, dust coats
Uni Dry Cote® range	Yes	No	Dust, Ingestion, Spills into eyes	Dust masks, eye protection, gloves, dust coats
Uni-PTC®	No	No	Ingestion, Spills into eyes, Avoid product drying on the skin	eye protection, gloves, dust coats

Please refer to Material Safety Data Sheets available on www.unitex.com.au

7.3 First Aid Measures

Dust

Avoid inhalation of any dusts encountered when using these products. Wear a suitable respiratory protection mask, avoid prolonged skin contact with wet mortars and wear goggles to limit eye contact.

Wear protective clothing to minimise skin contact.

Ingestion

If swallowed, wash out mouth with water. Do NOT induce vomiting. Drink at least two glasses of water. Seek medical attention.

Eyes

Wash with copious amounts of water for 15 minutes holding eyelids open. Take care not to rinse contaminated water into the non-affected eye. Seek medical attention.

Advice to Doctor

Treat symptomatically.

7.4 Health and Safety

Think Safe, Act Safe

To assist in maintaining a safe and healthy workplace, take note of the following:

Ensure the workplace is safe. This includes attention to plant and equipment.

Insist that safe work methods are practiced.

Provide supervision and training where appropriate.

Ensure that everyone on site understands and accepts their responsibilities to promote a workplace that is safe.

Ensure that all health and safety requirements are adhered to.

Consult your authorised Workplace Health and Safety Officer for specific advice.



8. Warranty

Unitex Base Board® Cavity System for peace of mind

Unitex Base Board® Cavity System is quick and easy to install but relies on a team effort:

- Quality Substrate (by Builder)
- Quality System (by Unitex)
- Experienced and trained Tradespeople (to finish)

So when **the Unitex Base Board® Cavity System** is installed as above with all the nominated Unitex products as described in this Manual, Unitex® backs up with a seven year warranty.

Unitex® provides a seven year warranty for defective product only (product replacement only) against the **Unitex Base Board® Cavity** complete system, providing the components are of the quality specified and are applied strictly according to the guidelines laid down in this Manual. This Manual must be read and understood before installing the **Unitex Base Board® Cavity System**. Unitex® cannot be held responsible, and hence no warranty applies, if **Unitex Base Board® Cavity System** and its components are not supplied and installed according to the guidelines.

The selection of an Applicator to install the **Unitex Base Board® Cavity System**, is the client's responsibility. Unitex® can recommend and arrange a quotation from endorsed applicators. Unitex® strongly recommends previous workmanship be inspected before contracting an applicator. A minimum of three recently jobs should be checked first-hand by the client. As advised above, insufficient or inadequate construction of expansion/contraction joints could lead to cracking of the **Unitex Base Board® Cavity System**. We reaffirm that, whilst we provide recommendations as to their locations and treatment in **Unitex Base Board® Cavity System**, this is not covered by the warranty. The placing of control joints is ultimately the responsibility of the Builder/Engineer/Specifier and not Unitex®.

Warranty is null and void if product is not installed in accordance with the guidelines set out in this Specification or if any non-approved Unitex® product is used. All Warranties are site specific and are based on documented complete system delivery to site.

Disclaimer

The information and recommendations contained herein are based on tests and data believed to be reliable and are issued for your guidance. However, we cannot accept any responsibility for the results as the use and application of the products is beyond our control.

Confidence and trust

For your peace of mind the Uni-EIFS systems by Unitex have been supplied and installed in Australia since 1983 with excellent results. The Unitex team are proud of having over 20 years of experience and knowledge in EIFS projects without any guarantee claims.

Both Uni-Base Board and Uni-TWS are finished with our proven range of weatherproof protective coating systems. Over 5 million square metres of external wall in Australian homes and commercial projects have been protected from our harsh, seasonal weather conditions by Unitex.



Our experienced Unitex technical representatives are on call to visit your site and advise on correct installation, texture and colour. And the all important technical site related issues.

Free Plan Collection and Quotation Service

Freecall 1800 647 374 and a Unitex technical representative will supply a quote. Unitex can quote supply only or arrange for a supply and install quote from an approved applicator.

Specifier’s Clause:

The external facade (insulating lightweight cladding) shall be the Uni-Base Board™ System (Low Build) as detailed in the Uni-Base Board™ Manual (dated August 2018). It shall have the following characteristics:

1. Soft-body Impact Strength minimum of 20 joules.
2. Minimum coating thickness of the Uni-Base Board system is to be no less than 5 mm covering the washers.
3. Edge and Sill Reveals protected with Uni-Mesh IM250 and Uni-304 Angle.
4. A ‘complete wall’ R-value tested result of minimum 2.0 (based on 75 mm thick EPS foam fitted over typical stud framing).
5. Expansion Joints to be specified to allow for normal substrate movement.

It shall be supplied by Unitex Granular Marble Pty Ltd and shall be installed as per the Uni-Base Board™ Manual by skilled tradespeople. Contact details: E-mail sales@unitex.com.au / Telephone +61 3 9768 4900.

The information contained in this document is based on data available at the time of writing, which we believe is accurate and reliable. Unitex reserves the right to change the information without prior notice.



Unitex
 22 Park Drive
 Dandenong VIC 3175
 Phone: (03) 9768 4900
 Fax (03) 9768 4999
www.unitex.com.au

Unitex (NSW)
 14 Artisan Road
 Seven Hills NSW 2147
 Phone: (02) 9838 0911
 Fax (02) 9838 9555
www.unitex.com.au

URW (Oakleigh)
 1346 North Road
 Oakleigh VIC 3167
 Phone: 1800 RENDER
 Fax (03) 9544 3620
www.render.com.au

URW (SA)
 2/54-56 Cavan Road
 Dry Creek SA 5094
 Phone: (08) 8262 7900
 Fax (08) 8262 7922
www.render.com.au