

# **STUDY REPORT**

**SR 305 (2013)**

## **Bracing ratings for non-proprietary bracing walls**

**SJ Thurston**



The work reported here was funded by BRANZ  
from the Building Research Levy.

© BRANZ 2013  
ISSN: 1179-6197

## **Preface**

This is the first BRANZ report which attempts to determine the bracing ratings of non-proprietary bracing walls.

## **Acknowledgments**

This work was funded by the Building Research Levy.

## **Note**

This report is intended for engineers, designers and others who wish to determine the bracing ratings of existing walls in older construction and also those who wish to use the bracing ratings of non-proprietary bracing walls in new construction.

# **Bracing ratings for non-proprietary bracing walls**

## **BRANZ Study Report SR 305**

**SJ Thurston**

### **Reference**

Thurston SJ 2013. Bracing ratings for non-proprietary bracing walls. BRANZ Study Report No. 305. Judgeford, Wellington.

### **Abstract**

In New Zealand the wall bracing ratings used for new houses are generally provided by manufacturers based on tests on their proprietary systems to the BRANZ P21 test method. Designers then ensure at each level and in each direction, the demand wind or earthquake loads are less than the sum of the resistances of the bracing elements. However, when renovating or repairing older buildings the bracing strength of existing construction is often not known and thus cannot be used in the bracing calculations usually required by the building consent authority. This report is intended to provide the bracing ratings of many common bracing walls in older construction to fill this need. Some of the systems tested may be deployed in new construction and the bracing ratings published herein may therefore be used.

<b>Contents</b>	<b>Page</b>
<b>1. INTRODUCTION.....</b>	<b>1</b>
<b>2. LITERATURE SURVEY.....</b>	<b>1</b>
<b>2.1 Lath and plaster walls.....</b>	<b>1</b>
2.1.1 Wikipedia description.....	1
2.1.2 NZSEE recommendations.....	1
2.1.3 Porter and Coheen's recommendations.....	2
2.1.4 Anderson's tests.....	2
2.1.5 Shelton's insitu tests.....	4
2.1.6 Beattie's tests.....	5
2.1.7 Literature survey.....	6
<b>2.2 Fibrous plaster walls.....</b>	<b>8</b>
2.2.1 Literature survey.....	8
<b>2.3 Diagonal braces.....</b>	<b>10</b>
2.3.1 Literature survey.....	10
<b>2.4 Plasterboard bracing systems.....</b>	<b>11</b>
2.4.1 NZS 3604.....	11
<b>2.5 Timber shear walls.....</b>	<b>11</b>
2.5.1 NZSEE recommendations and comments.....	11
2.5.2 Cooney.....	12
<b>3. BRANZ TESTS.....</b>	<b>12</b>
<b>3.1 Systems tested.....</b>	<b>12</b>
<b>3.2 Lath and plaster (Lath 1).....</b>	<b>14</b>
<b>3.3 Brace 1: 150 x 25 let in brace at 45° (Brace 1).....</b>	<b>16</b>
<b>3.4 90 x 45 single brace cut between studs (Brace 2).....</b>	<b>20</b>
<b>3.5 90 x 45 double brace cut between studs (Brace 3).....</b>	<b>24</b>
<b>3.6 Dogleg brace (Brace 4).....</b>	<b>27</b>
<b>3.7 200 x 10 horizontal board (Board 1).....</b>	<b>30</b>
<b>3.8 140 x 20 bevel-back weather board (Board 2).....</b>	<b>32</b>
<b>3.9 Standard plaster board nominally fixed on one side only (Sheet 1).....</b>	<b>34</b>
<b>3.10 Standard plaster board nominally fixed on both sides (Sheet 2).....</b>	<b>35</b>
<b>3.11 Tempered hardboard nominally fixed on one side only (Sheet 3).....</b>	<b>36</b>
3.11.1 Panel pin fixings only.....	36
3.11.2 30 x 2.5 nails with no additional uplift restraints.....	37
3.11.3 30 x 2.5 nails with additional uplift restraints.....	37
<b>3.12 Horizontal corrugated steel (Sheet 4).....</b>	<b>40</b>
<b>3.13 Vertical corrugated steel (Sheet 5).....</b>	<b>45</b>
<b>3.14 Combo1 – a combination of Sheet 1 and Brace 3.....</b>	<b>49</b>
<b>4. REFERENCES.....</b>	<b>54</b>
<b>APPENDIX A APPLICATION OF THIS RESEARCH.....</b>	<b>55</b>

## Figures

## Page

Figure 1. Anderson (1981) test rig .....	3
Figure 2. Anderson (1981) Specimen C – gypsum lath and plaster .....	3
Figure 3. Anderson Specimen D – timber lath and plaster.....	4
Figure 4. Beattie (2006) racking hysteresis loops for the 2.4 m wide lath and plaster wall .....	6
Figure 5. View of an earthquake-damaged lath and plaster exterior wall (Buchanan et al 2011) .....	7
Figure 6. View of an earthquake-damaged interior lath and plaster wall (Buchanan et al 2011) .....	7
Figure 7. Wall 1 framing in the insitu fibrous plaster wall tests .....	9
Figure 8. Fibrous plaster Wall 1 hysteresis loops.....	10
Figure 9. Fibrous plaster Wall 2 hysteresis loops.....	10
Figure 10. Applying plaster to the lath and plaster test wall .....	15
Figure 11. Plaster squeezed between laths .....	15
Figure 12. Racking hysteresis loops for the 2.4 m wide lath and plaster wall made for this test report.....	16
Figure 13. Specimen for 150 x 25 let in brace at 45° .....	17
Figure 14. Joint at top plates in specimen for 150 x 25 let in brace at 45° .....	17
Figure 15. Joint at intermediate studs in specimen for 150 x 25 let in brace at 45° .....	18
Figure 16. Diagonal brace lifts top plate in tests before connection strengthening .....	18
Figure 17. Hysteresis loops for 150 x 25 let in brace at 45° before connection strengthening .....	18
Figure 18. Diagonal brace lifts top plate in tests after connection strengthening.....	19
Figure 19. Nails pull out of diagonal brace connection.....	19
Figure 20. Hysteresis loops after connection strengthening.....	20
Figure 21. Specimen for single brace at 45° cut between studs.....	21
Figure 22. Centre joint in specimen for single diagonal braces cut between studs.....	21
Figure 23. Bottom joint in specimen for single brace at 45° cut between studs.....	21
Figure 24. Nailing on the diagonal braces in specimen for single brace at 45° cut between studs .....	22
Figure 25. Hysteresis loops for specimen with single brace at 45° cut between studs .....	22
Figure 26. Brace in tension.....	23
Figure 27. Brace in compression .....	23
Figure 28. Specimen for double diagonal braces cut between studs .....	24
Figure 29. Centre joint in specimen for double diagonal braces cut between studs .....	24
Figure 30. Nailing at the junction of the diagonal braces in specimen for double diagonal braces cut between studs .....	25
Figure 31. Hysteresis loops for Brace 3 before strengthening.....	25
Figure 32. Strap added to Brace 3 after top plate lifted.....	25
Figure 33. Hysteresis loops for Brace 3 after strengthening .....	26
Figure 34. Gaps opened at joints in tension in Brace 3 after strengthening .....	26
Figure 35. Little joint movement occurred at the intersection of diagonal braces (photograph taken at same stage as Figure 34) .....	27
Figure 36. Dogleg-braced specimen.....	28
Figure 37. Top plate lifting in Brace 4 before strengthening .....	28
Figure 38. Strengthening used in Brace 4.....	29
Figure 39. Gaps opened at joints in Brace 3 during testing after strengthening .....	29
Figure 40. Hysteresis loops for Brace 4 before strengthening.....	29
Figure 41. Hysteresis loops for Brace 4 after strengthening .....	30
Figure 42. Specimen for horizontal boarded wall .....	31
Figure 43. Nailing at stud for horizontal boarded wall .....	31
Figure 44. Hysteresis loops for horizontal boarded wall.....	32
Figure 45. Specimen for weatherboard wall Board 2 .....	33
Figure 46. Nailing weatherboard to stud .....	33

Figure 47. Hysteresis loops for weatherboard wall Board 2 .....	34
Figure 48. Sheet 1 standard Gib® single-lined specimen .....	35
Figure 49. Hysteresis loops for Sheet 1 – standard plasterboard one side .....	35
Figure 50. Sheet 2 standard Gib®-lined on both sides specimen .....	36
Figure 51. Hysteresis loops for Sheet 2 – standard plasterboard both sides.....	36
Figure 52. Sheet 3 hardboard single-lined specimen fixed with panel pins .....	38
Figure 53. Hysteresis loops for Sheet 3 – tempered hardboard one side fixed with panel pins .....	38
Figure 54. Sheet 3 hardboard single-lined specimen fixed with clouts .....	39
Figure 55. Hysteresis loops for Sheet 3 – tempered hardboard one side fixed with clouts and no extra hold-downs .....	39
Figure 56. Sheet3 bottom plate lifting in hardboard-lined specimen fixed with clouts.....	40
Figure 57. Hysteresis loops for Sheet 3 – tempered hardboard one side fixed with clouts with extra hold-downs .....	40
Figure 58. Front view of Sheet 4 – horizontal corrugated iron.....	41
Figure 59. Back view of Sheet 4 – horizontal corrugated iron .....	42
Figure 60. Views of pattern of lead-head nails – horizontal corrugated iron .....	43
Figure 61. Lead-head nails used for Sheet 4 and Sheet 5.....	44
Figure 62. Views of sheet slotting at lead-head nails – horizontal corrugated iron .....	44
Figure 63. Hysteresis loops for Sheet 4 – horizontal corrugated iron .....	45
Figure 64. Front view of Sheet 5 – vertical corrugated iron.....	46
Figure 65. Back view of Sheet 5 – vertical corrugated iron .....	46
Figure 66. Views of pattern of lead-head nails – horizontal corrugated iron .....	47
Figure 67. Views of sheet slotting at lead-head nails – horizontal corrugated iron .....	48
Figure 68. Hysteresis loops for Sheet 5 – vertical corrugated iron .....	49
Figure 69. Combo1 – a combination of Sheet 1 and Brace 3.....	50
Figure 70. Double diagonal brace in Combo 1.....	51
Figure 71. Top plate lifting in Combo 1 .....	51
Figure 72. Diagonal braces separate in Combo 1 .....	52
Figure 73. Centre joint in diagonal brace separates in Combo 1.....	52
Figure 74. Middle studs lift in Combo 1.....	52
Figure 75. Hysteresis loops for Combo 1 – a combination of Sheet 1 and Brace 3.....	53
Figure 76. Component hysteresis loops for Combo 1 – a combination of Sheet 1 and Brace 3.....	53
Figure 77. Calculation to ensure wall panel does not rock nor stud separate from bottom plate .....	58

## Tables

## Page

Table 1. Shear wall strengths .....	4
Table 2. Bracing ratings which can be used with fibrous plaster walls .....	11
Table 3. Summary of details of bracing systems tested .....	13
Table 4. Peak loads resisted by the Brace 1 system .....	20
Table 5. Peak loads resisted by the Brace 3 system. ....	26
Table 6. Peak loads resisted by the Brace 4 system .....	30
Table 7. Peak loads resisted by the component Combo 1 systems .....	50
Table 8. Summary of proposed bracing ratings .....	55

# **1. INTRODUCTION**

When renovating or repairing New Zealand buildings the bracing strength of existing construction is often not known and thus cannot be used in the bracing calculations usually required by the building consent authority. This report is intended to provide the bracing ratings of many common bracing walls in older construction to fill this need. Some of the systems tested may be deployed in new construction and the bracing ratings published herein may therefore be used.

## **2. LITERATURE SURVEY**

### **2.1 Lath and plaster walls**

#### **2.1.1 Wikipedia description**

Lath and plaster is a building process used mainly for interior walls until the late 1950s. After the 1950s, drywall began to replace the lath and plaster process.

The process begins with wood laths. These are narrow strips of wood nailed horizontally across the wall studs. Each wall frame is covered in lath, tacked at the studs. The lath is typically about 50 mm wide by 1200 mm long by 6 mm thick. The gap between the laths is approximately 10 mm.

Temporary lath guides are placed vertically to the wall, usually at the studs. Plaster is then applied, typically using a wooden board as the application tool. The applicator drags the board upward over the wall, forcing the plaster into the gaps between the lath and leaving a layer on the front at the depth of the temporary guides, typically about 6 mm thick. A helper feeds new plaster onto the board, as the plaster is applied in quantity. When the wall is fully covered, the vertical lath “guides” are removed, and their “slots” are filled in, leaving a fairly uniform undercoat.

It is standard practice to apply a second layer in the same fashion, leaving about 12 mm of rough, sandy plaster (called a brown coat). A smooth, white finish coat goes on last. After the plaster is completely dry, the walls are ready to be painted. The curls of plaster that project through the gaps between the laths are called keys and are necessary to keep the plaster on the lath. Traditional lime-based mortar/plaster often incorporates horsehair which reinforces the plasterwork, thereby helping to prevent the keys from breaking away.

Eventually, the wood laths were replaced with rock lath (also known as “button board”), which is a type of gypsum wall board with holes spaced regularly across it. The holes serve the same purpose as the spaces between the wood lath strips, allowing plaster to ooze through the board when applied, making the keys to hold the plaster to the wall board.

In addition to rock lath, there were various types of diamond mesh metal lath which are categorised according to weight, type of ribbing and whether the lath is galvanised or not.

#### **2.1.2 NZSEE recommendations**

NZSEE (2006) stated that the design strengths of timber-framed stud walls with wood or metal lath and plaster was 4 kN/m each side whereas gypsum wall board with unblocked edges had a design strength of 3 kN/m each side. It recommended that a strength

reduction factor,  $\phi$ , of 0.7 be used. Thus a wall lined on both sides with lath and plaster may be assigned a resistance of  $2 \times 4 \times 0.7 = 5.6$  kN/m.

If a wall lined on both sides with lath and plaster experiences a racking load equal to the design strength specified by NZSEE ( $2 \times 4 = 8$  kN/m), then from simple statics the design uplift force on the tension end of a 2.4 m high wall is  $8 \times 2.4 = 19.2$  kN. Some of the resistance to this uplift will be provided by the axial load on the wall and continuity construction at its ends. However, the writer considers that most upper storey walls in residential buildings will be unable to resist this uplift force unless specific hold-down hardware is added.

### **2.1.3 Porter and Cobeen's recommendations**

From a variety of sources, Porter and Cobeen (2009) estimated that plaster over wood lath had a peak capacity of 400 lb per foot (5.5 kN/m) and reached this capacity at 18 mm deflection (it is presumed the walls are lined on each face). This is similar to the recommended NZSEE design strength, given above, of 5.6 kN/m. This is twice as strong as their estimate for horizontal sheathed walls which reached their capacity at 75 mm deflection and were four times as strong as nominally-fixed gypsum wallboard, which they stated would reach its capacity at 12 mm deflection. From their references it would appear that the information on lath and plaster walls came from a paper by Schmid – however, the writer was unable to obtain a copy of this paper.

### **2.1.4 Anderson's tests**

Anderson (1981) performed monotonic racking tests on half-scale internal walls lined on each face with plasterboard (Specimen A and B), gypsum lath and plaster (Specimen C) and wood lath and plasterboard (Specimen D). The test rig tested two panels bolted together as per Figure 1. The writer considers that this setup does test the panels satisfactorily in shear but not overturning. Details of the walls and fixings are given in Figure 2 and Figure 3. No details were given of the gypsum plaster used.

Results are given in Table 1. In Specimen A the gypsum wallboard had horizontal joints and in Specimen B it had vertical joints. The results indicated that the specimen with vertical joints was stronger, but this may have been because the horizontal joint construction was a lot weaker than the taped plasterboard joints used nowadays.

The lath and plaster specimens were strongest, in particular the specimens made from wood lath having a strength of 13.6 kN/m.

The author stated that the 1981 Los Angeles Municipal Code gave design shear strengths of 2.92 kN/m for Specimen C and 1.46 kN/m for Specimen D.



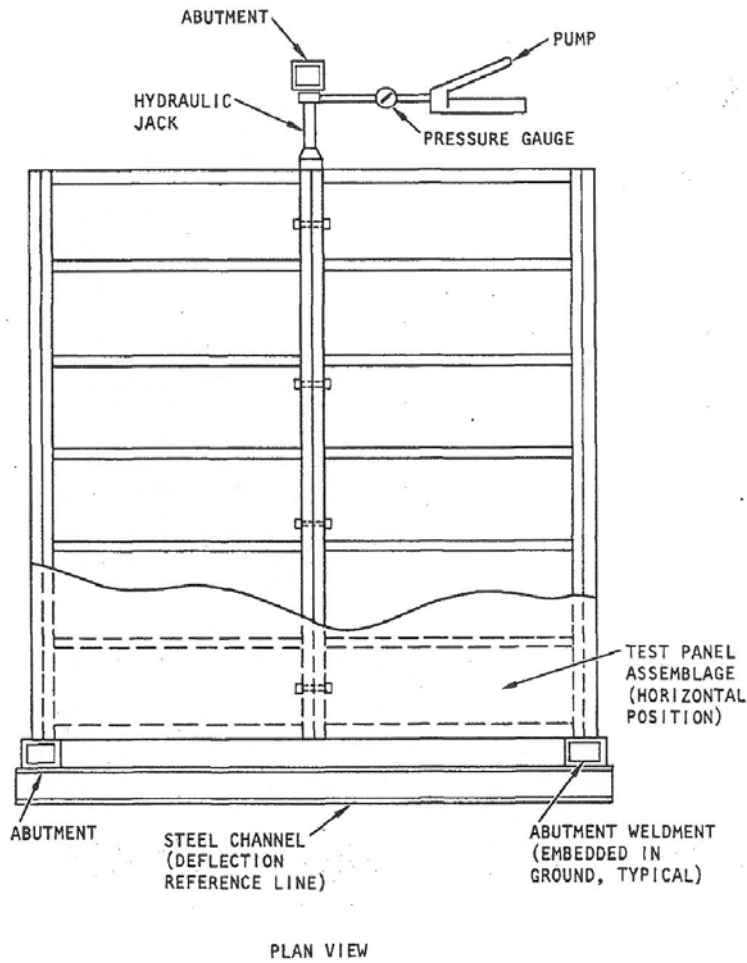

Figure 1. Anderson (1981) test rig

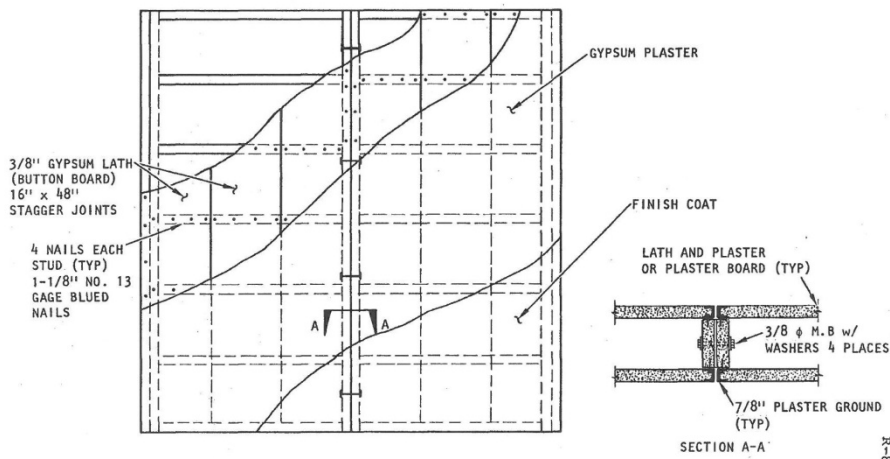

Figure 2. Anderson (1981) Specimen C – gypsum lath and plaster

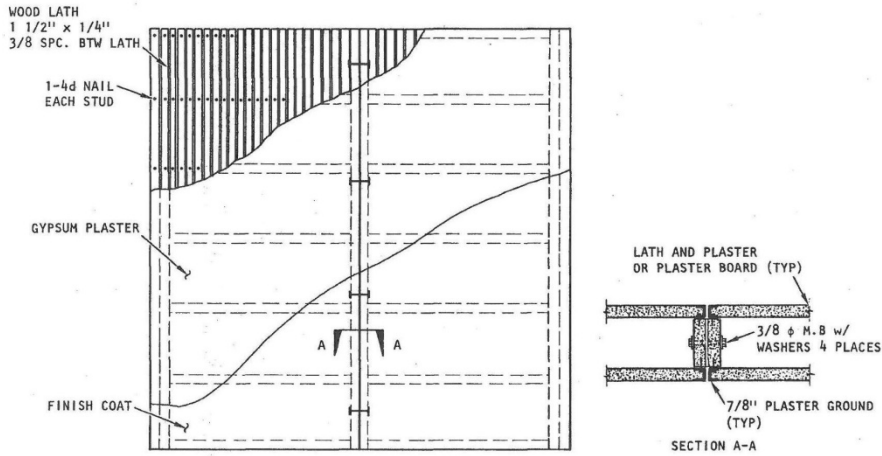

Figure 3. Anderson Specimen D – timber lath and plaster

Table 1. Shear wall strengths

Specimen	Shear Strength (kN/m)		
	1 <sup>st</sup> Crack	Yield	Ultimate
A	1.63	2.10	3.47
B	2.04	3.65	5.84
C	3.69	5.47	8.39
D	7.56	9.12	13.57

## 2.1.5 Shelton's insitu tests

Shelton (1993) performed racking insitu tests on a 3 m high x 2.8 m long wall lined with lath and plaster. Initially it contained a diagonal timber brace and was lined with lath and plaster on both sides. The wall was first isolated by removing the adjacent structure on the sides and top. The wall was tested in three stages. In each stage the test wall was cyclically racked to increasing displacements. Laths were 19 x 8 mm Rimu, with 11 mm gaps and were nailed to each stud. The plaster appeared to be a lime mixture with fibrous reinforcing with overall thickness of 45 mm.

Prior to the tests in Stage 1, the lath and plaster was removed from one side and replaced with high performance plasterboard. Uplift restraints were added at each end.

Prior to the tests in Stage 2, as damage to the lath and plaster was only observed in the top 600 mm, it was removed and replaced with plywood to transfer any horizontal load to a level 2.4 m above the floor. In addition, the plasterboard was replaced with weatherboard. The hysteresis loops indicated that the construction in Stage 2 had not reached peak strength before testing was stopped.

Prior to Stage 3 the lath and plaster was removed. Thus, only the construction with diagonal brace and weatherboard was racked.

In Stage 1, the average of the peak positive and negative resisted load was 23.5 kN and occurred at displacements between 22 and 32 mm. In Stages 2 and 3 the average peak loads were 24.5 kN and 12.5 kN respectively. This implies that the single side of the lath and plaster was resisting  $24.5 - 12.5 = 12$  kN (4.3 kN/m) and that it had a similar effectiveness to the high performance plasterboard as the resisted loads in Stage 1 and

2 were similar. The high performance plasterboard, when used with end straps, had a published wind rating of 4.75 kN/m.

## **2.1.6 Beattie's tests**

Beattie (2006) constructed and tested a 2.4 m x 2.4 m lath and plaster wall in the BRANZ laboratory. It was lined on one face only and did not contain a diagonal brace.

The lath and plaster wall was loosely based on what was found in old publications and the experience of the plasterer employed to construct the wall. Further research was undertaken to discover the materials used and the construction process for lath and plaster walls. Very often in the past, horse or ox hair was used to provide some tensile strength to the plaster. However, no hair was used in the construction of the laboratory specimen.

The wall framing was 90 x 45 mm radiata pine timber with studs at 400 mm centres. No nogs were installed.

Radiata pine laths, of 35 x 8 mm cross-section, were fitted horizontally, with 8 mm gaps between them to simulate old style construction. They were fixed with 25 mm long flat-head galvanised clouts at each stud and two clouts where they were joined on the same stud.

The first plaster coat consisted of 16 parts sand and four parts hydrated lime and one part cement by volume. Water was added to achieve the required consistency. Compression cylinders were made, stripped and air-cured beside the test specimen and had a measured mean compressive strength of 2.0 MPa at 21 days. The coat was applied to an approximate thickness of 7 mm from the outside face of the timber laths. The plaster was squeezed between the laths to form a key, with the wall structure and the surface of the plaster roughened with a coarse-toothed metal comb to form a key for the following coat. When viewed from the back of the wall, the plaster that had been forced through the gaps during construction was still in place.

The second plaster coat consisted of one to five sand to lime by volume. Lime plaster takes several years to achieve its full strength, but this could not be easily replicated in the test. Water was added to obtain the required consistency. This coat was applied to make a total thickness of approximately 18 mm from the outside face of the timber laths. One half of the plaster was towelled to a fairly smooth finish, while the other half was roughened in a similar manner to the previous coat. The 22-day strength of 0.2 MPa was very low.

The third plaster coating (the finishing coat) consisted of two to three casting plaster to hydrated lime with water added to achieve the required consistency. The coating was applied to a thickness of approximately 2 to 3 mm. This coating was only applied to the section of the wall with the roughened surface. The previous coat was still damp below the surface and could be deformed by applying firm finger pressure.

Beattie performed a racking test on the wall when the first coat was 22 days old. During the first half cycle to 5 mm, the top thirds of the plaster over the lath began to detach from the lath. When the direction of displacement was reversed, little further damage was observed. However, during the next cycle to +5 mm, large sections of the plaster fell from the wall. It appeared that the strength of the first coat was insufficient to prevent the plaster from shearing on a plane at the front face of the laths.

The hysteresis loops measured by Beattie are shown in Figure 4. The average of the push and pull peak strength was 2.66 kN or 1.11 kN/m for this lath and plaster wall lined on one side only. However, as the wall reached peak strength at such a low displacement (approximately 5 mm) it is doubtful if any bracing strength can be utilised.

As Beattie's results gave lath and plaster strengths so much lower than tested elsewhere, a further BRANZ test was performed as part of this study as described in Section 3.2. One reason for the low result by Beattie could have been the low plaster strength achieved at the time of testing as lime takes a long time to achieve a good strength. Beattie tried to compensate for this by adding a small proportion of cement.

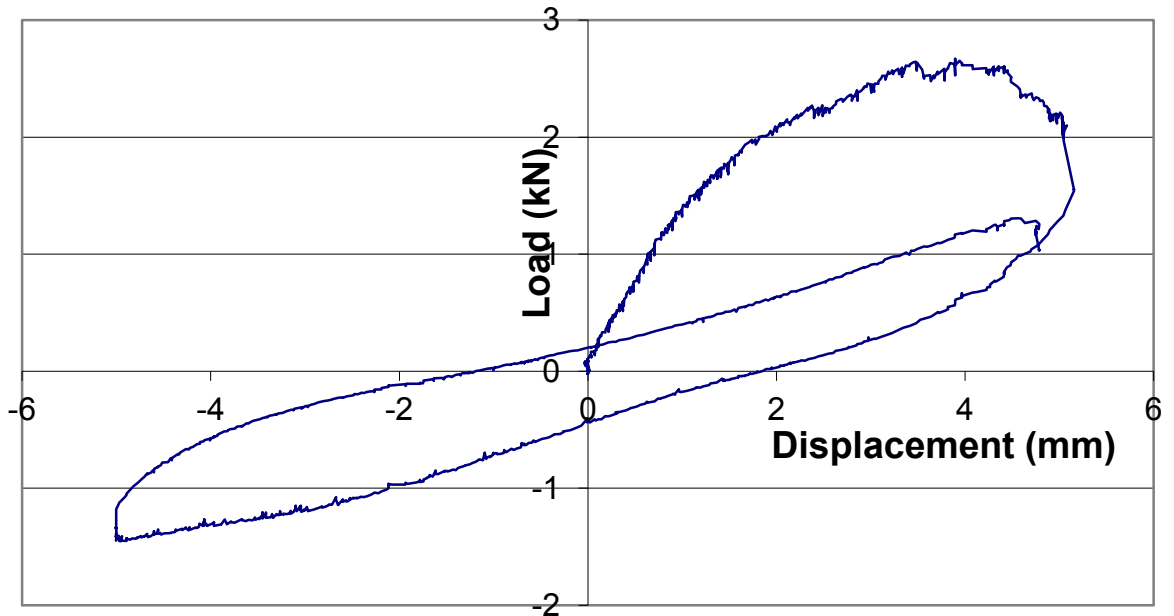

Figure 4. Beattie (2006) racking hysteresis loops for the 2.4 m wide lath and plaster wall

## 2.1.7 Literature survey

(a) Buchanan et al (2011)

Buchanan et al reported on damage from the February 2011 Christchurch earthquake. They noted that the use of lath and cement plaster on the exterior of houses was common in the early 1900s for producing a stucco style exterior finish. They considered that the product was very stiff but could not be relied upon for strength. They had observed cases where sheets of the plaster had detached cleanly from the lath (Figure 5). In this photograph the main diagonal timber bracing for the house can be seen where both the plaster and the lath have broken away from the wall.

From their observations they concluded that wall linings of trowelled plaster on closely-spaced wood lath had sustained considerably more damage than plasterboard sheet linings. There was a concentration of damage around window and door corners. Because it is not a panel system like plasterboard, the pattern of cracks was sometimes more distributed and not localised around seams in panels, as shown in Figure 6.



**Figure 5. View of an earthquake-damaged lath and plaster exterior wall (Buchanan et al 2011)**



**Figure 6. View of an earthquake-damaged interior lath and plaster wall (Buchanan et al 2011)**

(b)Pang et al (2012)

The authors used the results from a 1950s Forest Product Laboratories test for walls with plaster on wood lath for their computer model. The model assumed that the lath and plaster had a strength of 5.99 kN/m and reached peak strength at 17 mm deflection. It is presumed the walls had horizontal lath and plaster on both sides and did not contain a diagonal brace.

(c)Matsumoto et al (2012)

Laboratory tests were performed on three shear walls with diagonal wooden lath and plaster on one side and siding on the other. The siding was removed on one specimen part way through the tests. In a fourth specimen plasterboard was used instead of the lath. The siding contributed approximately 30% to the strength. The plaster increased the initial stiffness by a factor of 2.4 but did not contribute to the ultimate strength. The wall strength under cyclic loading was 12.9 kN/m of which 9 kN/m can be attributed to the plastered wooden diagonal lath.

## **2.2 Fibrous plaster walls**

Buchanan et al (2011) stated that fibrous plaster is a type of gypsum plasterboard sheet made with a mixture of long fibres for reinforcing, but no paper facing. The sheets were usually joined at the edges of door and window openings, and no reinforcing tape was used at sheet junctions. The product fitted within the description of a generic bracing system in the early versions of NZS 3604. It was common for these joints to crack and the fixings to “pop” (i.e. pry off the plaster plug from over the fixing head) during the earthquake. The writers stated that bracing ratings based on testing were available from the Fibrous Plasterers Association.

### **2.2.1 Literature survey**

(a)Cooney (1979)

Cooney stated that during the 1920s and 1930s first fibrous plaster sheets and then paper-faced gypsum board sheets were introduced. The bracing effect that could be obtained from these sheets was not recognised or provided for in the regulatory bracing provisions up to and including NZSS 1900. Since the 1930s paper-faced gypsum board became the predominant wall lining material with other wood-based materials being used increasingly in recent years.

(b)Ireland et al (2009)

The authors reported on in-situ bracing tests on timber-framed walls lined on both sides with 16-20 mm thick fibrous plaster in a large 1910 structure. Two isolated portions of the walls (3.2 m long and 2.4 m high) were tested by BRANZ. Uplift was effectively precluded by utilising the weight of the structure above. Fixings from the fibrous plaster to the wall framing are unknown. Wall 1 had two diagonal braces consisting of short members cut to fit between studs (Figure 7) whereas Wall 2 had a single diagonal brace fitted into cut-outs in the studs. Testing was stopped before damage to adjacent historic fabric occurred. Test results are shown in Figure 8 and Figure 9. The displacement gauge ran out of travel at approximately 11 mm with Wall 2 and thus the plot shows a steep rise in load without a corresponding increase in displacement at this stage. The average of the push and pull loads resisted was 25 kN (i.e. 7.8 kN/m) with Wall 1 and 19.9 kN (i.e. 6.2 kN/m) with Wall 2. Greater strengths are likely to have occurred if the walls had been racked further. Some of this resistance was due to the diagonal braces but most is expected to have been due to the fibrous plaster lining – particularly in the early stages of testing.



**Figure 7. Wall 1 framing in the insitu fibrous plaster wall tests**

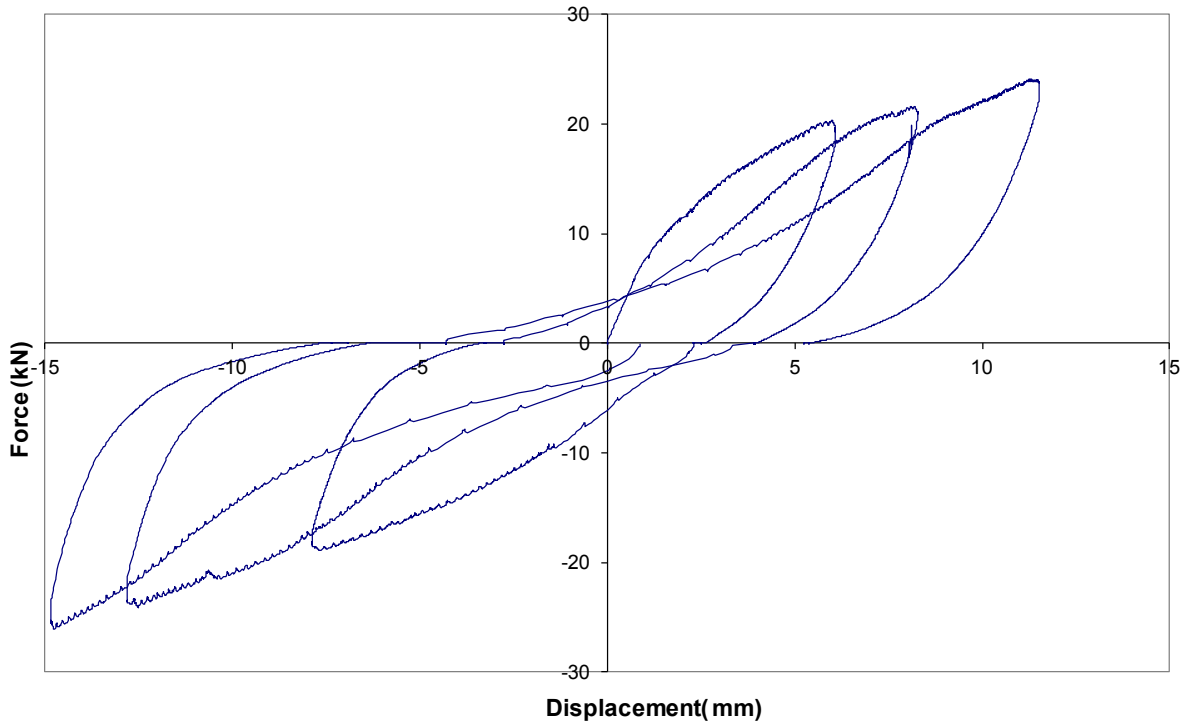

Figure 8. Fibrous plaster Wall 1 hysteresis loops

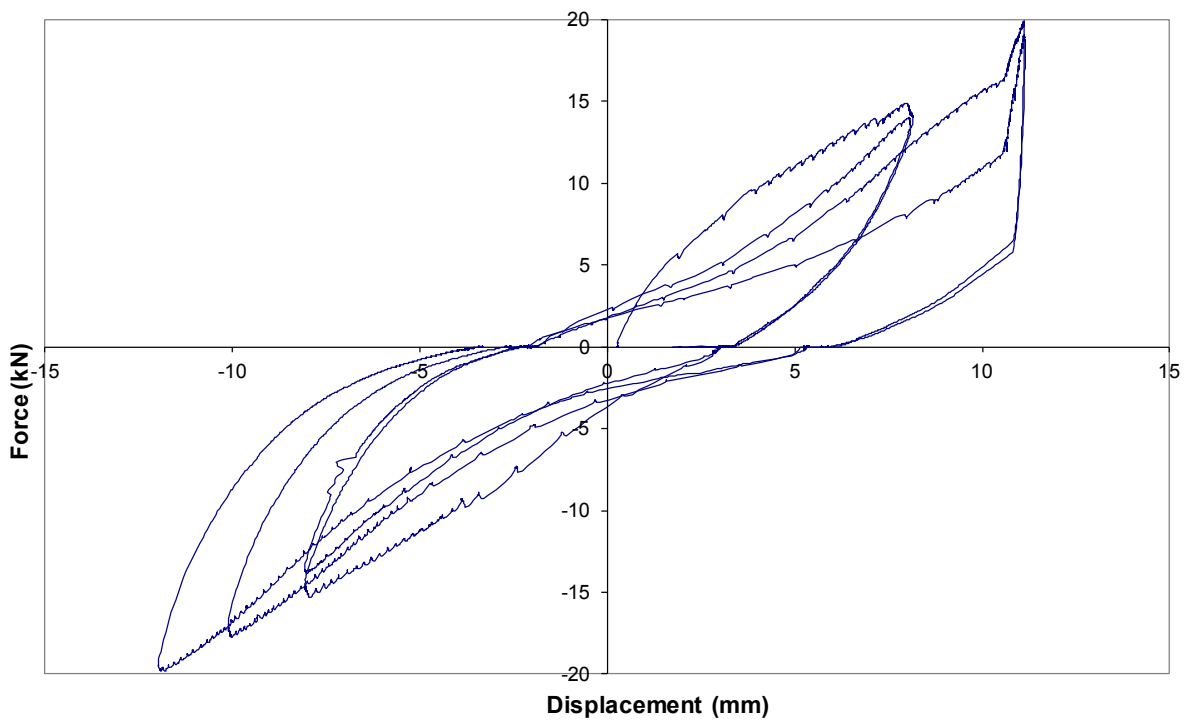

Figure 9. Fibrous plaster Wall 2 hysteresis loops

## 2.3 Diagonal braces

### 2.3.1 Literature survey

(a) Cooney (1979)



Cooney stated that during the 1930s diagonal braces were permitted to be reduced in size to 100 x 25 mm (4 x 1 inch) in single-storey houses and then in practice gradually this size also crept into the lower storeys of houses in some areas. Also, as window sizes increased it became more difficult to provide braces in continuous lengths between top and bottom plates. Contrary to the intent of the regulations (which required that walls be “braced through their full height at an angle as near to 45° as practicable” and that cut-between braces were required to be in one continuous alignment), “dogleg” or “K” braces were introduced and accepted in external walls. In more recent times the 100 x 25 mm braces have been replaced with 22 x 22 x 1.2 mm cold-formed galvanised steel angle braces. The basis for acceptance of this metal brace instead of the timber brace was that the overall racking performance of a typical 2.4 m square wall frame, both lined and unlined, was not substantially different, even though the metal angle brace itself had greater strength and stiffness in tension and less strength in compression than the timber brace. These comparative evaluations were carried out on studs spaced at 450 mm centres and when studs were spaced at 600 mm centres for internal non-load bearing walls and some external walls, the relative effectiveness of the metal angle in compression was virtually unchallenged.

## **2.4 Plasterboard bracing systems**

### **2.4.1 NZS 3604**

Appendix K of NZS 3604 (1990) prescribes that gypsum-based material (which could include fibrous plaster) not less than 8 mm thick and fixed to framing members at not less than 10 mm from the sheet edge with 30 x 2.5 mm flat-head nails at 150 mm centres and at 400 mm to intermediate studs, and which contains a specific diagonal brace or braces, may be assigned the following bracing strengths:

**Table 2. Bracing ratings which can be used with fibrous plaster walls**

<b>Principal bracing element</b>	<b>Secondary bracing element</b>	<b>Rating (kN/m)</b>
Sheet material one side	Set 1	2.1
Sheet material one side	Set 2	1.5
Sheet material two sides	Set 1	3.1
Sheet material two sides	Set 2	2.35

To use the bracing values in Table 2 a defined diagonal brace (called Set 1 or Set 2 in this report) was required.

## **2.5 Timber shear walls**

### **2.5.1 NZSEE recommendations and comments**

NZSEE (2006) states that the strength of these shear walls should be based on an assessment of the materials making up the particular shear wall and their individual strengths. Depending on the type of shear wall, the NZSEE provides formulae that can be used to determine the diaphragm strength in the absence of test results.

For many shear walls, the major component affecting the stiffness is the nail slip. In the case of initial assessment, it is sufficiently adequate to base the stiffness on the nail slip component of deformation.

NZSEE provided the following comments (a to d below) for the following types of timber shear walls:

(a) Transverse sheathing

This consists of 25 or 50 mm thick boards, usually 100-200 mm wide, nailed in a single layer at right angles to the studs.

The sheathing resists the in-plane shear force caused by lateral loading. The end studs carry axial loading from the gravity and the lateral loads whereas the intermediate studs only carry gravity loading.

NZSEE considered that nail slip was the dominant cause of lateral deflection in these shear walls. Flexural strains in the chord members and shear distortion in the sheathing itself also contributed to the total deflections.

(b) Single diagonal sheathing

The shear force applied to the shear wall is carried by tension or compression in the 45° diagonal sheathing and is transferred to the perimeter members by the nails.

(c) Double diagonal sheathing

Two layers of sheathing on the same side of the framing significantly improve the shear characteristics of a shear wall. When double diagonal sheathing is used, one layer acts in tension and the other in compression and the shear is assumed to be shared; thus, the two layers act as a shear membrane.

(d) Panel sheathing

This consists of wood structural panels, such as plywood or oriented strand board, placed on framing members and nailed in place. Different grades and thicknesses of wood structural panels or gypsum board may have been used on each side of the wall, depending on requirements for gravity load support, shear capacity and fire protection. Edges at the ends of the structural panels are usually supported by the framing members. Edges at the sides of the panels can be blocked or unblocked.

Nailing patterns and nail size can vary greatly. Nail spacing is commonly in the range of 75 to 150 mm on centre at the edges of the panel and 250 to 300 mm in the panel interior.

## **2.5.2 Cooney**

Cooney (1979) stated that prior to the 1930s virtually all houses were lined internally with horizontal boarding, scrim, lining paper and wallpaper.

Such boarding was double-nailed at each stud crossing and, whilst no mention of the effectiveness of this boarding on the bracing performance of walls appears to have been made, it is likely to have been considerable.

## **3. BRANZ TESTS**

### **3.1 Systems tested**

Table 3 summarises the details of the bracing systems tested at BRANZ in order to obtain up to date bracing ratings for common generic systems.

**Table 3. Summary of details of bracing systems tested**

Label	Bracing System	Strengthening	Fixing	Nogs	Fixing Pattern	Wall Length (m)
Lath1	45 x 6 lath and plaster wall with no horse hair	None	TypeE	No	Type 6	2.4
Brace1	150 x 25 let in brace at 45°	None	TypeC	No	Type2	2.4
		Type1				
Brace2	90 x 45 single brace cut between studs	None	TypeD	No	Type3	2.4
		Type1				
Brace3	90 x 45 double brace cut between studs	None	TypeD	No	Type3	2.4
		Type1				
Brace4	Dogleg brace	None	TypeD	@600	Type3	0.6
		Type1				
Board1	200 x 10 horizontal board	None	TypeF	No	Type7	1.2
Board2	140 x 20 bevel back weatherboard	None	TypeG	Yes	Type5	2.4
Sheet1	Standard plasterboard one side only	None	TypeA	Yes	Type1	1.2
Sheet2	Standard plasterboard two sides	None	TypeA	Yes	Type1	1.2
Sheet3	3.2 mm tempered hardboard one side only	None	TypeH	Yes	Type4	1.2
		Type2	TypeA	Yes	Type4	1.2
		Type3	TypeA	Yes	Type4	1.2
Sheet4	Horizontal corrugated steel	None	TypeI	Yes	Type8	2.4
Sheet5	Vertical corrugated steel	None	TypeI	Yes	Type9	2.4

**Legend**

**Fixing**

- (A) 30 x 2.5 galvanised flat-head nails
- (C) 75 x 3.15 galvanised flat-head nails
- (D) 75 x 3.15 bright jolt-head nails
- (E) 25 x 2.5 galvanised flat-head clouts
- (F) 40 x 2.8 galvanised flat-head nails
- (G) 60 x 3.15 bright jolt-head nails
- (H) 30 x 1.6 electroplated panel pins
- (I) Lead heads nails with 60 x 3.5 bright shanks

**Fixing Pattern**

- ✓ (1) A nail at each corner and then at 300 mm centres to all studs and plates
- ✓ (2) Two nails brace to each stud and three nails brace to each plate
- ✓ (3) Two nails each end of braces
- ✓ (4) A nail at each corner and then at 200 mm centres to all studs and plates
- ✓ (5) Weatherboards fixed to studs with a single nail at 40 mm from the bottom of each weatherboard
- ✓ (6) Laths fixed with a single nail
- ✓ (7) Two nails at each board/stud intersection
- ✓ (8) Nails used at every second ridge to studs below except third ridge one side of lap.
- ✓ (9) Nails used at every second ridge to nogs and plates below except third ridge one side of lap.

**Strengthening**

- ✓ (1) Strap at brace top between top plate and end stud
- ✓ (2) Replace panel pins with 30 x 2.5 nails
- ✓ (3) Add 100% rocking restraint

Unless stated otherwise, 2.42 m high timber frames were constructed using 90 x 45 mm kiln-dried MSG 8 radiata pine timber with plates nailed to studs with two 90 x 3.15 mm power-driven glue-shank nails. It is recognised that these do not correspond with the timber and nails used in bygone days but it is considered that the difference in performance would be small.

The bottom plates of the walls were fixed to the foundation beam using pairs of 100 x 4 mm hand-driven galvanised nails at 600 mm centres starting 150 mm from the outside stud.

Nogs were used where noted in Table 3. These were at 800 mm centres except for system Brace 4 where they were at 600 mm centres.

Studs are at 600 mm centres (although were often at 18 inch centres [450 mm centres] in practice) except for Lath 1 where they were at 400 mm centres.

Each specimen was subjected to three cycles of in-plane displacement at top plate level to each of  $\pm(8.5)$  mm,  $\pm 15$  mm,  $\pm 22$  mm,  $\pm 29$  mm,  $\pm 36$  mm,  $\pm 43$  mm and  $\pm 65$  mm.

A standard P21 end restraint was used to help resist panel rocking using three power-driven 90 x 3.15 mm nails in the P21 end connection fixed to the framing before the bracing system was attached.

## **3.2 Lath and plaster (Lath 1)**

Based on Beattie's work (2006), Section 2.1.6, it was considered that the plaster placed over the lath contributed little to the strength of the wall as this fell off so readily. Hence, the specimen now described was constructed with only one thickness of plaster. It did not contain any diagonal braces.

The wall framing was 90 x 45 mm radiata pine timber with studs at 400 mm centres. No nogs were installed. Radiata pine laths, of 45 x 6 mm cross-section, were fitted horizontally, with 10 mm gaps between. They were fixed with 25 mm long flat-head galvanised clouts at each stud and two clouts where they were joined on the same stud. Guides of 6 mm thickness were added to facilitate screeding the plaster coating as shown in Figure 10.

The plaster coat consisted of 12 parts with four parts hydrated lime and one part cement by volume. Water was added to achieve the required consistency. The coat was applied to an approximate thickness of 6 mm using a screeding action from the outside face of the timber laths as shown in Figure 10. The plaster was squeezed between the laths to form a key, with the wall structure as shown in Figure 11.



**Figure 10. Applying plaster to the lath and plaster test wall**



**Figure 11. Plaster squeezed between laths**

After three days cylinders formed from the plaster were stripped from their moulds and cured in sealed plastic bags. These were kept beside the specimen until testing. A racking test was performed on the wall when the first coat was 57 days old. The plaster cylinders were compression-tested six days later by the Materials Advisory and Testing

Service. Five cylinders had a compressive strength of 1.8 MPa and the sixth cylinder had a compressive strength of 1.7 MPa. These were slightly less than achieved with the plaster mix in Beattie's tests where the mean compressive strength was 2.0 MPa. The plaster coating exhibited some fine diagonal shrinkage cracks prior to testing.

During the single cycles to both 2 and 4 mm the plaster shrinkage cracks widened and then re-closed at unload. Some plaster curls (keys) fell during the three cycles to  $\pm 8$  mm. Extensive plaster cracking occurred during cycling to  $\pm 12$  mm. Large areas of plaster fell during cycling to  $\pm 16$  mm.

The hysteresis loops measured are shown in Figure 12. The average of the push and pull peak strength was 4.9 kN at 12 mm displacement (2 kN/m) which is approximately twice the strength achieved by Beattie but still only 50% of the design strength of 4 kN/m recommended by NZSEE (2006). The difference may be due to the hair used in the old mixes which is likely to have helped resist the curls (also called keys) from falling off. Thus, before the values in the NZSEE (2006) recommendations are used, the plaster should be examined to ensure it contains a good proportion of such hair.

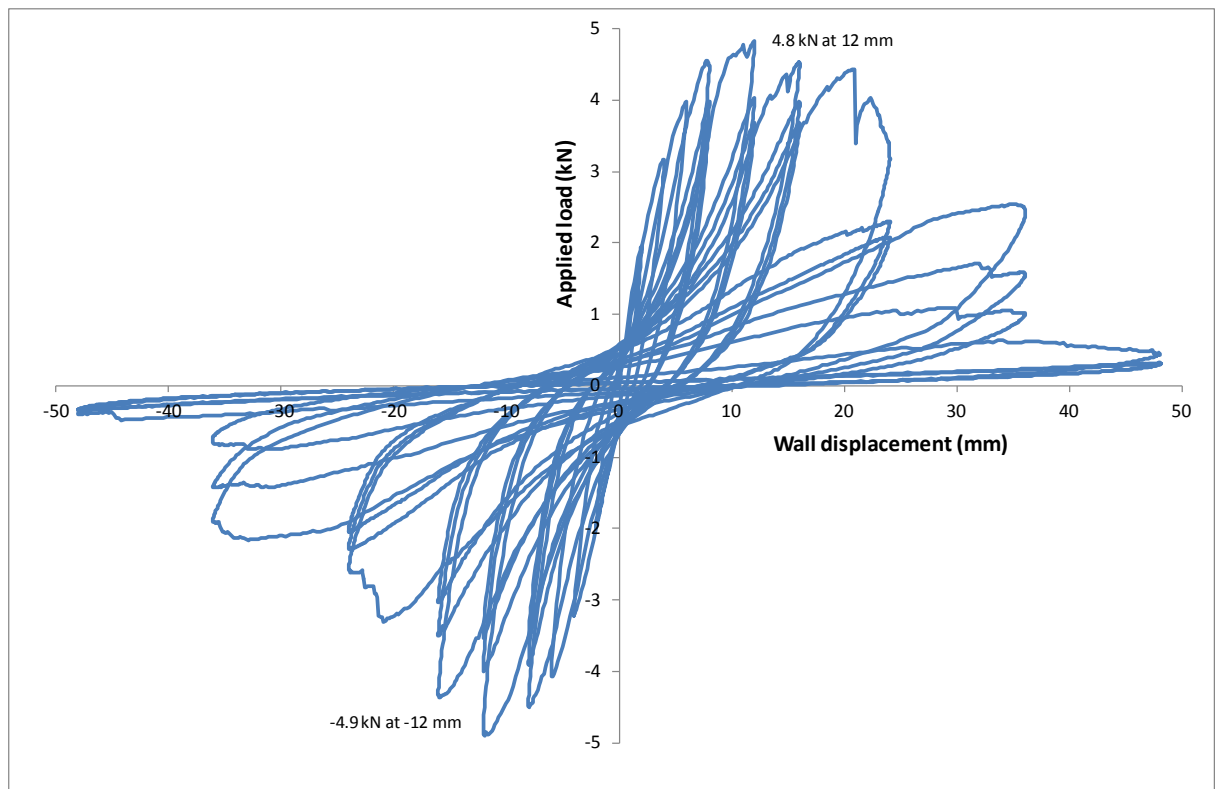

Figure 12. Racking hysteresis loops for the 2.4 m wide lath and plaster wall

### 3.3 Brace 1: 150 x 25 let in brace at 45° (Brace 1)

The 150 x 25 mm timber brace was fitted into slots cut into the timber studs and plates as shown in Figure 13 to Figure 14. Three 75 x 3.15 mm galvanised flat-head nails were used to connect the brace to the top and bottom plates as shown in Figure 14 and two of these nails fixed the brace to intermediate studs as shown in Figure 15. The brace was in compression during the push cycle and lifted the top plate as shown in Figure 16. This was clearly limiting the specimen strength as shown in Figure 17. A repair was performed, which conceivably could be done during building renovations. The joint still failed as shown in Figure 18 but the resisted strength was significantly greater as shown

in Figure 20. Also shown in Figure 20 is the backbone curve from Figure 17. It can be seen that the specimen after strengthening was less stiff due to the prior testing but was otherwise unaffected by the stiffening for the direction with the brace in tension and the strengthening was very effective with the brace in compression.

At large displacements the nails pulled out of the timber framing and diagonal brace as shown in Figure 19. This limited the maximum tension force in the brace. The maximum bracing force in the pull direction (brace in tension) was approximately 2.6 kN and the strength was limited by the nailed fixing of the diagonal brace to the wall framing. The maximum compression force in the brace was greater due to the load transfer at the top and bottom of the brace. However, when this failed the resisted load dropped and plateaued to 1.56 kN – i.e. less than for the brace in tension. Peak loads resisted are given in Table 4.



**Figure 13. Specimen for 150 x 25 let in brace at 45°**



**Figure 14. Joint at top plates in specimen for 150 x 25 let in brace at 45°**



Figure 15. Joint at intermediate studs in specimen for 150 x 25 let in brace at 45°



Figure 16. Diagonal brace lifts top plate in tests before connection strengthening

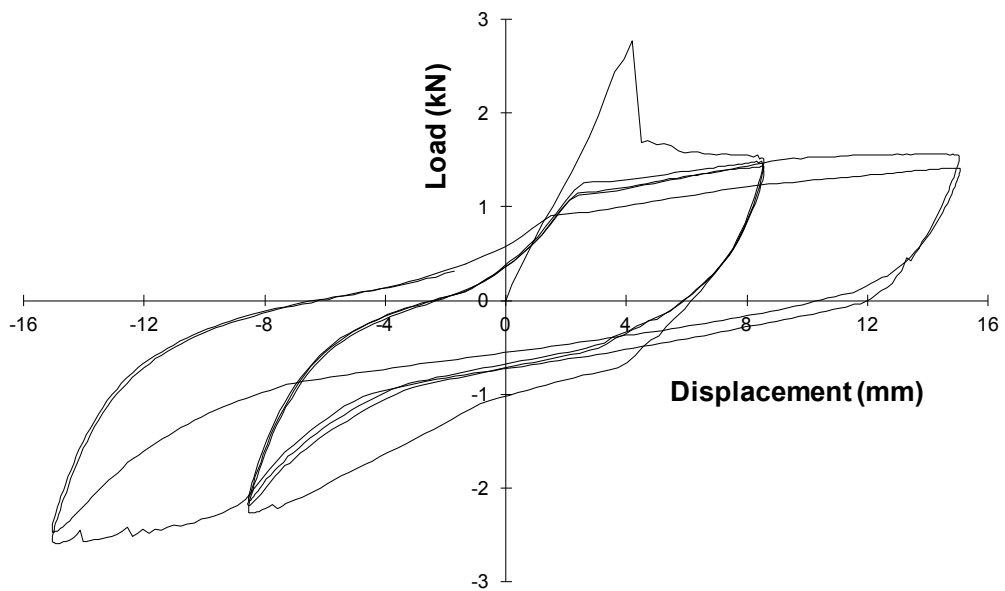

Figure 17. Hysteresis loops for 150 x 25 let in brace at 45° before connection strengthening





**Figure 18. Diagonal brace lifts top plate in tests after connection strengthening**



**Figure 19. Nails pull out of diagonal brace connection**

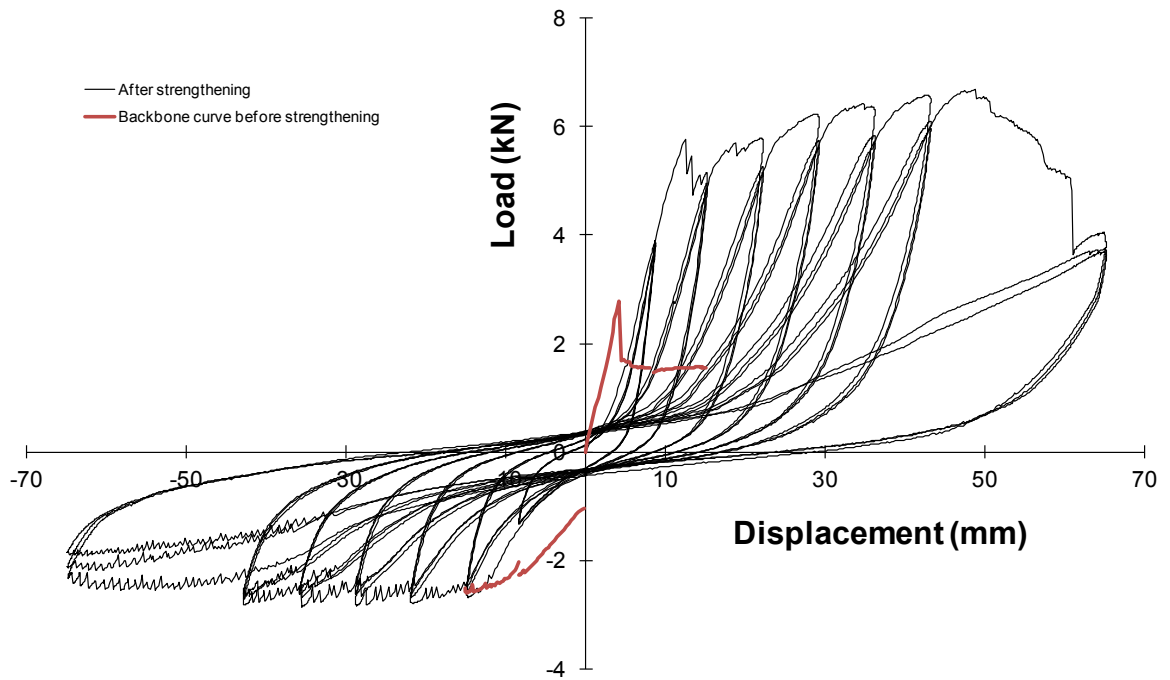

Figure 20. Hysteresis loops after connection strengthening

Table 4. Peak loads resisted by the Brace 1 system

Construction	Brace in compression	Brace in tension
Before strengthening	2.78 kN	-2.59 kN
After strengthening	6.68 kN	-2.85 kN

### 3.4 90 x 45 single brace cut between studs (Brace 2)

The single 90 x 45 mm diagonal brace in the 2.4 m long wall actually consisted of four short braces each of which was hand-nailed to the intermediate studs and/or the top or bottom plates using two 75 x 3.15 mm bright jolt-head nails at each end. Views of the joints are shown in Figure 22 and Figure 23. At the plates the braces were notched into the corner as shown in Figure 23. The nails were vertical at the top and bottom plates and approximately 22° to the horizontal at the intermediate studs as shown in Figure 24. The braces were made a tight fit. In practice, timber shrinkage as well as less accurate construction may have resulted in some slop.

During the initial push cycles to 8 mm, it was noted the diagonal brace was lifting the top plate. The test was stopped and two additional nails added between top plate and stud. Unfortunately, the test data for this loading was lost. The test was restarted from the initial position. During the remainder of the test the top plate did not separate from the studs.

The load versus displacement hysteresis loops are shown in Figure 25. The peak resisted push load (brace in compression) was 2.90 kN and the peak resisted pull load was 1.04 kN. The diagonal brace joints opened in tension as shown in Figure 26 and slipped vertically in compression as shown in Figure 27. They finally almost fully separated in tension and then were pushed apart in compression.



**Figure 21. Specimen for single brace at 45° cut between studs**



**Figure 22. Centre joint in specimen for single diagonal braces cut between studs**



**Figure 23. Bottom joint in specimen for single brace at 45° cut between studs**

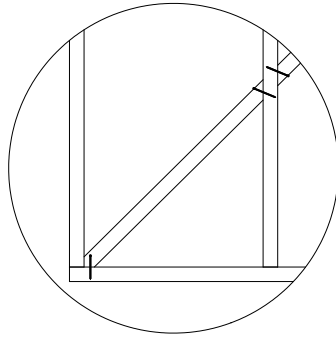

Figure 24. Nailing on the diagonal braces in specimen for single brace at 45° cut between studs

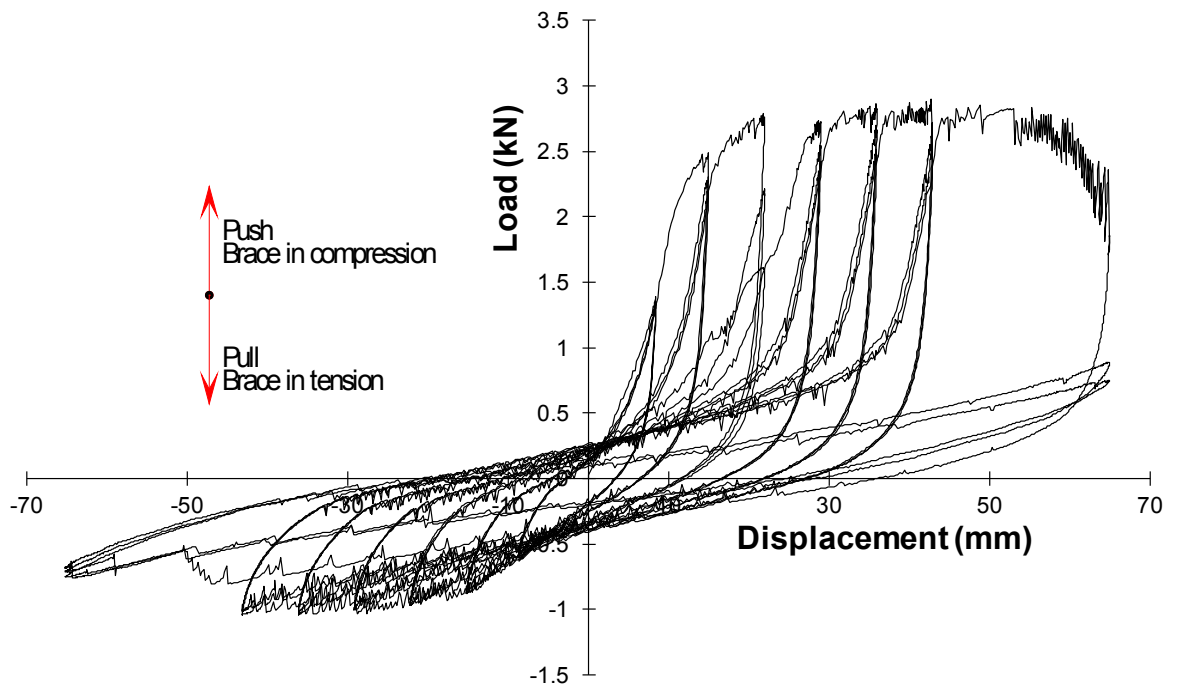

Figure 25. Hysteresis loops for specimen with single brace at 45° cut between studs



Figure 26. Brace in tension

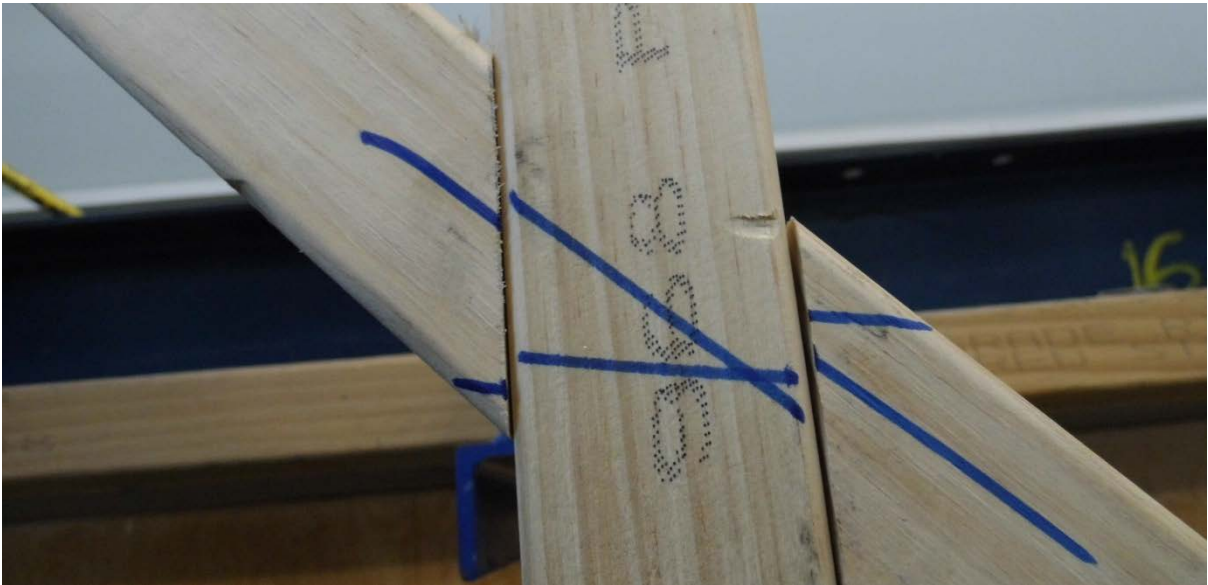

Figure 27. Brace in compression

### 3.5 90 x 45 double brace cut between studs (Brace 3)

This 2.4 m long wall consisted of two braces in opposing directions as shown in Figure 28. They were constructed in a similar manner to that described in Section 3.4. The detail at the intersection of the braces is shown in Figure 29 and Figure 30.

The diagonal braces lifted one end top plate at an early stage of testing. The hysteresis loops at this stage are shown in Figure 31. An end strap like the one shown in Figure 32 was added at each end and the test repeated. The hysteresis loops from this additional testing are shown in Figure 33. Also shown in this plot are the backbone curves from Figure 31 for comparison.

The diagonal braces opened up when they were in tension in a similar manner to Brace 2 and an example is shown in Figure 34. Little movement occurred in the joint at the intersection of the diagonal braces as shown in Figure 35. Peak loads resisted are summarised in Table 5.



Figure 28. Specimen for double diagonal braces cut between studs



Figure 29. Centre joint in specimen for double diagonal braces cut between studs

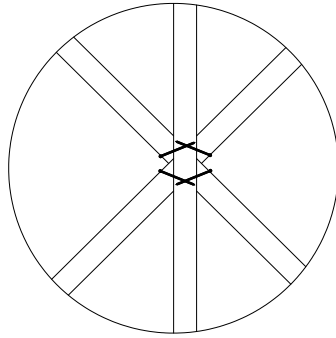

**Figure 30. Nailing at the junction of the diagonal braces in specimen for double diagonal braces cut between studs**

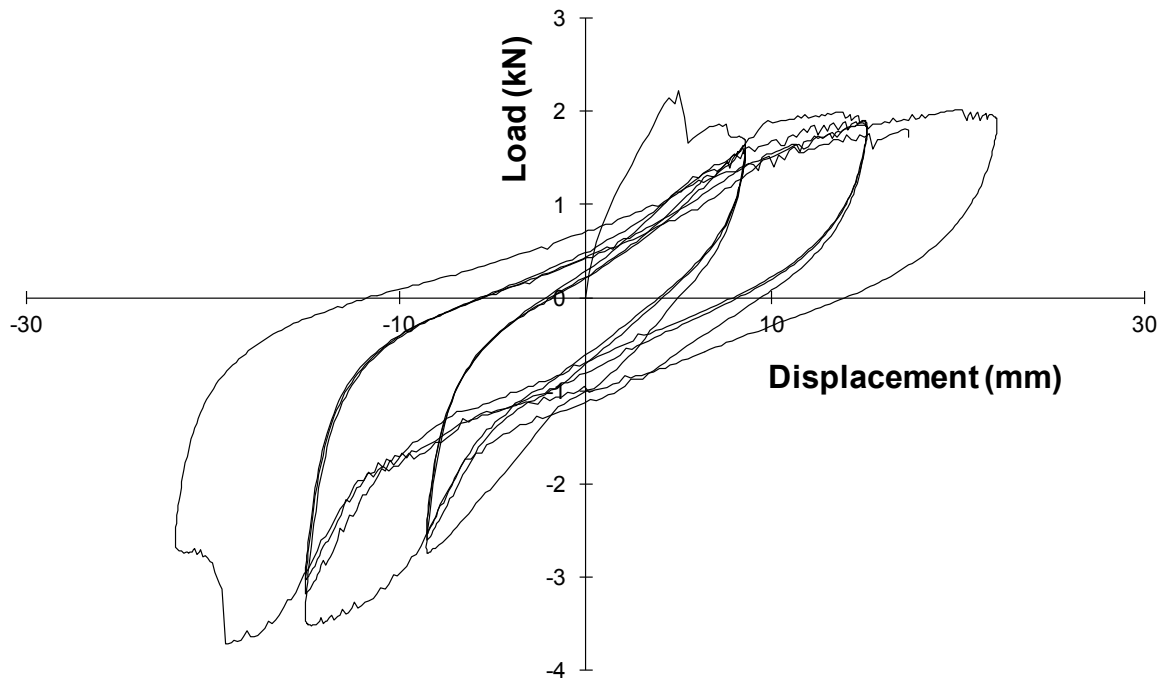

**Figure 31. Hysteresis loops for Brace 3 before strengthening**

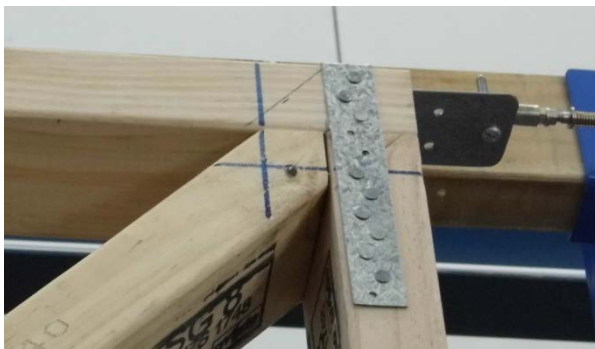

**Figure 32. Strap added to Brace 3 after top plate lifted**

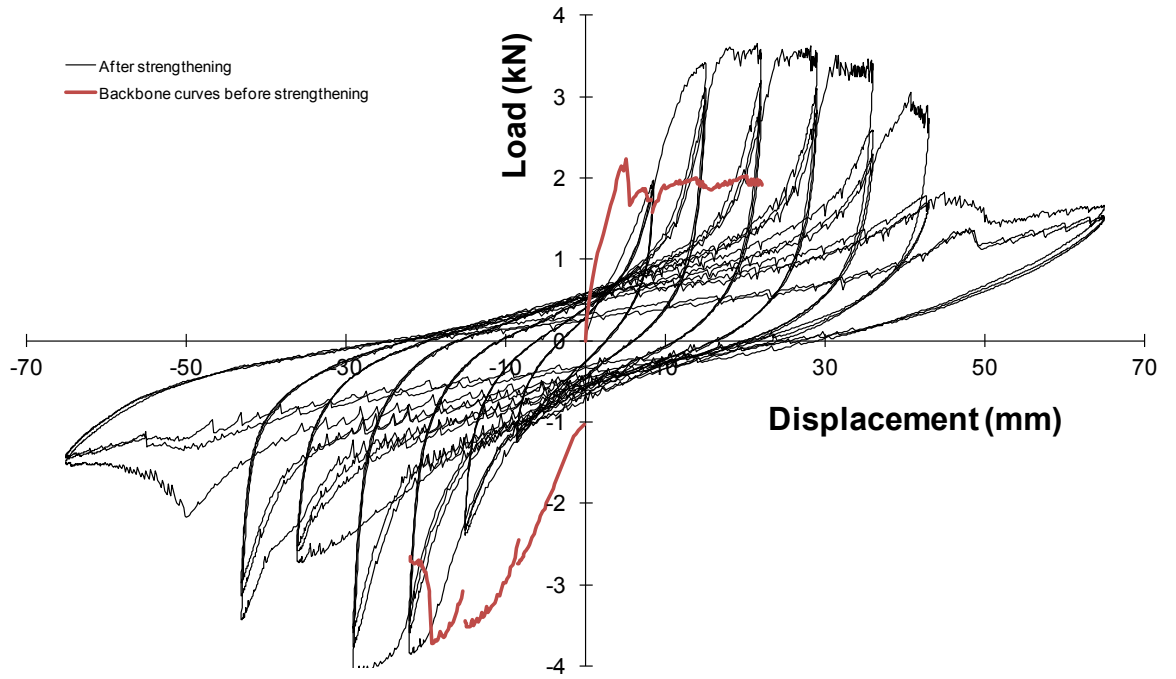

Figure 33. Hysteresis loops for Brace 3 after strengthening

Table 5. Peak loads resisted by the Brace 3 system

Construction	Push	Pull
Before strengthening	2.23 kN	-3.73 kN
After strengthening	3.65 kN	-4.10 kN

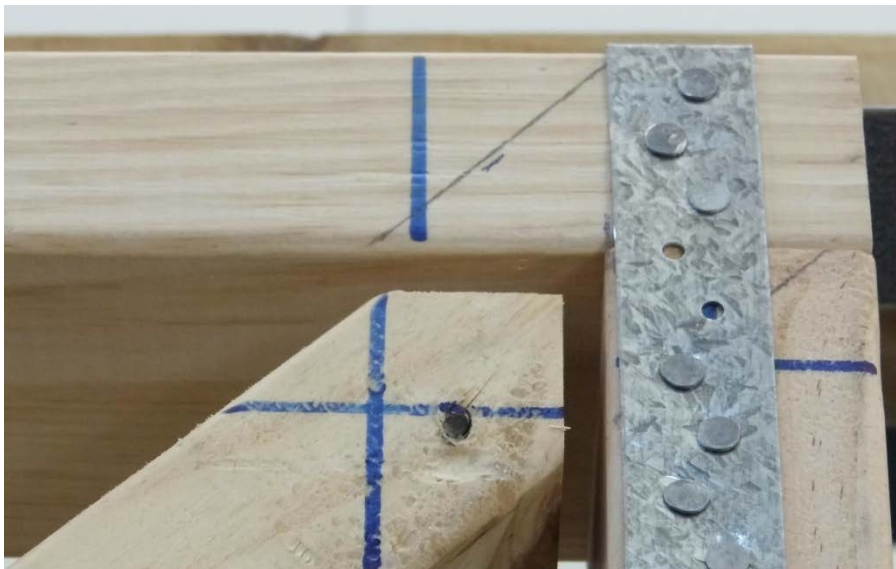

Figure 34. Gaps opened at joints in tension in Brace 3 after strengthening





**Figure 35. Little joint movement occurred at the intersection of diagonal braces (photograph taken at same stage as Figure 34)**

### **3.6 Dogleg brace (Brace 4)**

This 0.6 m long wall had nogs at 600 mm vertical centres with a short length of diagonal timber brace between nogs. Each brace was hand-nailed to the adjacent nogs in the vertical direction using two 75 x 3.15 mm jolt-head nails at each end. Two 75 x 3.15 mm jolt-head nails placed horizontally through the studs fixed them at each end of the nogs. The braces were notched into the corners as shown in Figure 36. The braces were made a tight fit although timber shrinkage in practice, as well as less accurate construction, may result in some slop being present in actual construction.

Under pull loading the top brace was in compression. At approximately 12 mm pull displacement the top plate was lifted by the diagonal brace. It was not lifted by the racking in the push direction. Under push loading the top brace was in tension as shown in Figure 37. Both end top plate to stud joints were strengthened after the specimen had been through  $\pm 28$  mm displacement as shown in Figure 38 and the full programme of cycling restarted from scratch.

The racking load versus racking displacement hysteresis loops before strengthening are shown in Figure 40 and after strengthening in Figure 41. Peak loads are summarised in Table 6. From a comparison of the loops in Figure 41 it can be seen that the specimen after strengthening was less stiff due to the prior testing but was otherwise unaffected by the stiffening for the push direction (where the diagonal brace was in tension and the top plate did not separate from the end stud) and the strengthening was effective in the pull direction where the top brace was in compression and the top plate did separate from the end stud at the brace end before strengthening.

The joints separated in a similar fashion to other diagonal brace test specimens as shown in Figure 39.



**Figure 36. Dogleg-braced specimen**



**Figure 37. Top plate lifting in Brace 4 before strengthening**



**Figure 38. Strengthening used in Brace 4**



**Figure 39. Gaps opened at intermediate joints in Brace 4 during testing after strengthening**

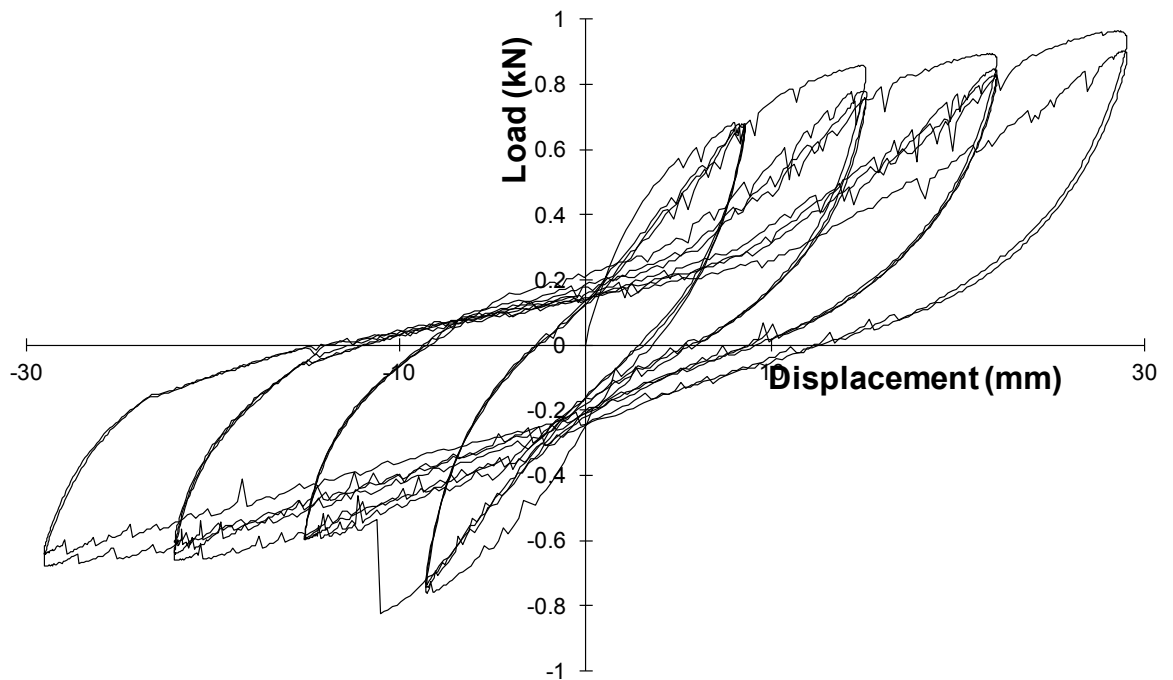

**Figure 40. Hysteresis loops for Brace 4 before strengthening**

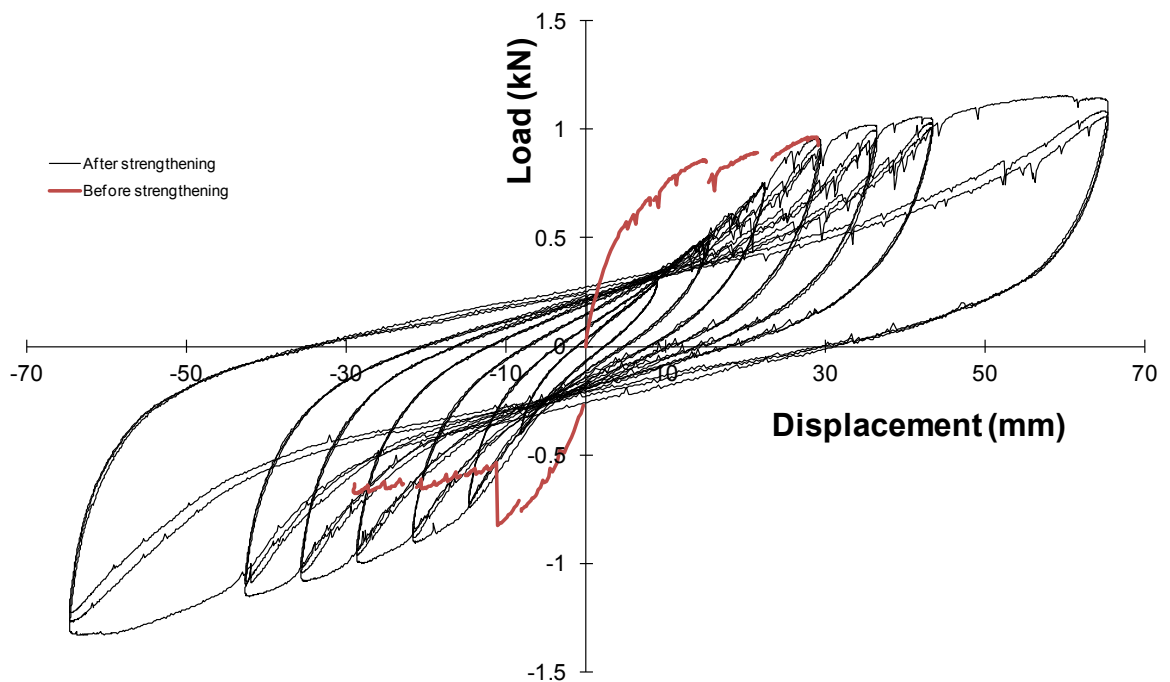

**Figure 41. Hysteresis loops for Brace 4 after strengthening**

**Table 6. Peak loads resisted by the Brace 4 system**

<b>Construction</b>	<b>Push</b>	<b>Pull</b>
Before strengthening	0.96 kN	-0.83 kN
After strengthening	1.15 kN	-1.33 kN

### **3.7 200 x 10 horizontal board (Board 1)**

The 1.2 m long test wall was lined with 200 mm wide boards of 10 mm thick plywood fixed with two 40 x 2.8 mm flat-head galvanised nails to each stud using a 20 mm edge distance as shown in Figure 42, as it is expected to have similar performance to using 10 mm thick solid board and because the 10 mm thick solid board was not readily available. There was an 8 mm gap between boards to ensure there was no friction between adjacent boards, as shown in Figure 43, as shrinkage over time would have taken away any enhancement due to friction. The results are expected to be conservative for 25 mm thick boarding placed wet provided the nail shank diameter has not reduced and the nail penetrates the timber by at least 30 mm.

The hysteresis loops for the horizontal boarded wall are given in Figure 44. The peak resisted push and pull loads for cycles up to  $\pm 36$  mm were 1.58 and -1.54 kN respectively but reached 1.88 and -1.80 kN for cycles up to  $\pm 65$  mm. The boards showed no visible damage during testing except at test completion some nails had pulled out of the framing by up to 1 mm.



**Figure 42. Specimen for horizontal boarded wall**



**Figure 43. Nailing at stud for horizontal boarded wall**

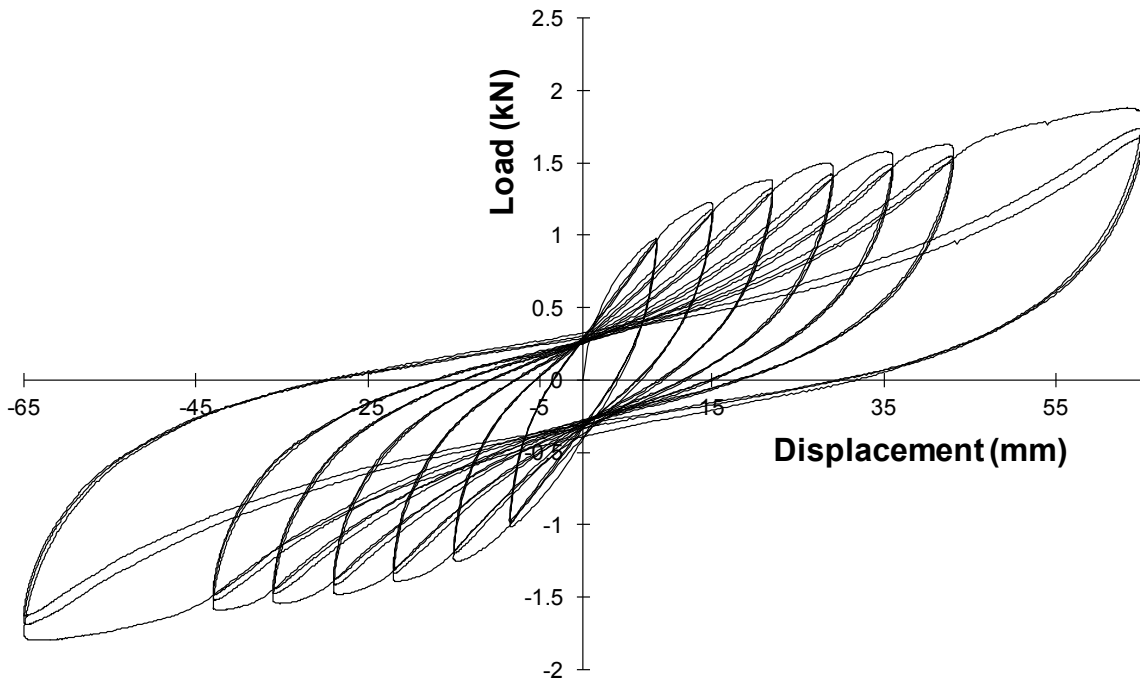

Figure 44. Hysteresis loops for horizontal boarded wall

### 3.8 140 x 20 bevel-back weather board (Board 2)

The 2.4 m long test wall was clad with 140 x 20 mm radiata pine bevel-back weatherboards as shown in Figure 45. Each weatherboard was fixed to each stud with a single 60 x 3.15 mm jolt-head bright nail at 40 mm from the bottom of each weatherboard so that the upper weatherboard encapsulated the top 32 mm of the weatherboard below, but was 8 mm shy of penetrating it. For this particular construction, the resistance was expected to be provided only by the couples between the horizontal lines of nails and the friction of one board against the next. A profile photograph is shown in Figure 46.

The hysteresis loops for the horizontal boarded wall are given in Figure 47. The peak resisted push and pull loads for cycles up to  $\pm 36$  mm were 0.99 and -0.89 kN respectively but reached 1.18 and -1.09 kN for cycles up to  $\pm 65$  mm. The specimen showed no visible damage at test completion.



**Figure 45. Specimen for weatherboard wall Board 2**

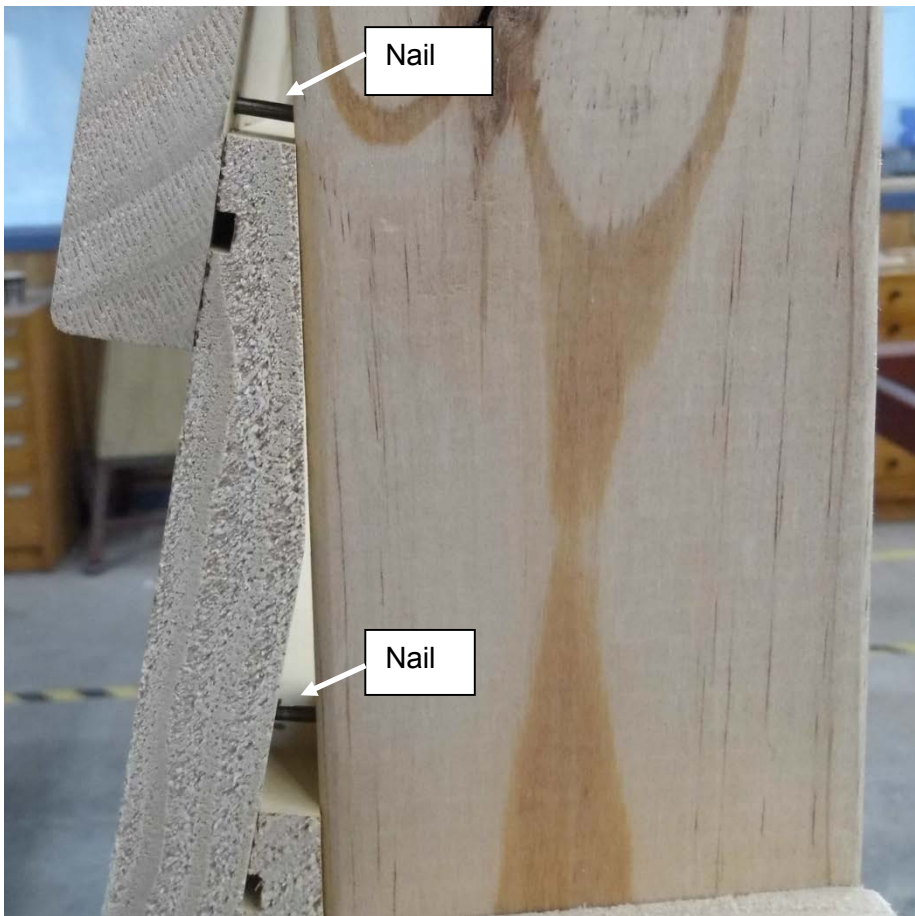

**Figure 46. Nailing of the weatherboards to studs**

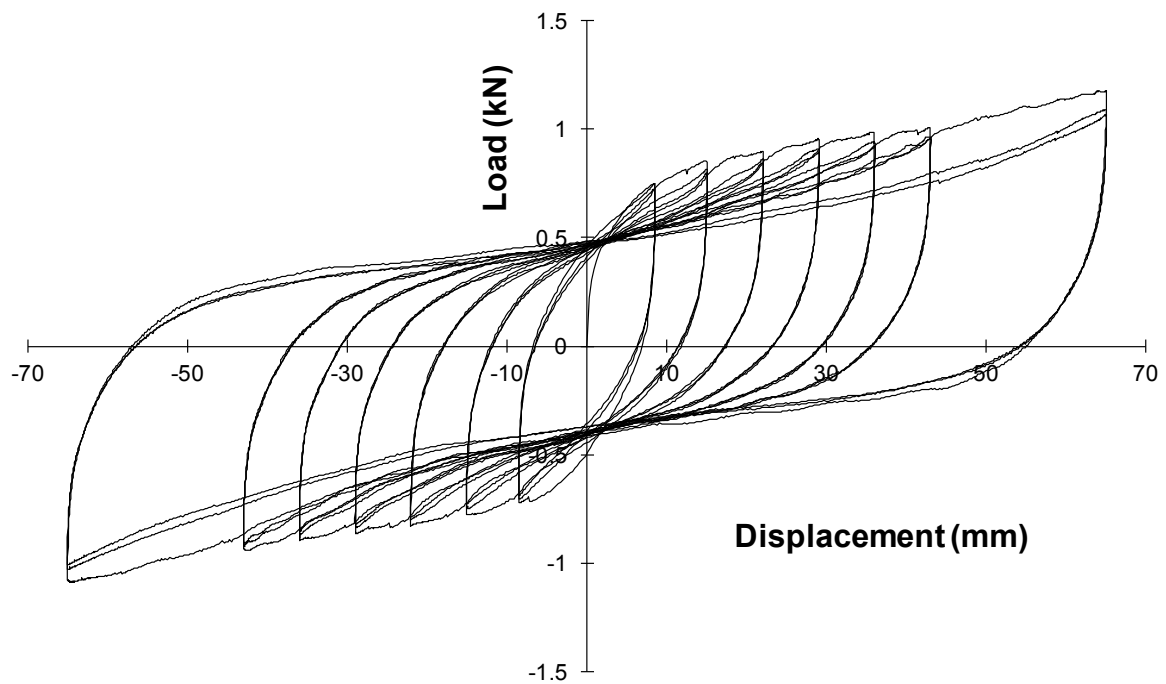

Figure 47. Hysteresis loops for weatherboard wall Board 2

### 3.9 Standard plaster board nominally fixed on one side only (Sheet 1)

The 1.2 m long wall was lined on one side with nominal 10 mm standard plasterboard fixed with 30 x 2.5 flat-head galvanised nails at 300 mm centres around the perimeter of the sheet starting with a single nail in the corner as shown in Figure 48. The nail edge distance was 12 mm.

The hysteresis loops are given in Figure 49. The peak resisted push and pull loads were 1.33 and -1.36 kN respectively. The only damage was at nail locations and the nails progressively sunk into the plasterboard and gouged out a slot in the plasterboard. Eventually the sheet became loose and almost fell from the wall.





Figure 48. Sheet 1 plasterboard single-lined specimen

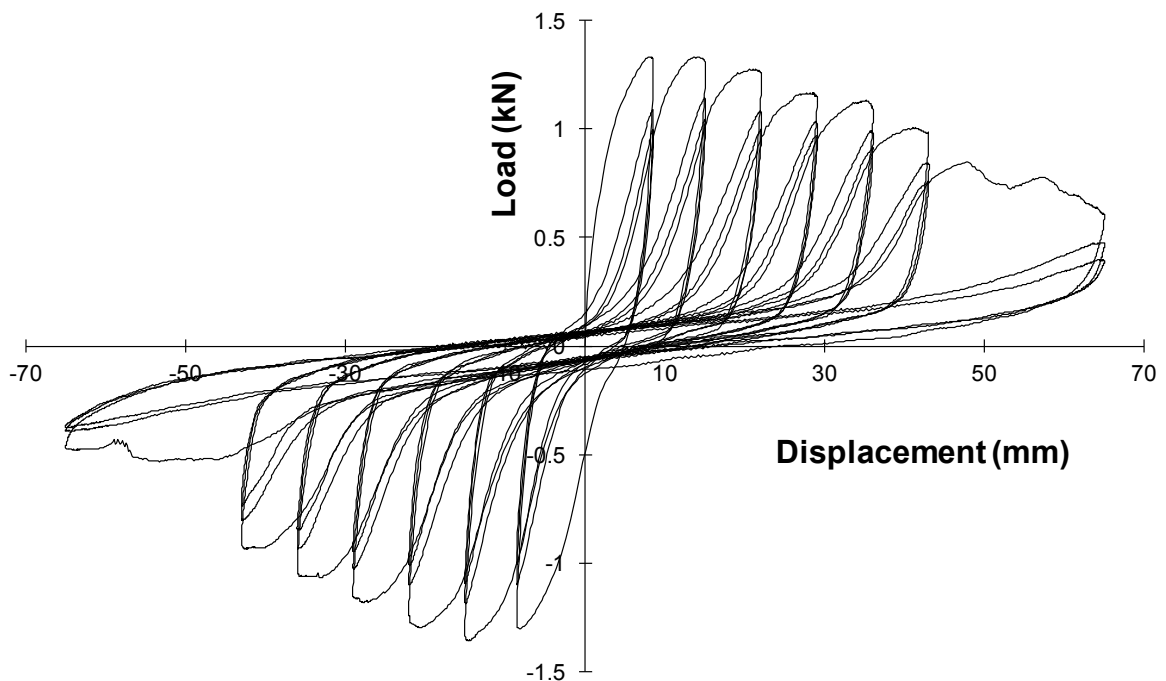

Figure 49. Hysteresis loops for Sheet1 – standard plasterboard one side

### 3.10 Standard plaster board nominally fixed on both sides (Sheet 2)

The 1.2 m long wall was lined on both sides with nominal 10 mm standard plasterboard fixed with 30 x 2.5 flat-head galvanised nails at 300 mm centres around the perimeter of the sheet starting with a single nail in the corner as shown in Figure 50. The nail edge distance was 12 mm.

The hysteresis loops are given in Figure 51. The peak resisted push and pull loads were 3.09 and -3.11 kN respectively. Note, this is an average of 2.3 times the strength of the specimen lined on one side only described in Section 3.9. Figure 51 also shows the force

from twice the backbone of the hysteresis loops of Figure 49 to show that the Sheet 2 specimen (lined on both sides) was in fact more than twice as strong as the Sheet 1 specimen (lined on one side only). It is not clear why the ratio was not closer to two except that the studs on the double-lined system would be less likely to separate from the plates. However, no separation was noted in either test.

The observations were similar to the single-lined system. The only damage was at nail locations and the nails progressively sunk into the plasterboard and gouged out a slot in the plasterboard. Eventually the sheets became loose and almost fell from the wall.



Figure 50. Sheet 2 standard plasterboard lined on both sides of specimen

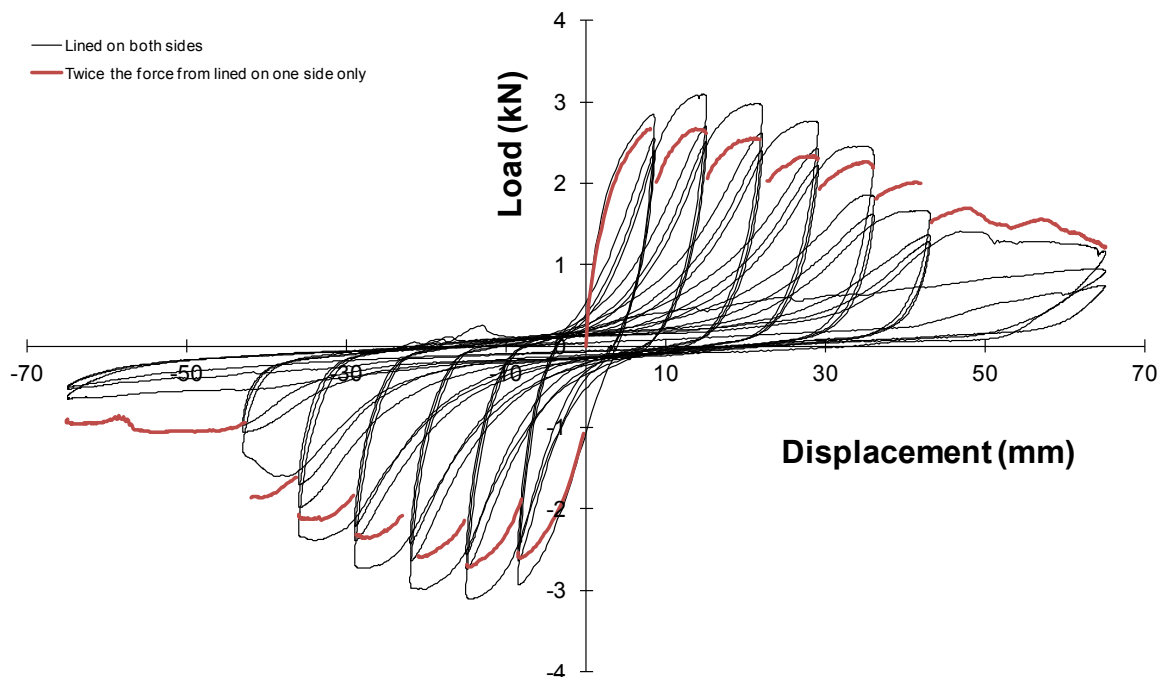

Figure 51. Hysteresis loops for Sheet 2 – standard plasterboard both sides

### 3.11 Tempered hardboard nominally fixed on one side only (Sheet 3)

#### 3.11.1 Panel pin fixings only

The 1.2 m long wall was lined on one side with nominal 3.2 mm thick tempered hardboard fixed with 30 x 1.6 mm zinc-plated panel pins with a 2.3 mm diameter head at 200 mm

centres around the perimeter of the sheet, starting with a single nail in the corner. The nail edge distance was 12 mm. A view of the test wall is shown in Figure 52.

The hysteresis loops are given in Figure 53. The peak resisted push and pull loads were 2.03 and -1.86 kN respectively. The only damage was at nail locations where the nail heads simply pulled through the hardboard. Eventually the sheet became loose and almost fell from the wall.

### **3.11.230 x 2.5 nails with no additional uplift restraints**

The test with the panel pins was stopped, the panel pins removed and the hardboard was re-nailed using 30 x 2.5 mm flat-head galvanised nails at approximately 25 mm from each previous panel pin location, except two nails were used at each corner to replace the single panel pin previously used there. These were placed at 25 mm vertically and horizontally from the corner respectively.

The peak resisted push and pull loads were 3.63 and -3.94 kN respectively. There was no damage at nail locations. The panel was largely undamaged except that the whole panel rocked due to the bottom plate lifting off the foundation beam.

The hysteresis loops are given in Figure 55 which also shows the backbone of the hysteresis loops of Figure 53 to illustrate that this specimen was stronger and more ductile than the specimen with the hardboard fixed using only panel pins.

### **3.11.3 30 x 2.5 nails with additional uplift restraints**

The test with standard uplift restraints (see Section 3.1) was stopped and the panel prevented from lifting by fixing the "P21 end restraints" with an extra 12 power-driven nails and also fixing the bottom plate down with many power-driven nails. No uplift was observed in the subsequent tests.

The hysteresis loops for the panel with these extra hold-downs are given in Figure 57. The peak resisted push and pull loads were now 6.78 and -6.43 kN respectively. The panel bulged out of plane at peak loads but the only damage was at nail locations where the nails heads tore holes in and eventually pulled through the hardboard. At the test completion the sheet became loose and almost fell from the wall.

The plots in Figure 57 also show the backbone of the hysteresis loops of Figure 55 to illustrate that this specimen was stronger but less ductile than the specimen with the hardboard fixed using the same fixing (clouts), but with rocking allowed.



Figure 52. Sheet 3 hardboard single-lined specimen fixed with panel pins

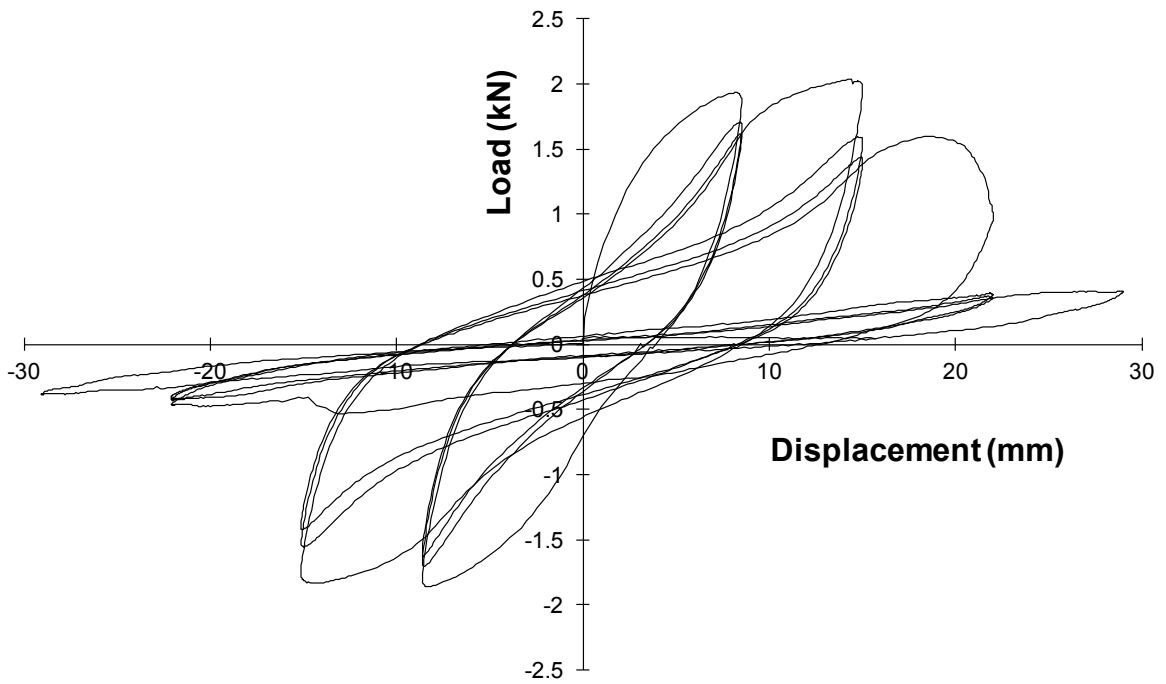

Figure 53. Hysteresis loops for Sheet 3 – tempered hardboard one side fixed with panel pins



Figure 54. Sheet 3 hardboard single-lined specimen fixed with clouts

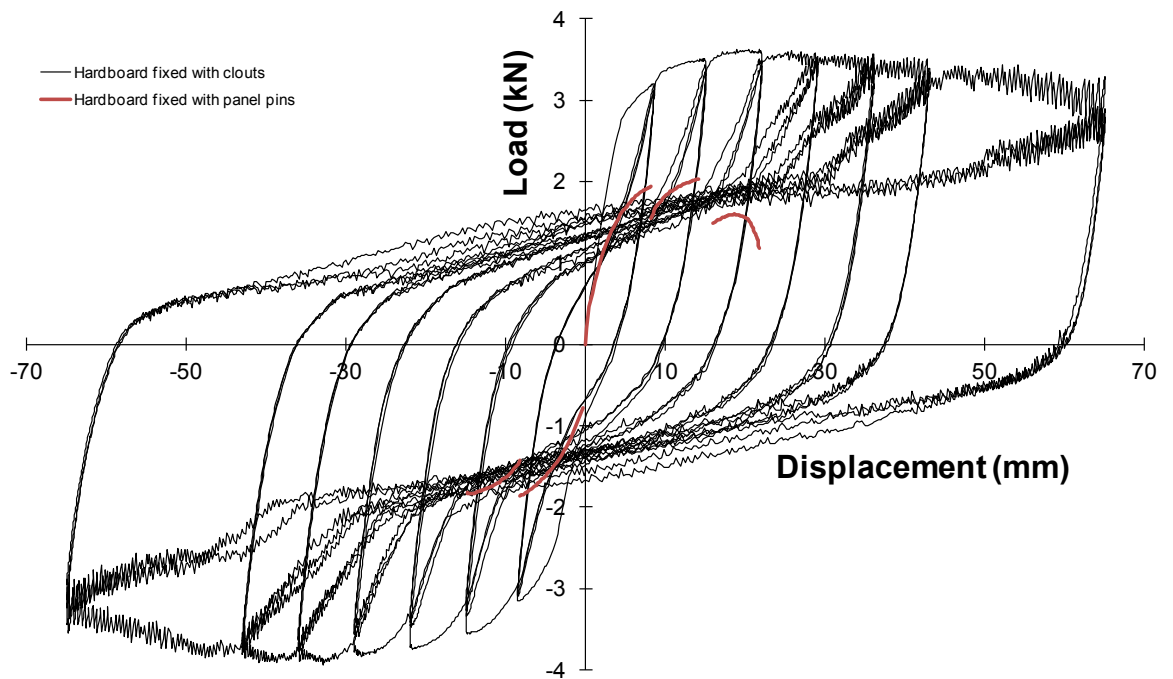

Figure 55. Hysteresis loops for Sheet 3 – tempered hardboard one side fixed with clouts and no extra hold-downs



Figure 56. Sheet 3 bottom plate lifting in hardboard-lined specimen fixed with clouts and no extra hold-down

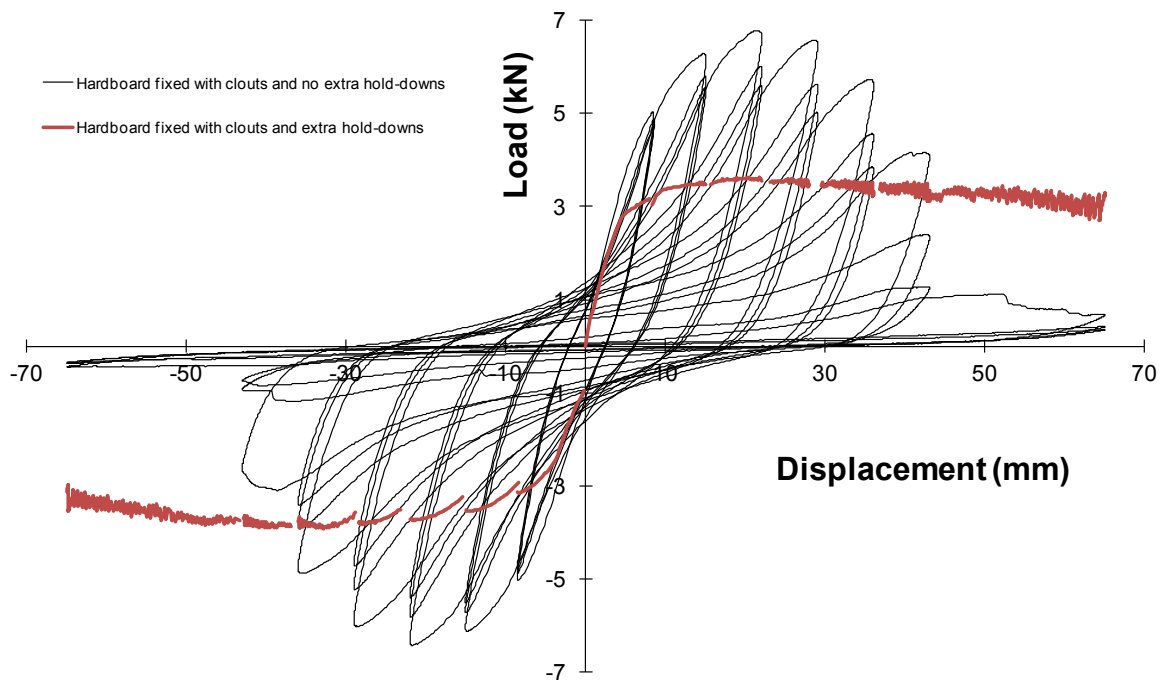

Figure 57. Hysteresis loops for Sheet 3 – tempered hardboard one side fixed with clouts with extra hold-downs

### 3.12 Horizontal corrugated steel (Sheet 4)

The 2.4 m long wall, shown in Figure 58 and Figure 59, was lined on one side with nominal 0.6 mm thick corrugated steel having corrugations at 76 mm centres and of height 17 mm. The corrugated steel sheets had been recovered from 1950s construction

and the metal was low tensile compared to that used in current galvanised steel roofing. The sheets were fixed horizontally with pre-used lead-head nails with 3.5 mm galvanised (somewhat rusty) 60 mm long shanks and lead heads 19 mm diameter at the base and 11 mm high cast over an 8 mm steel flat-nail head. A photograph of the nails is shown in Figure 61.

As shown in Figure 60 the nails were used on every second ridge on each stud except that immediately below a horizontal lap line the sheet was nailed on the third ridge. Sheets overlapped by two ridges and a full trough. The sheets were 860 mm wide and had 11 ridges.

The hysteresis loops are given in Figure 63. The peak resisted push and pull loads were 5.06 and -5.10 kN respectively for displacements up to  $\pm 36$  mm but this increased to 6.06 and -5.95 kN respectively at displacements of  $\pm 65$ .

Adjacent sheets slipped horizontally relative to one another. The only damage was at nail locations and the nail shanks progressively slotted the steel sheet as shown in Figure 62.

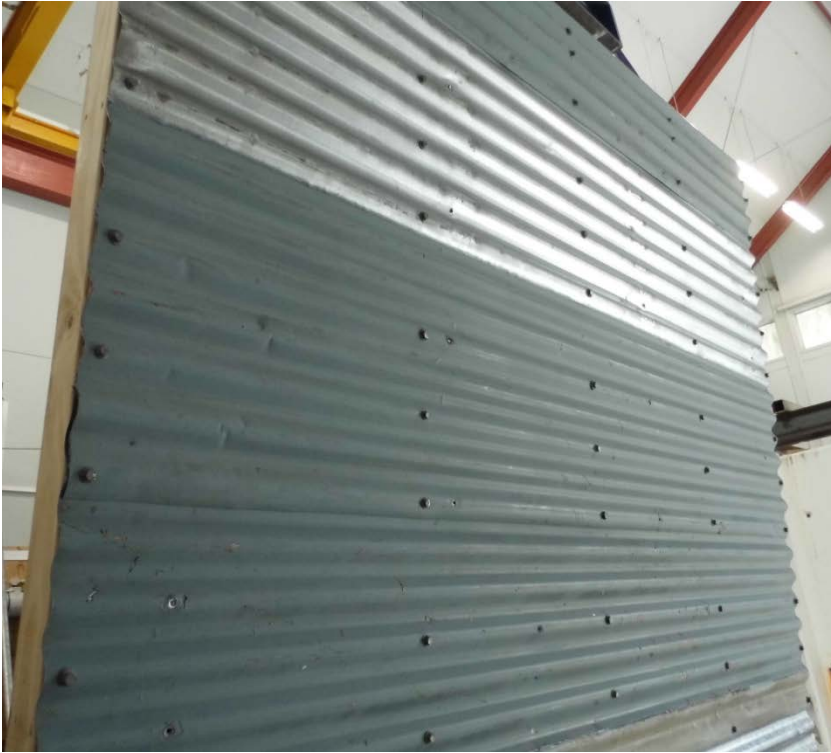

**Figure 58. Front view of Sheet 4 – horizontal corrugated steel**



**Figure 59. Back view of Sheet 4 – horizontal corrugated steel**





**Figure 60. Views of pattern of lead-head nails – horizontal corrugated steel**



**Figure 61. Lead-head nails used for Sheet 4 and Sheet 5**



**Figure 62. Views of sheet slotting at lead-head nails – horizontal corrugated steel**

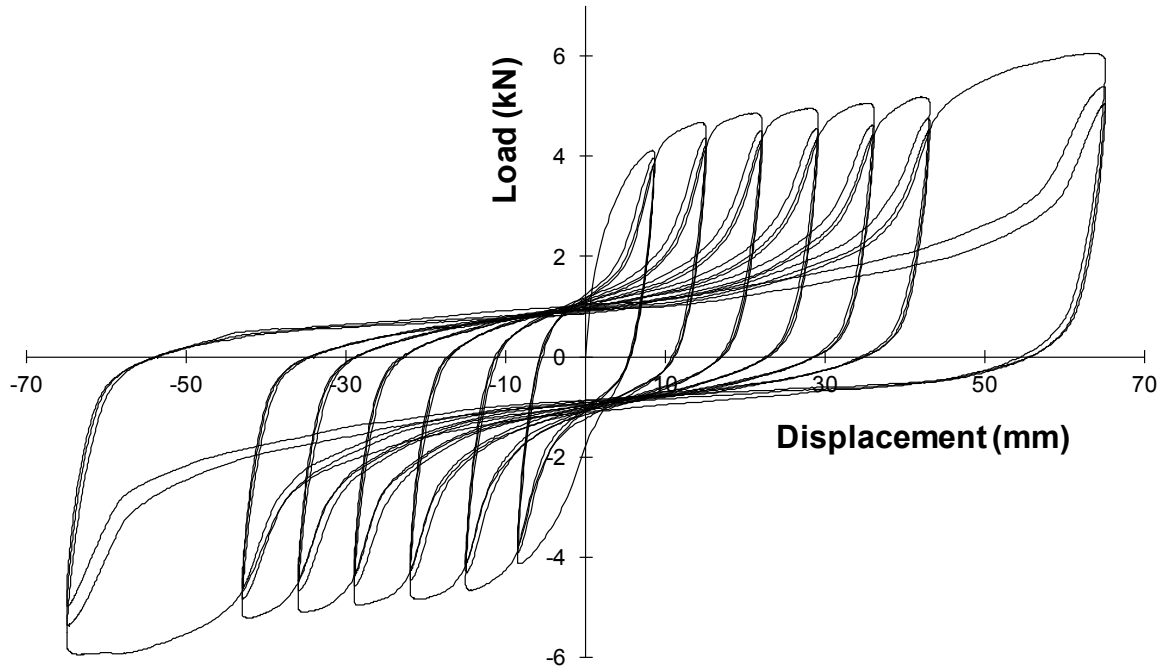

Figure 63. Hysteresis loops for Sheet 4 – horizontal corrugated steel

### 3.13 Vertical corrugated steel (Sheet 5)

This 2.4 m long wall, shown in Figure 64 and Figure 65, was lined in the same manner as Sheet 4 (described in Section 3.12) but the sheets were laid vertically.

Sheets were fixed in horizontal lines along the noggs and the top and bottom plate. As shown in Figure 60 the nails were used on every second ridge horizontally and 800 mm vertically to fix into one of these frame members, except that immediately to the left of a vertical lap line the sheet was nailed on the third ridge. Sheets overlapped by two ridges and a full trough.

The hysteresis loops are given in Figure 68. The peak resisted push and pull loads were 4.20 and -4.19 kN respectively for displacements up to  $\pm 36$  mm but this increased to 4.95 and -4.84 kN respectively at displacements of  $\pm 65$ . Also shown in Figure 68 is the backbone curve of Figure 63. It can be seen that Sheet 4 was approximately 25% stronger than Sheet 5. This may have been because the nails were at 600 mm along the sheets in Sheet 4 but only 800 mm in Sheet 5.

Adjacent sheets slipped vertically relative to one another. The only damage was at nail locations where the nail shanks progressively slotted the steel sheet as shown in Figure 62. The heads of a few lead head nails also popped off.



**Figure 64. Front view of Sheet 5 – vertical corrugated steel**



**Figure 65. Back view of Sheet 5 – vertical corrugated steel**



**Figure 66. Views of pattern of lead-head nails – horizontal corrugated steel**



**Figure 67. Views of sheet slotting at lead-head nails – vertical corrugated steel**

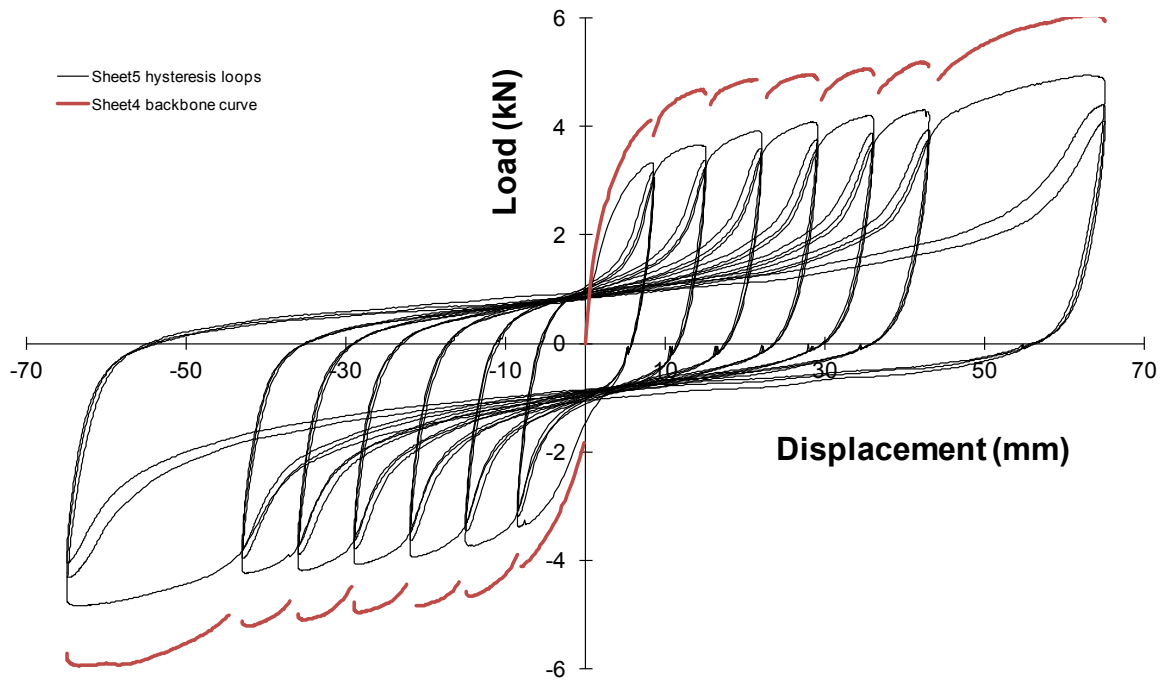

Figure 68. Hysteresis loops for Sheet 5 – vertical corrugated steel

### 3.14 Combo1 – a combination of Sheet 1 and Brace 3

The 2.4 m long wall (see Figure 69) was a combination of Sheet 1 (as described in Section 3.9) and Brace 3 (as described in Section 3.5). It was lined on one side with nominal 10 mm standard plasterboard fixed with 30 x 2.5 flat-head galvanised nails at 300 mm centres around the perimeter of the sheet starting with a single nail in the corner as shown in Figure 48. The nail edge distance was 12 mm. It had a double cross brace fitted between studs as shown in Figure 69.

Early in the test the nails pulled through the plasterboard at the top plate connection near the wall ends, the top plates were lifted by the diagonal braces (Figure 71) and then the braces formed gaps in tension (Figure 72 and Figure 73). Three studs lifted from the bottom plate (Figure 74). Eventually the sheets became loose and almost fell from the wall.

The hysteresis loops are given in Figure 75. The peak resisted push and pull loads were 5.88 and -5.59 kN respectively. Note, this is between the peak loads for the component panels given in Table 7 for Brace 3 with and without strengthening. Thus, the presence of the lining on one side tends to resist the top plate lifting, as would be expected. This information is captured in Figure 76. Here, the backbone curves from the hysteresis loops for the component systems are superimposed on the Combo 1 hysteresis loops. By comparing the curves (5) = (2) + (3) and also (6) = (2) + (4) with the peaks of Combo 1 it can be seen (5) and (6) straddle the peaks of Combo 1.

**Table 7. Peak loads resisted by the component Combo 1 systems**

<b>System</b>	<b>Construction</b>	<b>Push (kN)</b>	<b>Pull (kN)</b>
Sheet 1	–	1.33	-1.36
Brace 3	Before strengthening	2.23	-3.73
	After strengthening	3.65	-4.10
Two x Sheet 1 + Brace 3	Before strengthening	4.89	-6.45
Two x Sheet 1 + Brace 3	After strengthening	6.31	-6.82



**Figure 69. Combo 1 – a combination of Sheet 1 and Brace 3**





Figure 70. Double diagonal brace in Combo 1



Figure 71. Top plate lifting in Combo 1



**Figure 72. Diagonal braces separating in Combo 1**



**Figure 73. Centre joint in diagonal brace separating in Combo 1**



**Figure 74. Middle studs lifting in Combo 1**

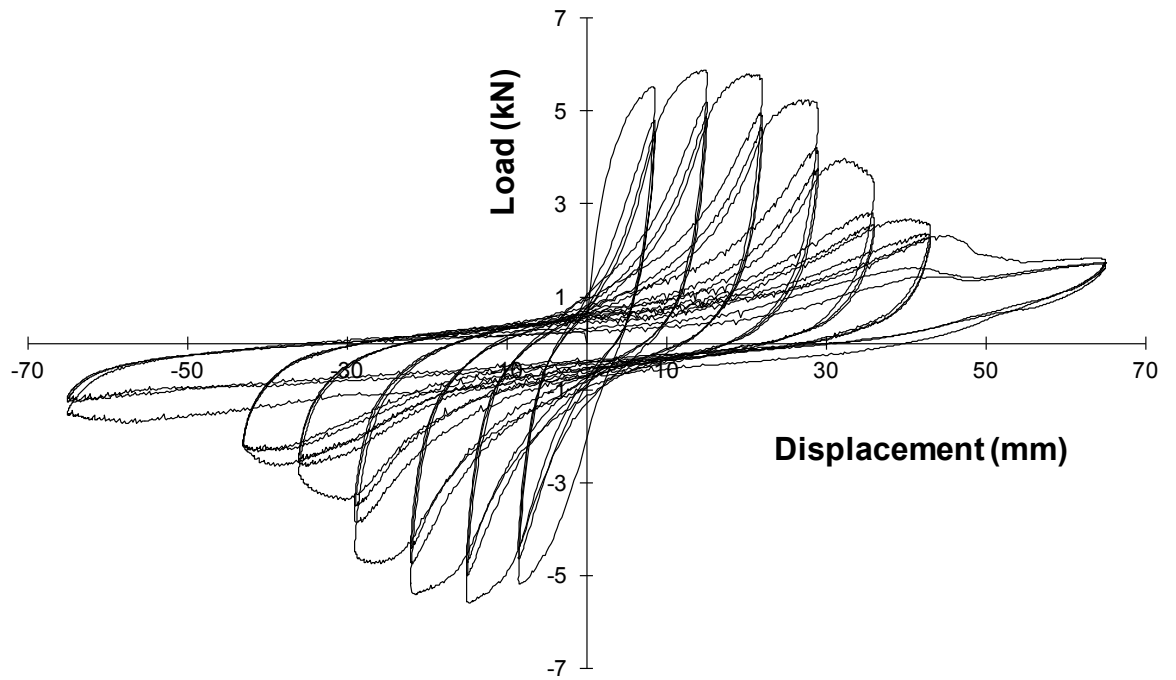

Figure 75. Hysteresis loops for Combo 1 – a combination of Sheet 1 and Brace 3

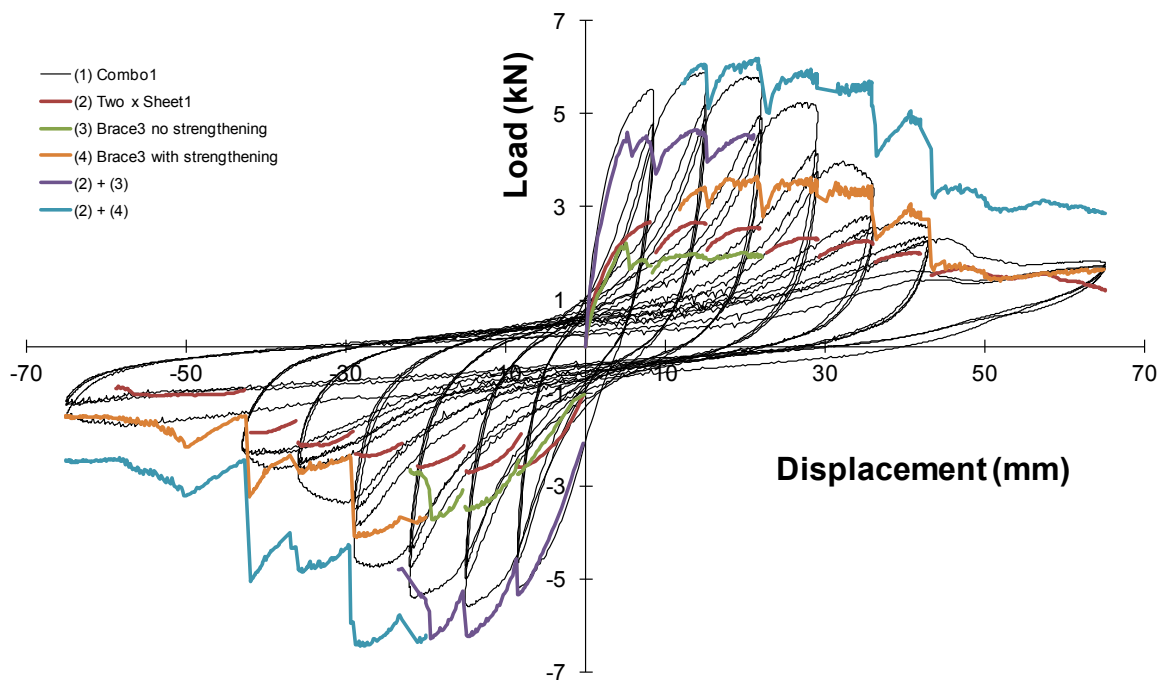

Figure 76. Component hysteresis loops for Combo 1 – a combination of Sheet 1 and Brace 3

## 4. REFERENCES

- Anderson R W, 1981. Investigation of the seismic resistance of interior building partitions. National Science Foundation Contract PFR-8009921.
- Beattie G J, 2006. Repair and reinstatement of earthquake damaged houses – Phase III. BRANZ Study Report No. 158, BRANZ, Wellington
- Buchanan A, Carradine D, Beattie B and Morris H, 2011. Performance of houses during the Christchurch earthquake of 22 February 2011. NZSEE, Vol. 44, No. 4, December 2011.
- Cooney R C, 1979. The structural performance of houses in earthquakes NZSEE, Vol. 12, No. 3, September 1979. NZSEE 2006 Assessment and Improvement of the Structural Performance of Buildings in Earthquakes. Recommendations of a NZSEE Study Group on Earthquake Risk Buildings, June 2006.
- Ireland M, Milburn J and Trowsdale J, 2009. Seismic Retrofit of Government House. 2009 NZSEE Conference.
- Matsumoto N and Fukita F, 2012. A study on wooden lath and plaster wall of Japanese early modern wooden architecture. WCTE conference on timber engineering, July 2012.
- Porter K and Cobeen K, 2009. Loss estimates for large soft story wood-frame buildings in San Francisco. Performance of existing buildings and other structures. ATC & SEI 2009 Conference on improving the seismic performance of existing buildings and other structures 2009.
- NZSEE, 2006. Assessment and improvement of the structural performance of buildings in earthquakes. Recommendations of a NZSEE Study Group on earthquake risk buildings. June 2006. Wellington.
- Pang W, Ziaei E and Filiatralt A, 2012. A 3D model for collapse analysis of soft-story light-frame wood buildings. WCTE conference on timber engineering, July 2012.
- Shelton R H, 1993. Report on racking tests on lath and plaster walls in the Old Government Building, Wellington. BRANZ Test Report for Holmes Consulting Group STR 244 December 1993. Reference to this report is made with the permission of Holmes Consulting.

## APPENDIX APPLICATION OF THIS RESEARCH

The proposed bracing ratings for existing and renovated walls based on the BRANZ testing are given in Table 8. Details of the construction are given in Table 9 (which is a repeat of Table 3).

**Table 8. Summary of proposed bracing ratings**

Label	Bracing System	Strengthening	Peak Push 0 to 36 mm	Peak Pull 0 to -36 mm	Peak Push 0 to 65 mm	Peak Pull 0 to -65 mm	Recommended Bracing rating (BU's)		
							Wind	Earthquake	
Lath1	45 x 6 lath and plaster wall with no horse hair	None	4.8	-4.9	-	-	36	32	Per metre
Brace1	150 x 25 let in brace at 45°	None	2.78	-2.59	2.78	-2.59	48	43	Per brace
		Type1	6.43	-2.58	6.68	-2.58	51	45	Per brace
Brace2	90 x 45 single brace cut between studs	None	-	-	-	-		0	Per brace
		Type1	2.86	-1.04	2.9	-1.04	21	18	Per brace
Brace3	90 x 45 double brace cut between studs	None	2.23	-3.73	2.23	-3.73	44	39	Per brace pair
		Type1	3.65	-4.1	3.65	-4.1	70	62	Per brace pair
Brace4	Dogleg brace	None	0.96	-0.83	0.96	-0.83	16	14	Per brace
		Type1	1.02	-1.08	1.15	-1.33	19	17	Per brace
Board1	200 x 10 horizontal board	None	1.58	-1.54	1.88	-1.8	23	21	Per metre
Board2	140 x 20 bevel back weatherboard	None	0.99	-0.89	1.18	-1.09	7	6	Per metre
Sheet1	Standard plasterboard one side only	None	1.33	-1.36	1.33	-1.36	20	18	Per metre
Sheet2	Standard plasterboard two sides	None	3.09	-3.11	1.33	-1.36	47	41	Per metre
Sheet3	3.2 mm tempered hardboard one side only	None	2.03	-1.86	2.03	-1.86	29	26	Per metre
		Type2	3.63	-3.94	3.63	-3.94	57	50	Per metre
		Type3	6.78	-6.43	6.78	-6.43	99	88	Per metre
Sheet4	Horizontal corrugated steel	None	5.06	-5.1	6.06	-5.95	38	34	Per metre
Sheet5	Vertical corrugated steel	None	4.2	-4.19	4.95	-4.84	31	28	Per metre

**Table 9. Details of construction**

Label	Bracing System	Strengthening	Fixing	Nogs	Fixing Pattern	Wall Length (m)
Lath1	45 x 6 lath and plaster wall with no horse hair	None	TypeE	No	Type 6	2.4
Brace1	150 x 25 let in brace at 45°	None	TypeC	No	Type2	2.4
		Type1				
Brace2	90 x 45 single brace cut between studs	None	TypeD	No	Type3	2.4
		Type1				
Brace3	90 x 45 double brace cut between studs	None	TypeD	No	Type3	2.4
		Type1				
Brace4	Dogleg brace	None	TypeD	@600	Type3	0.6
		Type1				
Board1	200 x 10 horizontal board	None	TypeF	No	Type7	1.2
Board2	140 x 20 bevel back weatherboard	None	TypeG	Yes	Type5	2.4
Sheet1	Standard plasterboard one side only	None	TypeA	Yes	Type1	1.2
Sheet2	Standard plasterboard two sides	None	TypeA	Yes	Type1	1.2
Sheet3	3.2 mm tempered hardboard one side only	None	TypeH	Yes	Type4	1.2
		Type2	TypeA	Yes	Type4	1.2
		Type3	TypeA	Yes	Type4	1.2
Sheet4	Horizontal corrugated steel	None	TypeI	Yes	Type8	2.4
Sheet5	Vertical corrugated steel	None	TypeI	Yes	Type9	2.4

**Legend**

**Fixing**

- (A) 30 x 2.5 galvanised flat-head nails
- (C) 75 x 3.15 galvanised flat-head nails
- (D) 75 x 3.15 bright jolt-head nails
- (E) 25 x 2.5 galvanised flat-head clouts
- (F) 40 x 2.8 galvanised flat-head nails
- (G) 60 x 3.15 bright jolt-head nails
- (H) 30 x 1.6 electroplated panel pins
- (I) Lead heads nails with 60 x 3.5 bright shanks

**Fixing Pattern**

- (1) A nail at each corner and then at 300 mm centres to all studs and plates
- (2) Two nails brace to each stud and three nails brace to each plate
- (3) Two nails each end of braces
- (4) A nail at each corner and then at 200 mm centres to all studs and plates
- (5) Weatherboards fixed to studs with a single nail at 40 mm from the bottom of each weatherboard
- (6) Laths fixed with a single nail
- (7) Two nails at each board/stud intersection
- (8) Nails used at every second ridge to studs below except third ridge one side of lap.
- (9) Nails used at every second ridge to nogs and plates below except third ridge one side of lap.

**Strengthening**

- (1) Strap at brace top between top plate and end stud
- (2) Replace panel pins with 30 x 2.5 nails
- (3) Add 100% rocking restraint

The bracing ratings, BRs, have been assessed from the single test results of each system using the equations  $BR = 0.9 \times \text{effective peak load for wind}$  and  $0.8 \times \text{effective peak load for earthquake}$  (i.e. the first cycle peak load) but with the bracing rating converted to Bracing Units (BUs) where 20 BUs = 1 kN.

The effective peak load is taken as the lesser of:

- (1) Average of the peak push and pull load;
- (2) 1.2 x weakest of push and pull load.

The bracing ratings from the various systems may be added provided it is physically possible to combine them. For example, if a wall is lined and has a diagonal brace then the bracing rating of the wall is the sum of both and if a wall is lined on both sides then the bracing rating is twice the sum of a single side-lined wall.

The bracing rating of the wall must not exceed 60 BUs/m unless the following two criteria are satisfied:

- (1) The design engineer shall ensure that the wall is not able to rock as a solid body when the bracing rating of the wall is applied by taking moments about the pivot point. For typical construction at windows, doorways and corners it may be assumed that there is an uplift resisting force of 3 kN on the uplift end of the wall due to the continuity of construction. This is illustrated in the drawing in Figure 77(a) for a bracing wall rated at B BUs/m of length L, height H, axial load at the centroid W1 and attracted axial load at the tension end W2, with various nailed or other connections between bottom plate and foundation with the  $i^{\text{th}}$  one having a capacity of  $T_i$  and acting at a distance  $X_i$  from the pivot. To ensure there is no rocking:  $BH \leq 3L + W1 \times L/2 + W2 \times L + \sum(T_i \times X_i)$ . If a hold-down bracket (e.g. Gib Handibrac<sup>®</sup>) is used at the wall end studs the connection strength can be taken as the lesser of 15 kN and the design connection strength of the anchor into the foundation. However, if hold-down brackets are used at the end studs then the strength of the nail connections to the foundation should be ignored.
- (2) The design engineer shall ensure that the studs of the wall do not lift off the bottom plate when the bracing rating of the wall is applied by taking moments about the pivot point. For typical construction at windows, doorways and corners it may be assumed that there is an uplift resisting force of 3 kN on the uplift end of the wall due to the continuity of construction. This is illustrated in the Figure 77(b) for a bracing wall rated at B BUs/m of length L, height H, axial load at the centroid W1 and attracted axial load at the tension end W2 with nailed or other connections between bottom plate and stud with the  $i^{\text{th}}$  one having a capacity of  $S_i$  and acting at a distance  $X_i$  from the pivot. To ensure there is no stud separation:  $BH \leq 3L + W1 \times L/2 + W2 \times L + \sum(S_i \times X_i)$ . Note, this formula ignores the restraint imposed on this separation from the fasteners between wall sheathing and bottom plate and this could be included if sufficient information was available. If a hold-down bracket (e.g. Gib Handibrac<sup>®</sup>) is used at the ends the corresponding tension strength between stud and bottom plate can be taken as  $S_i = 15$  kN. If nail straps are used with 30 x 2.5 mm flat-head galvanised nails then each nail can be attributed a strength of 1 kN with a maximum load per strap of 6 kN. However, if hold-down brackets or straps are used at end studs then the strength of the nail connections between studs and bottom plates should be ignored.

The bracing rating of the wall must not exceed 120 BUs/m when founded on timber foundations unless it is established by an engineer that the wall hold-down tension forces can be appropriately transmitted from the base of the wall into the ground.

On no occasion should the bracing rating of the wall exceed 150 BUs/m.

Bracing ratings have not been provided for stucco or fibrous plaster-lined walls as BRANZ was unable to find suitable insitu walls to test. Section 2.2.1 provides some guidance for fibrous plaster walls from other sources.

NZSEE (2006) provided design strengths for lath and plaster walls which (especially for walls lined on both sides) will require careful checks to ensure that a wall does not rock at the design load. The NZSEE recommendation is discussed in Section 2.1.2. This had

some basis in experimental tests discussed in Section 2.1.3 and 2.1.4. Shelton also performed some insitu racking tests on lath and plaster walls from which it was deduced in Section 2.1.5 that the strength for this lining on one side only was 4.3 kN/m (86 BUs/m). Beattie performed some laboratory tests which only achieved 1.11 kN/m (22 BUs/m). However, as with the lath and plaster test described in this report, cement has been added to the plaster to try and simulate the strength enhancement in lime mortar which slowly develops with time. Historically, hair (usually horsehair) was added to the plaster but this was not in the BRANZ tests due to practical difficulties. As noted in Section 2.1.1, the hair helps resist the curls of plaster (keys) connecting the plaster to the laths from falling off. Without these keys the plaster tends to fall off quickly when the wall is racked. Hence the BRANZ test results are expected to be very conservative. On the other hand, the NZSEE (2006) design values appear to be on the high side.

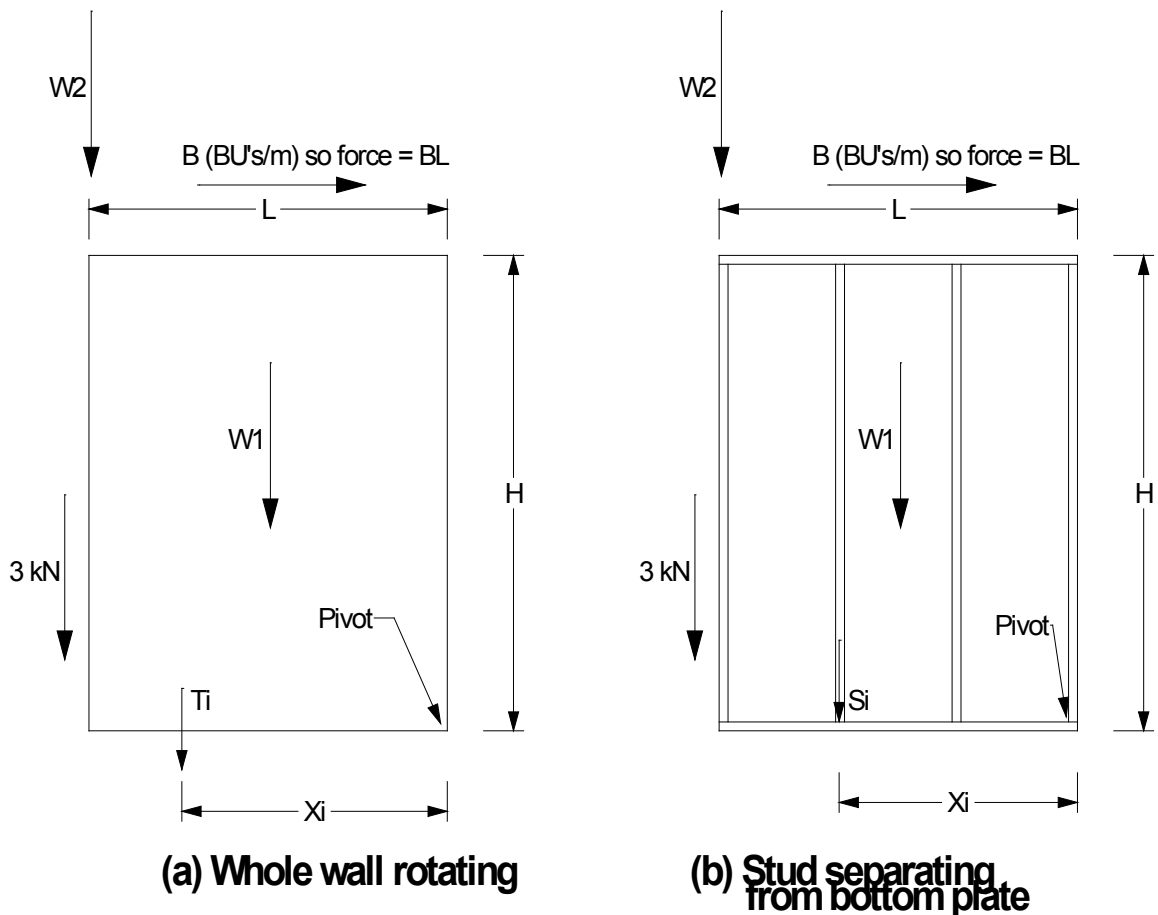

Figure 77. Calculation to ensure wall panel does not rock nor stud separate from bottom plate